

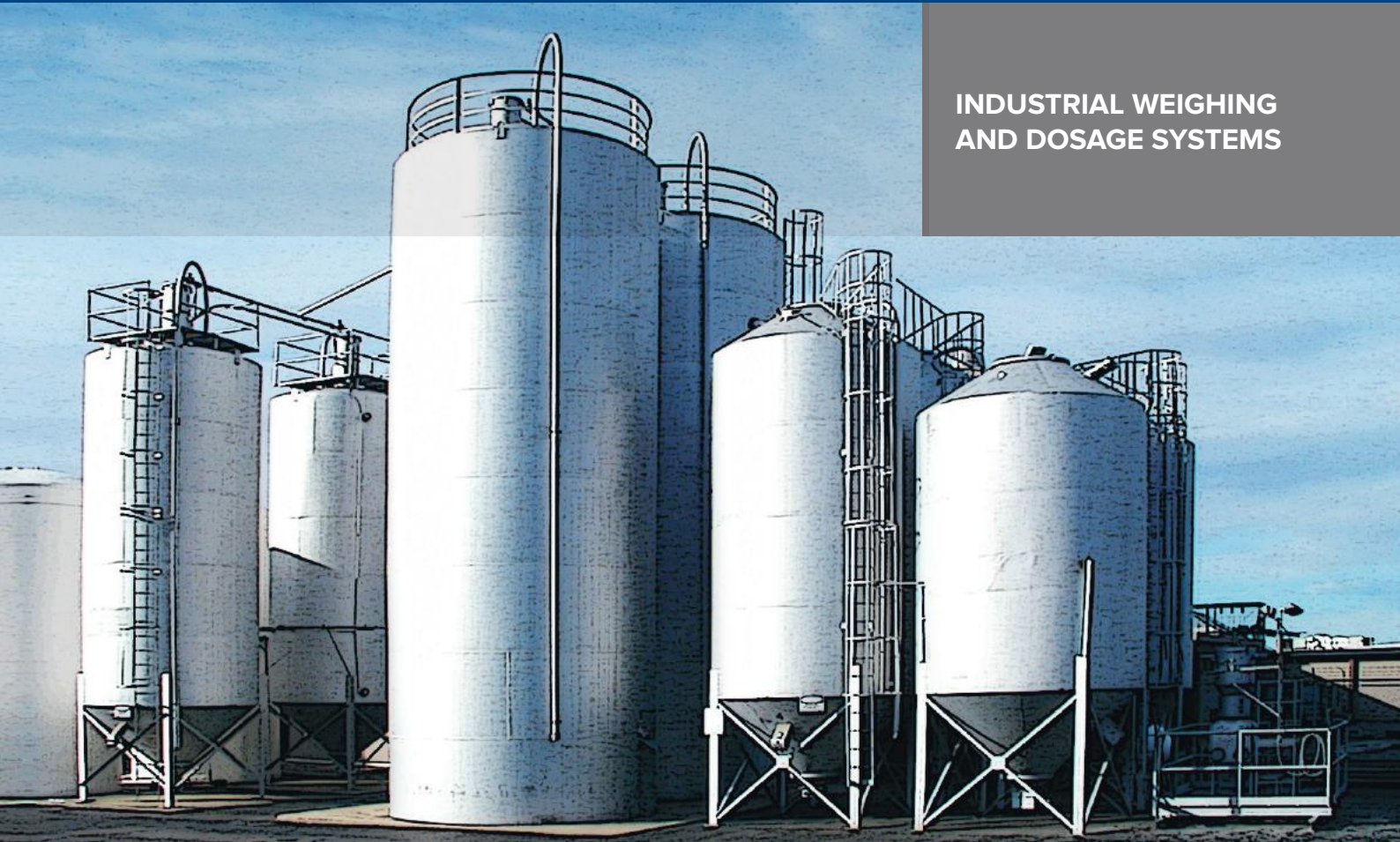



























**INDUSTRIAL WEIGHING
AND DOSAGE SYSTEMS**



CATALOGUE

SUMMARY

	COMPANY PROFILE	2
	PROCESS CONTROL	6
	MAIN TECHNICAL FEATURES	8
	BATCHING AND FILLING	12
	MAIN TECHNICAL FEATURES	14
	SINGLE PRODUCT DOSAGE FOR FILLING	16
	SINGLE PRODUCT DOSAGE FOR DISCHARGING	17
	MULTI-PRODUCT DOSAGE	18
	SINGLE PRODUCT DOSAGE IN FILLING (UP TO 4 SILOS)	19
	SINGLE PRODUCT DOSAGE IN DISCHARGING (UP TO 4 SILOS)	20
	MULTI-PRODUCT SEQUENTIAL DOSAGE	21
	MULTI-PRODUCT SIMULTANEOUS DOSAGE	22
	CONTINUOUS DOSAGE ON BELT	23
	CONTINUOUS DOSAGE IN LOSS-IN-WEIGHT	24
	INTERFACE, EXPANSIONS AND ACCESSORIES	26
	SOFTWARE	29
	DINITOOLS, WEIMONITOR	29
	LOAD CELLS	30
	SHEAR BEAM	32
	COMPRESSION	34
	DOUBLE SHEAR BEAM	36
	BENDING BEAM	38
	ALUMINIUM SINGLE POINT	40
	STAINLESS STEEL SINGLE POINT	42
	TENSION	44
	APPLICATION TIPS	46
	JUNCTION BOXES	47



production
design
quality control

Scales and weighing systems



Dini Argeo, a company which has been producing scales and weighing systems since 1846, has been registered since 02/04/1906 at the Registry of Metric Manufacturers provided by the Royal Decree nr. 226 of 12/06/1902.



Dini Argeo is a company specialising in the design and manufacturing of scales and weighing systems worldwide-known for quality and reliability.

The solutions created by **Dini Argeo** are suitable for any industrial weighing application:

- reading, collection, processing and transfer of weight data
- simple, sequential, simultaneous dosage, in-loading or unloading, single or multicomponent dosage, continuous dosage on belt conveyors or loss-in-weight feeding.
- Weighing in areas endangered by potentially explosive atmospheres (ATEX)
- piece counting, labelling
- control of production lines, statistical check of prepackaged products
- logistics weighing (pallet scales, pallet truck scales, weighing forks for lift trucks, crane scales)
- vehicle weighing (weighbridges, wheel weighers, static and dynamic axle weighers).

A full range of interfaces and communication protocols is available as standard thus making Dini Argeo products easily integrable into industrial automation and processing for the development of OEM systems with customisable functions.



Dini Argeo has obtained the Quality Management System certification according to the UNI EN ISO 9001: 2008 for the design, manufacture and after sales service in respect of measuring instruments, scales and weighing systems, components and software.



The instruments produced by Dini Argeo are approved for legal-for-trade application according to the European standard EN 45501 - Directive 2009/23/EEC. The CE-M mark certifies that the instrument is supplied with the CERTIFICATE OF EC TYPE-APPROVAL issued by the Central Metric Office validating the suitability for legal-for-trade use.



Dini Argeo is a certified company pursuant to ATEX Directive 94/9/EC (Annex IV) and therefore authorised to produce and market equipment marked by Ex-symbol intended for use in potentially explosive atmospheres.



Dini Argeo Group

A COMPREHENSIVE SERVICE

Dini Argeo offers the customer a complete service ranging from the working out of customised solutions and supply of weighing components to the development of software for PC and communication networks, calibration and approval services of OEM systems. Dini Argeo has grown into a group with a strong international calling, composed of subsidiaries in Europe and Asia, alongside a distribution and customer service network in more than 70 countries around the world. Dini Argeo works in cooperation with the other companies of the Group, which are market leaders in their specific field of activity:

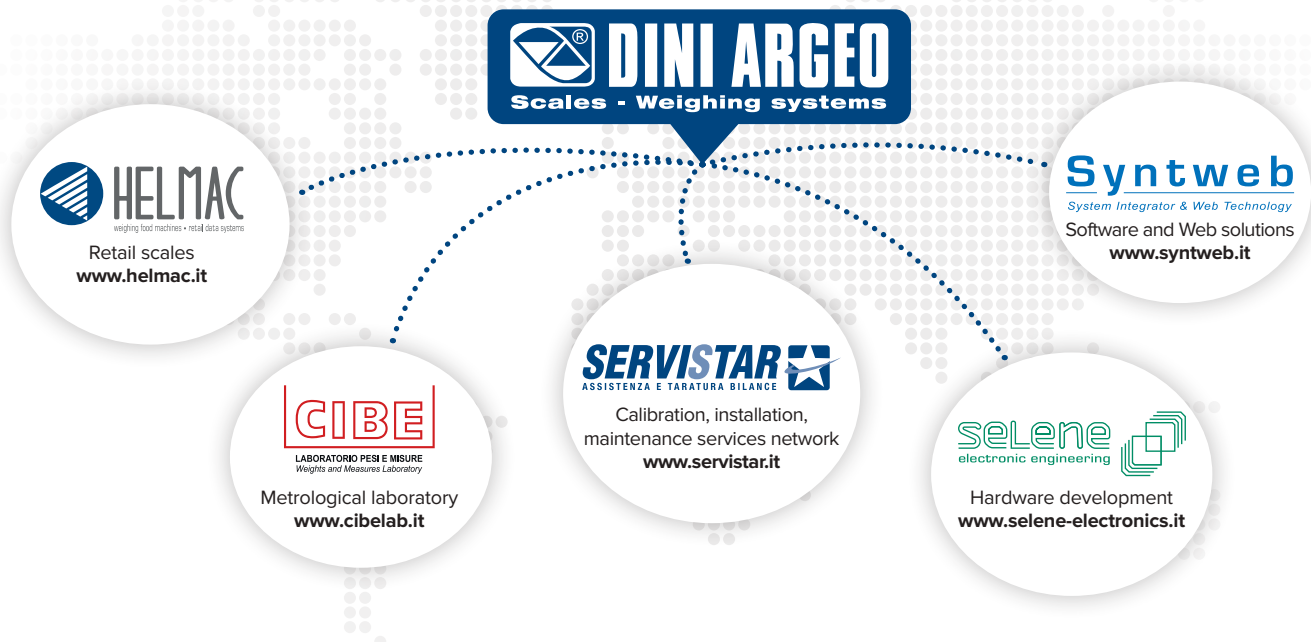

Dini Argeo manufactures non-automatic weighing instruments in conformity with the 2009/23/EEC Directive. The DG0126 mark states the instrument is subject to the EC verification by the manufacturer according to the Certificate of EC approval of the Production Quality Assurance System.

Dini Argeo produces instruments in compliance with the requirements laid down by the recommendations of the International Organization of Legal Metrology (OIML):

- Load cells approved to OIML R60
- Non-automatic weighing instruments approved to OIML R76
- OIML R134 approved dynamic weighers for vehicle transiting at a low speed.
- OIML R51 approved “start/stop” automatic catchweigher on belt conveyors.
- Gravimetric filling instruments approved to OIML R61.

Dini Argeo obtained the GOST-R certification ensuring that its instruments comply with the regulations provided for by the Russian Federation.

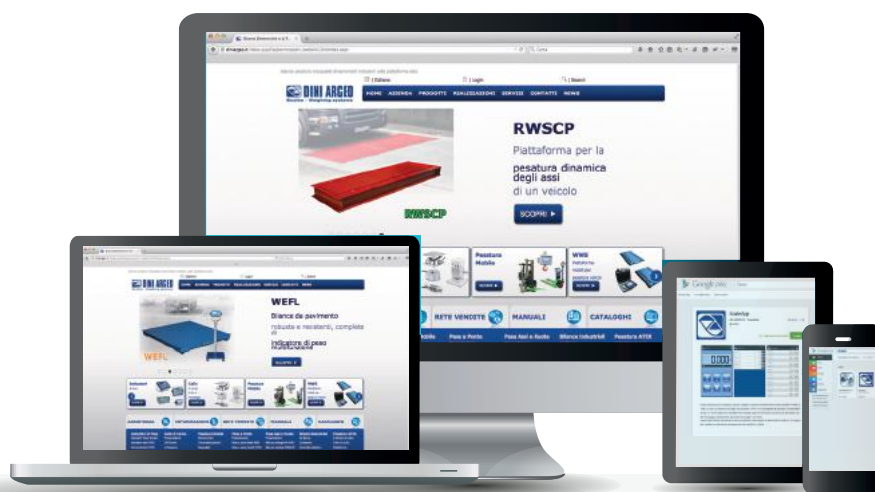

Visit our website www.diniargeo.com

for full product, technical information and advice for your weighing applications.



Enter
THE INFORMATION area
and send the request form
directly from the site.



Download
Dini Argeo weighing apps
free of charge
from **Google play**.

SYMBOLS LEGEND



The products bearing this mark can be used in potentially explosive environments 1 and 21 or 2 and 22, classified by the **ATEX** directives.



The products bearing this mark are usually constructed in **STAINLESS STEEL** for use in environments with very strict hygiene requirements or for providing greater protection from all types of corrosion.



The IP classification indicates the protection degrees which the instrument may have in relation to penetration of solid bodies (1st digit) and/or liquids (2nd digit). Many of Dini Argeo weighing systems ensure total protection from dust, humidity, and water sprays (IP65 and IP67 protection), up to hermetic sealing in submersion (IP68 protection).



These symbols represent, in a simplified way, the typical use of the load cell. In particular, they indicate:

1. suspended hoppers / tanks
2. silo of any size
3. horizontal tanks, whether or not containing liquids
4. 4-cell platforms
5. single-cell platform.

The complete range OF DINI ARGEO PRODUCTS



WEIGHT INDICATORS

Weight indicators, repeaters, and transmitters for easy or advanced industrial applications of: totalization, parts counting, statistical checking, industrial price computing, weigh bridges or wheel and axle weighing systems management, single or multi product dosages in filling and discharging, etc.



LOAD CELLS

Off center, bending beam, shear beam, double shear beam, compression, tension, column load cells, junction boxes, and kits for creating small, medium, large-capacity weighing systems.

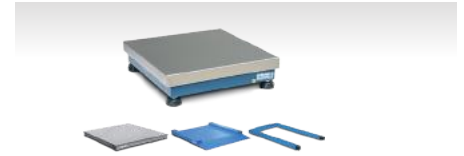

WEIGHING MODULES

Single or 4-cell platforms, pallet-weighers, levers platforms for weighing of metal profiles, rods or pipes, overhead monorail and wall quarter weighing modules.



MOBILE WEIGHING

Pallet truck scales, crane scales, weighing kit for forklift trucks, pallet weighing which allow to integrate the weighing in the logistics warehousing, the materials handling and the lifting of suspended loads.

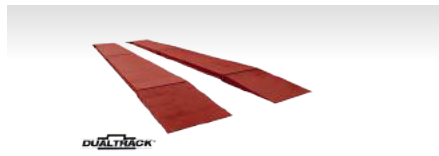

WEIGH BRIDGES

Classic and dual track weigh bridges for fixed or mobile installations, particularly suitable in industrial, agricultural, and commercial fields, and platforms for the axle dynamic weighing of a vehicle in transit.



WHEEL AND AXLE WEIGHING PLATFORMS

Analog or wireless platforms suitable for creating vehicle weighing mobile stations, directly where one needs, on any type of flat surface, by saving time and money.



INDUSTRIAL SCALES

Multifunction, flexible, precision scales for counter-top and floor, and high versatility modular weighing systems. Suitable for industrial, commercial, and laboratory use.



LABORATORY SCALES

"Scale House" is a brand that distinguishes products for industry, laboratory, retail as well as weighing in general, carefully selected in order to have the best quality/price ratio.



WEIGHTS, SETS OF WEIGHTS, MASS SAMPLES, AND CALIBRATION SERVICES

Cibe Metrological Laboratory offers a wide range of weights, sets of weights, mass samples, and accessories as well as calibration services and Periodic Verification of automatic and non automatic weighing instruments.



SCALES, CASH POINTS AND AUTOMATIC MACHINES FOR RETAIL

Helmac designs and manufactures price computing, bench, and hanging scales, for use in shop, supermarket, and mobile sales, POS systems, cash registers and price computing automatic machines for agro-food industries.



WEIGHING SOFTWARE

Syntweb offers software solutions connected to the weighing world, including programs for: reading, checking and recording of weighs; manual of automatic dosage; vehicle IN/OUT weighing with weighbridge; management of the production cycle, disposal and traceability of waste; pieces counting; statistical check of the filling processes; etc.

EASY-TO-USE INDICATOR, TRANSMITTER FOR WEIGHING AND AUTOMATION

PROCESS CONTROL



INDUSTRY



LOGISTICS



BUILDING



BOATYARD

WOOD
INDUSTRY

FUELS

The weight indicators of the PROCESS CONTROL range are the most economical and practical solution to read the weight of the load cells and transmit it to external devices (PCs, PLCs, microcontrollers etc), via RS232, RS485 serial port, relay output or programmable analog output.

Thanks to the plug and play external switching, the user can communicate in Ethernet, WIFI, PROFIBUS and RADIO FREQUENCY.

Each instrument is designed to be installed on a DIN rail, or panels with standard fixings, easily adaptable with existing installations. The multifunction software will allow you to convert the weight into other units of measurement (Newton, litres, pieces...), measure the peak weight, perform consecutive accumulation, and transmit the total.

The design of the hardware and the operating software is carried out in Italy by a technical staff who provide the knowledge for the production of OEM systems, with customised protocols and features. All indicators are approved for legal for trade use, according to EN45501, OIML R76.



OIML R76 (EN45501)
OIML R61 - MID



THE RANGE



DGT1S

Weight transmitter in a slim case, 1 weighing channel and "quick connect" system



DGT1

Weight transmitter in a compact case, 1 weighing channel



DGT4

Weight transmitter with 4 weighing channels



DGTQ

Weight transmitter for panel mounting, with 4 weighing channels



CLEAR EASY-TO-READ VIEW

The LED display allows for quick and easy check of the weight status of any load applied to the load cells. It also greatly simplifies the implementation of any changes to the configuration.



STANDARD DIN SIZES

The DGTQ and DGTP series indicators have standard DIN sizes.



SIMPLIFIED WATERPROOF KEYBOARD

The simplified keyboard ensures simplicity and immediacy of use. The DGT PK series provides a numeric/functional keypad, ideal for handheld applications.



QUICKLY CONFIGURATION FROM PC WITH DINITOOLS

The Dinitools software for PC, supplied as standard, helps to quickly program and calibrate the indicator and create a database of the installations. These functions help to quickly replicate the installed systems, saving time when installing new equipment.



DGTP

Weight transmitter for panel mounting with 4 weighing channels and 20mm display



DGT20

Weight indicator for table/panel/wall mounting, with 4 weighing channels



DGTPK

Weight indicator for table/panel/wall mounting, with 4 weighing channels and extended keyboard



DGT100

Weight indicator / Weight repeater with 100mm maxi display.

MAIN TECHNICAL FEATURES

For DIN BAR installation



Visit www.diniargeo.com web site for more information.

- As standard
- As option (>> page 26)
- Not available for this model

	DGT1S	DGT1SAN	DGT1	DGT1AN	DGT110	DGT4	DGT4AN	DGT4PB
COMMUNICATION INTERFACES	Profibus DP (>> page 26)	○	○	○	○	○	○	●
	Ethernet TCP/IP (>> page 26)	○	○	○	○	○	○	-
	Modbus TCP / DeviceNET / CanOpen / EtherCat / ProfiNet	○	○	○	○	○	○	-
	Modbus RTU protocol	●	●	●	●	●	●	●
	RS485 serial port	1	1	1	1	1	1	-
	RS232 serial port	1	1	1	1	1	1	1
	USB connection for PC programming with Dinitools software	○	○	○	○	○	○	○
	Alibi memory	○	○	○	○	○	○	○
	Bluetooth	○	○	○	○	○	○	○
868MHz Radio frequency module	○	○	○	○	○	○	○	
IN/OUT	Electronic outputs	2	2	-	-	2	2	2
	Digital inputs	2	2	-	-	2	2	2
	Analog output (0...5 Vdc, 0...10 Vdc, 0...20 mA, 4...20 mA)	-	●	-	●	-	-	●
HARDWARE	Dimensions (mm) (lxhxw - Large x high x width)	22,5 x 111 x 120		53 x 90 x 58		106 x 90 x 58		
	Red LED display	8 mm		8 mm		13 mm		
	"Quick Connect" system (>> pag. 28)	●		-		-		
	Keyboard	Waterproof mechanic						
	case	ABS						
	Power supply	12/24 Vdc, 5 W						
	Operating Temperature Range: Internal use / CE-M / Humidity	-20...+60°C / -10...+40°C / 85%						
	IP protection	-						
WEIGHING	Connectable load cells	up to 16 of 350Ω						
	Conversions / Resolution / F.S. max of Display Screen	3200 Hz / 24 bit / ± 999999						
	Converter / Number of scale inputs	24 bit / 4 channels						
	Theoretical calibration (mV/V)	●						
	Multifunctional firmware	●						
	OIML features	3000e, 2x3000e, 6000e, 2x6000e, 10000e						
	OIML certifications	OIML R76 - R61 (MID)						

(1) with option (>> page 26)

For **PANEL** mounting

For **BENCH/PANEL/WALL** mounting

For a **WALL** mounting



For PANEL mounting						For BENCH/PANEL/WALL mounting						For a WALL mounting		
DGTQ	DGTQAN	DGTQPB	DGTP	DGTPAN	DGTPPB	DGT20	DGT20AN	DGT20PB	DGTPK	DGTPKAN	DGTPKPB	DGT100	DGT100AN	DGT100PB
○	○	●	○	○	●	○	○	●	○	○	●	○	○	●
○	○	-	○	○	-	○	○	-	○	○	-	○	○	-
○	○	○	○	○	-	○	○	-	○	○	-	○	○	-
●	●	●	●	●	●	●	●	●	●	●	●	●	●	●
1	1	-	1	1	-	1	1	-	1	1	-	1	1	-
1	1	1	1	1	1	1	1	1	1	1	1	1	1	1
○	○	○	○	○	○	○	○	○	○	○	○	○	○	○
○	○	○	○	○	○	○	○	○	○	○	○	○	○	○
○	○	○	○	○	○	○	○	○	○	○	○	○	○	○
○	○	○	○	○	○	○	○	○	○	○	○	○	○	○
2 + 6 ⁽¹⁾	2 + 6 ⁽¹⁾	2 + 6 ⁽¹⁾	6	6	6	2	2	2	6	6	6	2	2	2
2	2	2	4	4	4	2	2	2	4	4	4	2	2	2
-	●	-	-	●	-	-	●	-	-	●	-	-	●	-
96 x 96 x 80			144 x 72 x 129			214 x 157 x 150			214 x 196 x 150			433 x 205 x 202		
13 mm			20 mm			20 mm			20 mm			100 mm		
-			-			-			-			-		
Waterproof mechanic						Waterproof mechanic						Waterproof mechanic		
ABS						Aluminium / Painted steel						Stainless Steel		
12/24 Vdc, 5 W						12/24 Vdc, 5 W						12/24 Vdc, 5 W		
-20...+60°C / -10...+40°C / 85%						-20...+60°C / -10...+40°C / 85%						-20...+60°C / -10...+40°C / 85%		
IP40						IP40						IP68		
up to 16 of 350Ω						up to 16 of 350Ω						up to 16 of 350Ω		
3200 Hz / 24 bit / ± 999999						3200 Hz / 24 bit / ± 999999						3200 Hz / 24 bit / ± 999999		
24 bit / 4 channels						24 bit / 4 channels						24 bit / 4 channels		
●						●						●		
●						●						●		
3000e, 2x3000e, 6000e, 2x6000e, 10000e						3000e, 2x3000e, 6000e, 2x6000e, 10000e						3000e, 2x3000e, 6000e, 2x6000e, 10000e		
OIML R76 - R61 (MID)						OIML R76 - R61 (MID)						OIML R76 - R61 (MID)		

DESIGNED FOR THE INDUSTRIAL AUTOMATION AND THE PROCESS

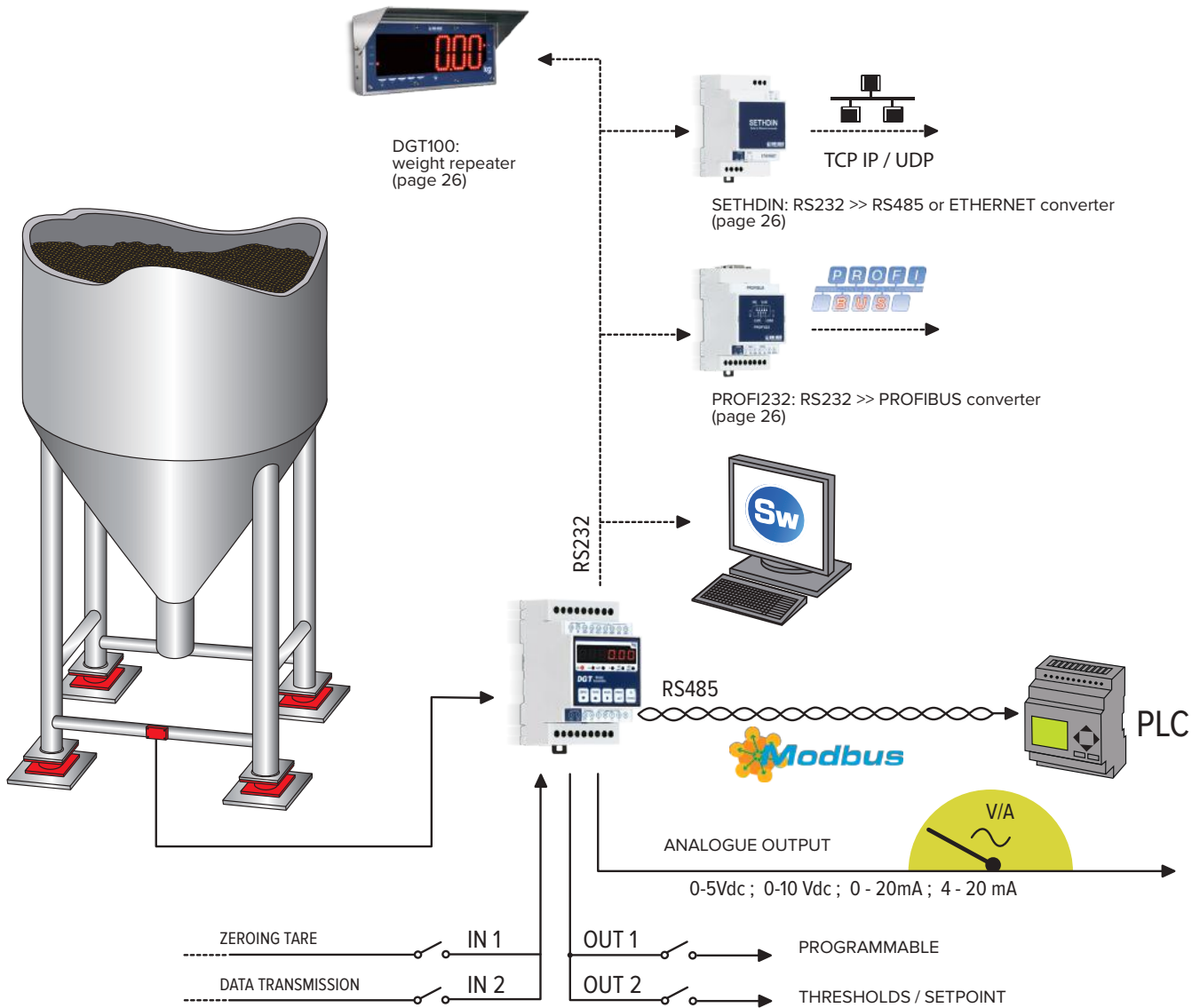

Example of system with DGT 1

FUNCTIONS OF THE STANDARD PROGRAM

- Digital or theoretical calibration and configuration from indicator keyboard or PC via Dinitools, with the functionality of storing the setup of the instrument to backup, simplify the technical assistance, or replicate the same configuration on other instruments (OEM).
- Programmable signal linearization of up to 8 points.
- Quick recalibration of the zero point.
- Control of the overload and underload status of the load cells.
- Keyboard locking functions and limited menu access through programmable password.
- Fast and accurate weight reading with adjustable speed of up to 3200Hz.
- Modbus RTU protocol, as standard fitted
- Dini Argeo protocol for creating control programs on a PC that can read the weight, read the digital inputs, drive the relay outputs.
- Event log
- Possibility to create customized software according to the needs (OEM).
- Quick interface with ETHERNET, PROFIBUS, WIFI, USB module, IN / OUT expansion.



DGT-Q
Weight
Transmitter

INDICATORS FOR FILLING, DOSAGE AND PROCESS

BATCHING AND FILLING

The indicators for dosage of the BATCHING line offer state of the art technology for weighing and dosing, at a very competitive price. All the indicators are fully designed and manufactured in Italy and offer great performance and versatility. The multifunction dosage software is fully configurable and adaptable to any application, thanks to a rich and full programming menu and to the internal development area for the implementation of fully customized programs.

The range of Touch Screen indicators offers the possibility to create customized display interfaces, in order to simplify the user operations and reducing mistakes.

All instruments are fitted with programmable databases and different accumulator totals (daily, weekly, monthly, annual, per formula, per ingredient).

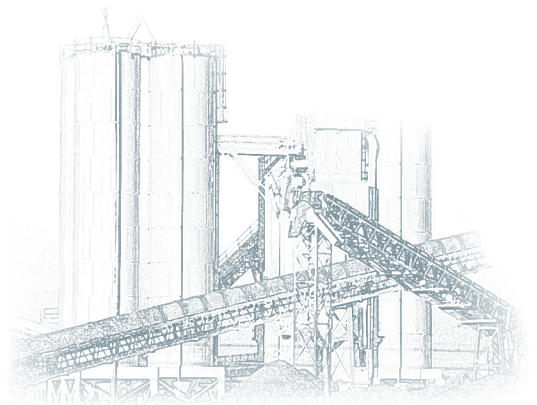

OIML R76 (EN45501)
OIML R51 - MID
OIML R61 - MID
OIML R134

Three different dosage modes are available on the same product



SINGLE COMPONENT
DOSAGE FOR FILLING



SINGLE COMPONENT
DOSAGE FOR DISCHARGING



MULTI COMPONENT
DOSAGE

THE RANGE



DGTQF

Indicator for dosage systems,
for panel mounting



DGTP

Indicator for dosage systems, for panel
mounting, with 20mm display



DGTPK

Indicator for dosage systems
with extended keyboard

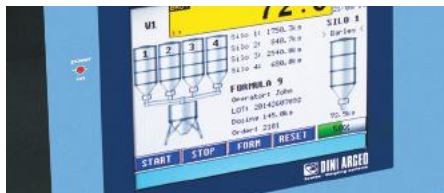

CUSTOMIZABLE DISPLAY SCREEN

The backlit graphic LCD display allows a clear and immediate view of all the main data. The displayed data can also be easily customized to show descriptions, texts, totals, dosage quantity, etc.

KEYBOARD FUNCTIONS FREELY PROGRAMMABLE

It is possible to customize the functions of each keys, by creating specific configurations and automatic sequences, according to the needs. This feature is essential for making simple and immediate, the functions which the operator must perform daily. It is also possible to inhibit the function of each single key, by creating the perfect combination.

CUSTOMIZABLE PRINTOUTS

The print layout is fully customizable according to the specifications.



IP65 / IP68 PROTECTION

All the indicators of the batching line offer a high protection degree against dust and water, and are designed for use in harsh industrial environments.



USB MEMORY

The USB memory stick allows you to download all of the production data of the completed dosages, for further processing from PC.



BLUETOOTH OUTPUT (optional)

This option can be used for quickly programming the formulas inside the instrument, using a smart phone, a tablet or a portable PC.



QUICKLY CONFIGURATION FROM PC WITH DINITOOLS

The Dinitools software for PC, supplied as standard, allows to quickly program and calibrate the indicator and create a database of the installations. These functions allow to quickly replicate the installed systems, saving time.



SOFTWARE FOR THE QUICK CONFIGURATION OF DATABASES

The PC software DBMANAGER allows the quick programming of the databases by using Bluetooth, Ethernet or WiFi interface.



CPWE

Microcontroller for advanced dosage plants



3590ETB

Touch screen microcontroller for advanced batching plants



3590ETT

Touch screen weight indicator for advanced batching plants in a stainless steel case, fitted with bracket.



3590EGT

Touch screen weight indicator for advanced batching plants with mechanical keyboard and integrated traffic light.

MAIN TECHNICAL FEATURES

for DOSAGE/FILLING,
BENCH/PANEL PUNTING



Visit www.diniargeo.com web site for more information.

- As standard
- As option (>> page 26)
- Not available for this model

	DGTQF	DGTQFAN	DGTQPF	DGTQPFAN	DGTQPKF	DGTQPKFAN
PROGRAMMABILITY						
Dosage functionalities	-	-	-	-	-	-
Firmware development area, for customized programs	-	-	-	-	-	-
Fully customizable display	-	-	-	-	-	-
Databases	-	-	-	-	-	-
Standard database for ingredients/formulas	●	●	●	●	●	●
Programmable communication strings	-	-	-	-	-	-
Fully programmable printouts/labels	-	-	-	-	-	-
Selectable multi-language operator interface	-	-	-	-	-	-
USB memory for weighing data storing	-	-	-	-	-	-
SOFTWARE						
Single product dosage in load/unload	●	●	●	●	●	●
Multi-product dosage	●	●	●	●	●	●
Flow rate meter / continuous dosage on conveyor belt	-	-	-	-	-	-
Loss in weight dosage	-	-	-	-	-	-
COMMUNICATION INTERFACES						
Ethernet TCP/IP / WiFi	○	○	○	○	○	○
Modbus TCP / DeviceNET / CanOpen / EtherCat / ProfiNet / Profibus DP	○	○	○	○	○	○
Modbus RTU protocol	●	●	●	●	●	●
RS485 serial port	●	●	●	●	●	●
RS232 serial port	1	1	1	1	1	1
868MHZ Radio frequency module	○	○	○	○	○	○
Alibi memory	-	-	-	-	-	-
USB connection for PC programming with Dinitools software	○	○	○	○	○	○
Bluetooth	-	-	-	-	-	-
IN/OUT						
Electronic outputs	2 + 4 ⁽¹⁾	2 + 4 ⁽¹⁾	6	6	6	6
Digital inputs	2	2	4	4	4	4
Analog output (0...5 Vdc, 0...10 Vdc, 0...20 mA, 4...20 mA)	-	●	-	●	-	●
HARDWARE						
dimensions (mm) (lxhxw - Large x height x width)	96 x 96 x 80		144 x 72 x 129		214 x 196 x 150	
Display	RED LED 13 mm		RED LED 20 mm		RED LED 20 mm	
Waterproof keyboard / integrated traffic light	5 keys / -		5 keys / -		20 keys / -	
Case	ABS					
Power supply	12/24Vdc, 5W					
Operating Temperature Range: Internal use / CE-M / Humidity	-20...+60°C / -10...+40°C / 85%					
IP protection	IP40 front panel					
WEIGHING / OIML						
Connectable load cells	up to 16 of 350Ω, 45 of 1000Ω					
Conversions / Resolution / F.S. max of Display Screen	3200Hz / 24 bit / ± 999999					
Converter / Number of scale inputs	24 bit, 1 channel / 1 scale					
Theoretical calibration (mV/V)	●					
OIML features	3000e, 2x3000e, 6000e, 2x6000e, 10000e					
OIML certifications	R76 / R61 - MID					

(1) with option (>> page 26)

for advanced **DOSAGE**,
PANEL mounting

for advanced **DOSAGE**,
BENCH/WALL mounting



CPWE

3590ETB

3590ETT

3590EGT

●

●

●

●

●

●

●

●

-

●

●

●

●

●

●

●

●

●

●

●

●

●

●

●

●

●

●

●

○

○

○

○

●

●

●

●

○

○

○

○

○

○

○

○

○

○

○

○

○

○

○

○

○

○

○

○

○

○

○

○

●

●

●

●

○

○

○

○

3

3

3

3

○

○

○

○

○

○

○

○

○

○

○

○

4 + 12 ⁽¹⁾

4 + 12 ⁽¹⁾

4 + 12 ⁽¹⁾

4 + 12 ⁽¹⁾

2 + 6 ⁽¹⁾

2 + 6 ⁽¹⁾

2 + 6 ⁽¹⁾

2 + 6 ⁽¹⁾

○

○

○

○

202 x 105 x 148

265 x 175 x 90

298 x 203 x 110

280 x 143 x 185

graphic LCD

Touch screen 5,7"

Touch screen 5,7"

Touch screen 5,7"

24 keys / -

- / -

- / -

15 keys / ●

ABS/Aluminium

ABS/Stainless Steel

ABS/Stainless Steel

Stainless Steel

12/24Vdc, 30W

12/24Vdc, 50W

230Vac, 50W

230Vac, 50W

-20...+60°C / -10...+40°C / 85%

-20...+60°C / -10...+40°C / 85%

IP65 front panel

IP65 front panel

IP65

IP68

up to 16 of 350Ω, 45 of 1000Ω

up to 16 of 350Ω, 45 of 1000Ω

3200Hz / 24 bit / ± 999999

3200Hz / 24 bit / ± 999999

24 bit, 4 channels / 4 independent scales

24 bit, 4 channels / 4 independent scales

●

●

3000e, 2x3000e, 3x3000e, 6000e, 2x6000e, 10000e

3000e, 2x3000e, 3x3000e, 6000e, 2x6000e, 10000e

R76 / R61 - MID

R76 / R51 - MID / R 134

SINGLE COMPONENT DOSAGE IN LOADING

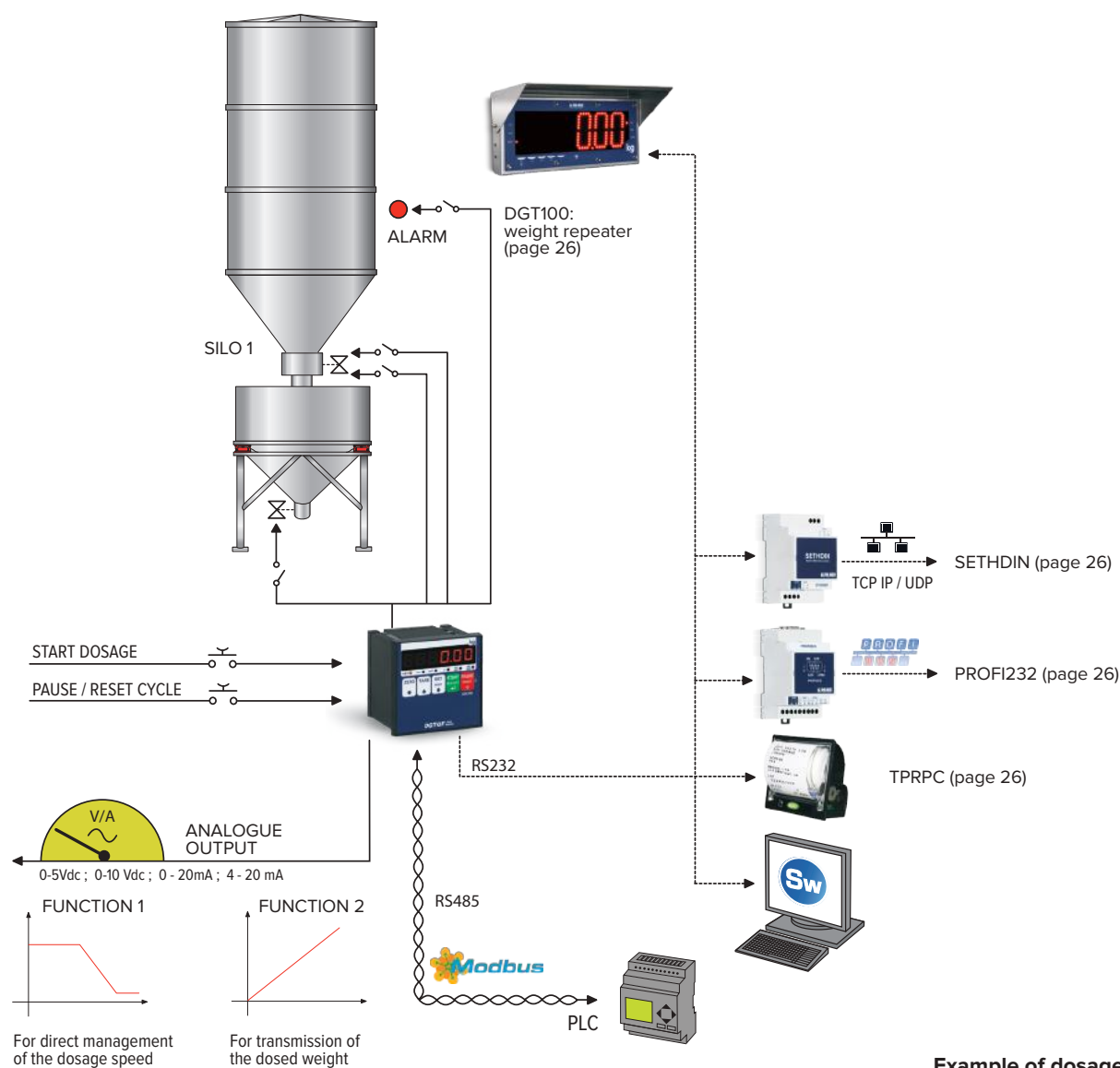

**DATABASE 40
FORMULAS**



**AVAILABLE
FOR ATEX ZONE
1 & 21 e 2 & 22**

**Example of dosage system using the
DGTQF for loading routine**

FUNCTIONS OF THE STANDARD PROGRAM

- Automatic dosage in loading with dual speed.
- Quick change of the target to be dosed.
- Checking of the tare presence at the dosage start; the tare values are programmable for each formula.
- Automatic printing of the dosage data.
- Recording and printing of the quantities.
- Automatic correction of flight weight.
- Programmable repetitions of the dosage cycles / infinite cycle function.
- Tolerance test on the dosed weight, with guided correction on display.
- Check of the maximum dosage time.
- Alarms indication on display.
- Digital or theoretical calibration and configuration from keyboard.
- Digital or theoretical calibration and configuration from PC via Dinitools, with the possibility of storing

the setup of the instrument to backup, simplify the technical assistance, or replicate the same configuration on other instruments (OEM).

- Quick recalibration of the zero point.
- Dini Argeo protocol for programming the formulas at distance.
- Quick interface with ETHERNET, PROFIBUS, WIFI, USB module, IN / OUT expansion.

WORK CYCLE

1. Once the dosage start command is received, the presence of the tare and weight stability is verified, with the execution of the automatic tare and the enabling of the automation through its dedicated outputs: the dosages start at maximum speed.
2. Once the speed change threshold is reached, the dosage is slowed down through the dedicated output.
3. When the TARGET cutoff point is reached, the slow dosage output is disabled and then it waits (for the configured time) for the in-flight material to complete the cycle.
4. The dosed weight is then checked for tolerance and if correct added to the ingredient total and the overall machine total.
5. Completed discharging can be controlled through enabling of dedicated outputs.
6. End dosage or automatic restart for following cycle, with update of the ingredient and machine totals.

SINGLE COMPONENT DOSAGE FOR DISCHARGE

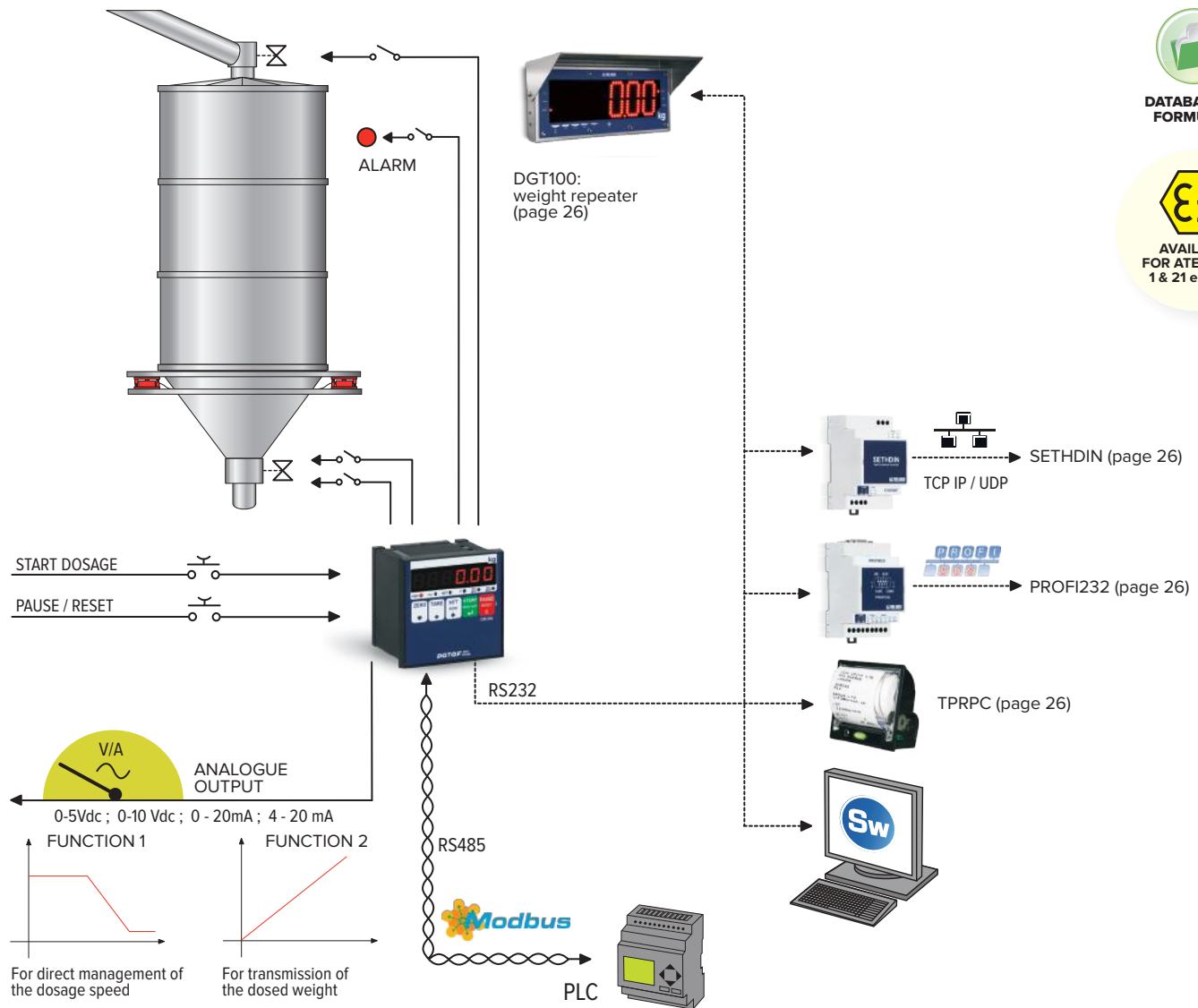

Example of dosage system for discharging with the DGTQF

FUNCTIONS OF THE STANDARD PROGRAM

- Automatic dosage for discharge with dual speed.
- Quick change of the target to be dosed.
- Automatic printing of the dosage data.
- Automatic management of the refilling of the silo using a dedicated contact.
- Recording and printing of the quantities.
- Automatic correction of in-flight weight.
- Programmable repetitions of the dosage cycles / infinite cycle function.
- Tolerance test on the dosed weight, with guided correction on display.
- Check of the maximum dosage time.
- Alarms indication on display.
- Digital or theoretical calibration and configuration from keyboard.
- Digital or theoretical calibration and configuration from PC via Dinitools, with the possibility of storing the setup of the instrument to backup, and replicate the same configuration on other instruments (OEM).
- Quick recalibration of the zero point.
- Dini Argeo protocol for remote programming of new formulas.
- Quick interface with ETHERNET, PROFIBUS, WIFI, USB module, IN / OUT expansion.

WORK CYCLE

1. Once the dosage start command is received, the instrument verifies that the quantity of material is sufficient to execute the programmed cycle. If the weight is sufficient, it executes the automatic tare and the enabling of the automation through its dedicated outputs: the dosages start at maximum speed.
2. Once the speed change threshold is reached, the dosage is slow down through the dedicated output.
3. When the TARGET cutoff point is reached, the slow dosage output is disabled and then it waits (for the configured time) for the in-flight material to complete the cycle.
4. The dosed weight is then checked for tolerance and if correct added to the ingredient total and the overall machine total.
5. Recharge of the silo up to the programmed threshold or automatically restarts with the following cycle.

MULTI COMPONENT DOSAGE

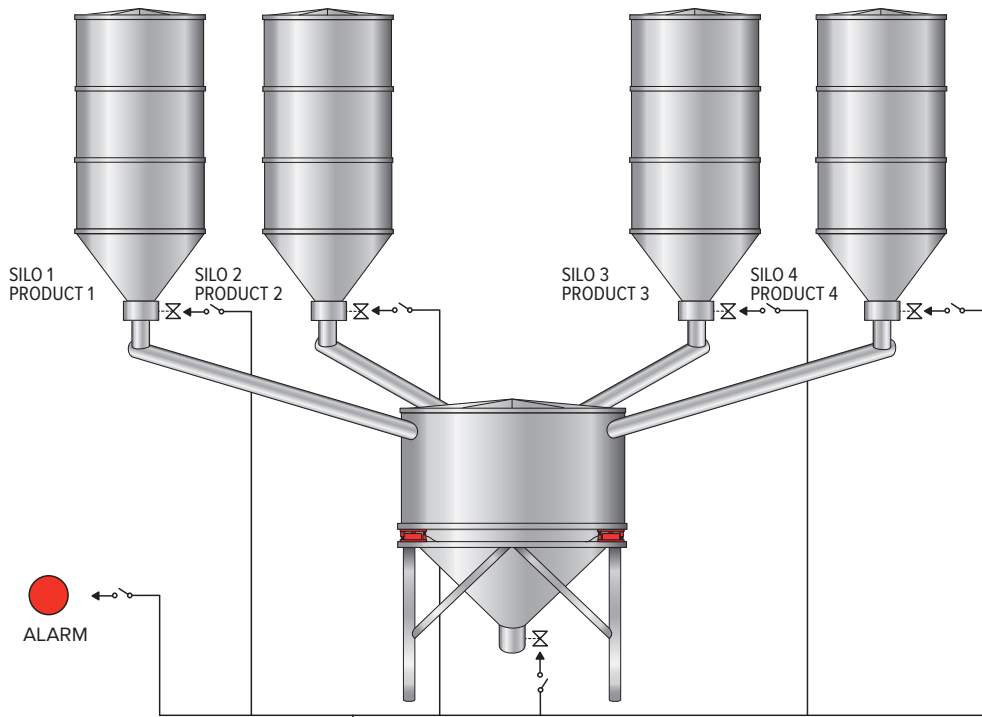

DATABASE 16 PRODUCTS



DATABASE 15 FORMULAS WITH 8 PRODUCTS EACH ONE



4 DIRECT PRODUCTS WITH DUAL SPEED



3 DIRECT PRODUCTS WITH DUAL SPEED + DOWNLOAD



2 DIRECT PRODUCTS WITH DUAL SPEED + 2 DOWNLOADS



AVAILABLE FOR ATEX ZONE 1 & 21 e 2 & 22

START DOSAGE

PAUSE / RESET



ANALOGUE OUTPUT
0-5Vdc ; 0-10 Vdc ; 0 - 20mA ; 4 - 20 mA

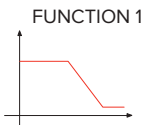

FUNCTION 1
For direct management of the dosage speed

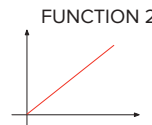

FUNCTION 2
For transmission of the dosed weight



RS232

RS485

Modbus

PLC



DGT100 (page 26)



SETHDIN (page 26)

TCP IP / UDP



PROFI232 (page 26)

RS485



TPRPC (page 26)



Example of multi component dosage system with DGTQF

FUNCTIONS OF THE STANDARD PROGRAM

- Database 16 products/phases.
- Database 15 formulas.
- Automatic management of 4 products in filling with dual speed, or 3 products in filling with dual speed and total discharging, or 2 products in filling and 2 discharging etc.
- Checking the presence of the tare at the dosage start.
- Automatic printing of the dosage data.
- Automatic correction of in-flight weight.
- Programmable repetitions of the dosage cycles / infinite cycle function.
- Tolerance test on the dosed weight, with guided correction on display.
- Check of the maximum dosage time.
- Alarms indication on display.

WORK CYCLE

1. Once the dosage start command has been received, the following takes place:
 - the presence of the tare and weight stability is verified,
 - the execution of the automatic tare and the enabling of the automation through the dedicated outputs: the instrument executes the first phase of the formula.
2. Once the first phase is finished, the instrument automatically passes to the following phase, executing the automatic tare.
3. At the end of the last configured phase, the instrument enables the fine cycle contact and waits for the start of the new dosage, or automatically restarts with the following cycle.

SINGLE COMPONENT DOSAGE IN FILLING (UP TO 4 SILOS)

Dini Argeo offers a complete range of indicators for single component dosage filling, featured by high performances, easy-to-use and fitted with various functions.

The standard input/output allows you to create advanced automations directly managed from the indicator; the keybo functions and the displayed data are

completely customizable. All indicators are approved for legal for trade use, according to EN45501, OIML R76.

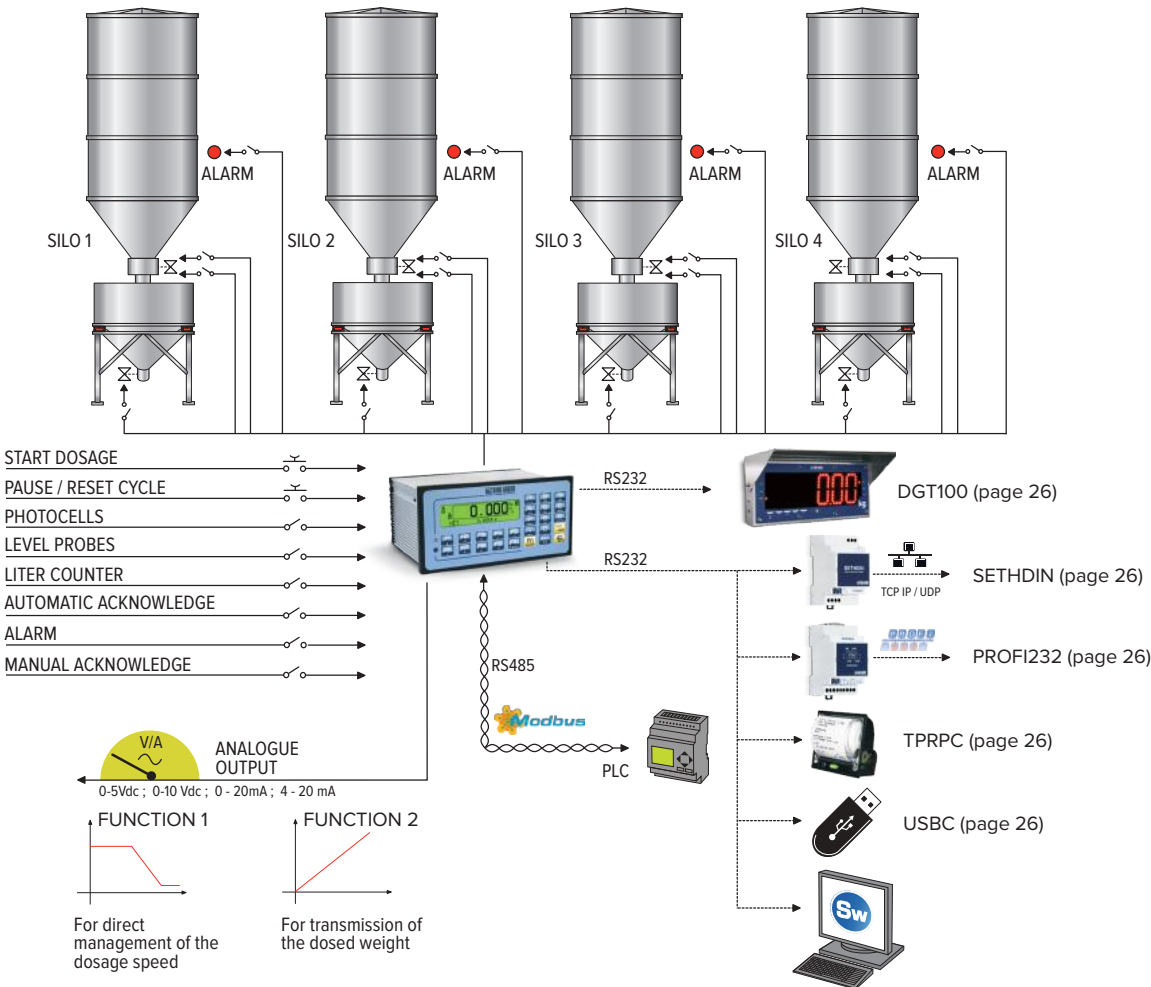

DATABASE 500 FORMULAS



AVAILABLE FOR ATEX ZONE 1 & 21 e 2 & 22

Example of filling dosage system with CPWE

FUNCTIONS OF THE STANDARD PROGRAM

- Single component, multi scale dosage in filling with dual speed.
- Database 500 formulas which can be quickly recalled from keyboard and programmed from Dinitools.
- Quick change of the target to be dosed.
- Checking of the tare presence at the dosage start; the tare values are programmable for each formula.
- Automatic printing of the dosage data.
- Recording and printing of the quantities.
- Automatic correction of flight weight.
- Programmable repetitions of the dosage cycles / infinite cycle function.
- Tolerance test on the dosed weight, with guided correction on display.
- Check of the maximum dosage time.
- Alarms indication on display.
- Digital or theoretical calibration and configuration from keyboard.
- Digital or theoretical calibration and configuration from PC via Dinitools, with the possibility of storing the setup of the instrument to backup, simplify the technical assistance, or replicate the same configuration on other instruments (OEM).
- Quick recalibration of the zero point.
- Dini Argeo protocol for programming the formulas at distance.

WORK CYCLE

1. Once the dosage start command is received, the presence of the tare and weight stability is verified, with the execution of the automatic tare and the enabling of the automation through its dedicated outputs: the dosages start at maximum speed.
2. Once the speed change threshold is reached, the dosage is slow down through the dedicated output.
3. When the TARGET is reached and the configured flight weight is missing, the slow dosage output is disabled and then it waits (for the configured time) for the dropping of the material.
4. Tolerance test on the dosed weight, storage of the formula consumptions and increment of the dosed general total.
5. Complete unloading request, through enabling of dedicated output.
6. End dosage or automatic restart for following cycle, with increment of the consumptions and the totals.

SINGLE COMPONENT DOSAGE IN UNLOADING (UP TO 4 SILOS)

Dini Argeo offers a complete range of indicators for single component dosage in discharging, featured by high performances, easy-to-use and fitted with various functions.

The standard input/output allows you to create advanced automations directly managed from the indicator; the keyboard functions and the displayed data are completely customizable.

All indicators are approved for legal for trade use, according to EN45501, OIML R76.

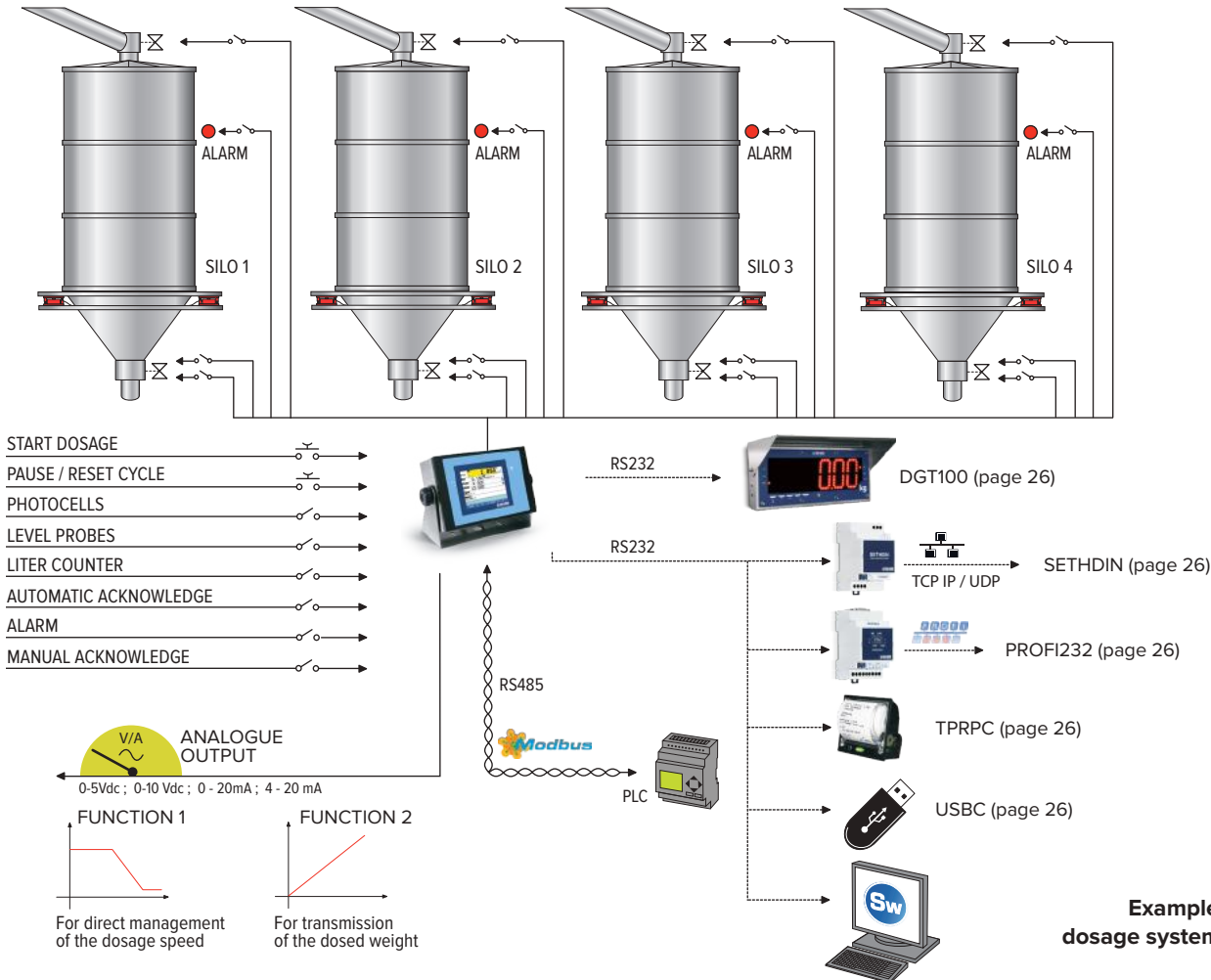

DATABASE 500
FORMULAS



AVAILABLE
FOR ATEX ZONE
1 & 21 e 2 & 22

FUNCTIONS OF THE STANDARD PROGRAM

- Single component, multi scale dosage in unloading with dual speed.
- Database 500 formulas which can be quickly recalled from keyboard and programmed from Dinitools.
- Quick change of the target to be dosed.
- Automatic printing of the dosage data.
- Recording and printing of the quantities.
- Automatic correction of flight weight.
- Programmable repetitions of the dosage cycles / infinite cycle function.
- Tolerance test on the dosed weight, with guided correction on display.
- Check of the maximum dosage time.
- Alarms indication on display.
- Digital or theoretical calibration and configuration from keyboard.
- Digital or theoretical calibration and configuration from PC via Dinitools, with the possibility of storing the setup of the instrument to backup, simplify the technical assistance, or replicate the same configuration on other instruments (OEM).
- Quick recalibration of the zero point.
- Dini Argeo protocol for programming the formulas at distance.

WORK CYCLE

1. Once the dosage start command is received, the presence of the tare and weight stability is verified, with the execution of the automatic tare and the enabling of the automation through its dedicated outputs: the dosages start at maximum speed.
2. Once the speed change threshold is reached, the dosage is slow down through the dedicated output.
3. When the TARGET is reached and the configured flight weight is missing, the slow dosage output is disabled and then it waits (for the configured time) for the dropping of the material.
4. Tolerance test on the dosed weight, storage of the formula consumptions and increment of the dosed general total.
5. End dosage or automatic restart for following cycle, with increment of the consumptions and the totals. Possible automatic recharge of the silo through a dedicated relay.

MULTI-PRODUCT SEQUENTIAL DOSAGE

Dini Argeo offers a complete range of advanced indicators for the sequential automatic dosage with various products (up to 100). The basic functioning provides a quick and easy programming of formulas which recall

sequentially the dosage activities at two speeds and the discharging activities of the final mixture, with the possibility of a time management of the mixers or burners in parallel to the dosage activity.

Thanks to the great configurability and integrated development area, one can completely customize the dosage cycle and the keyboard functions according to one's needs, adapting the instrument to every application.

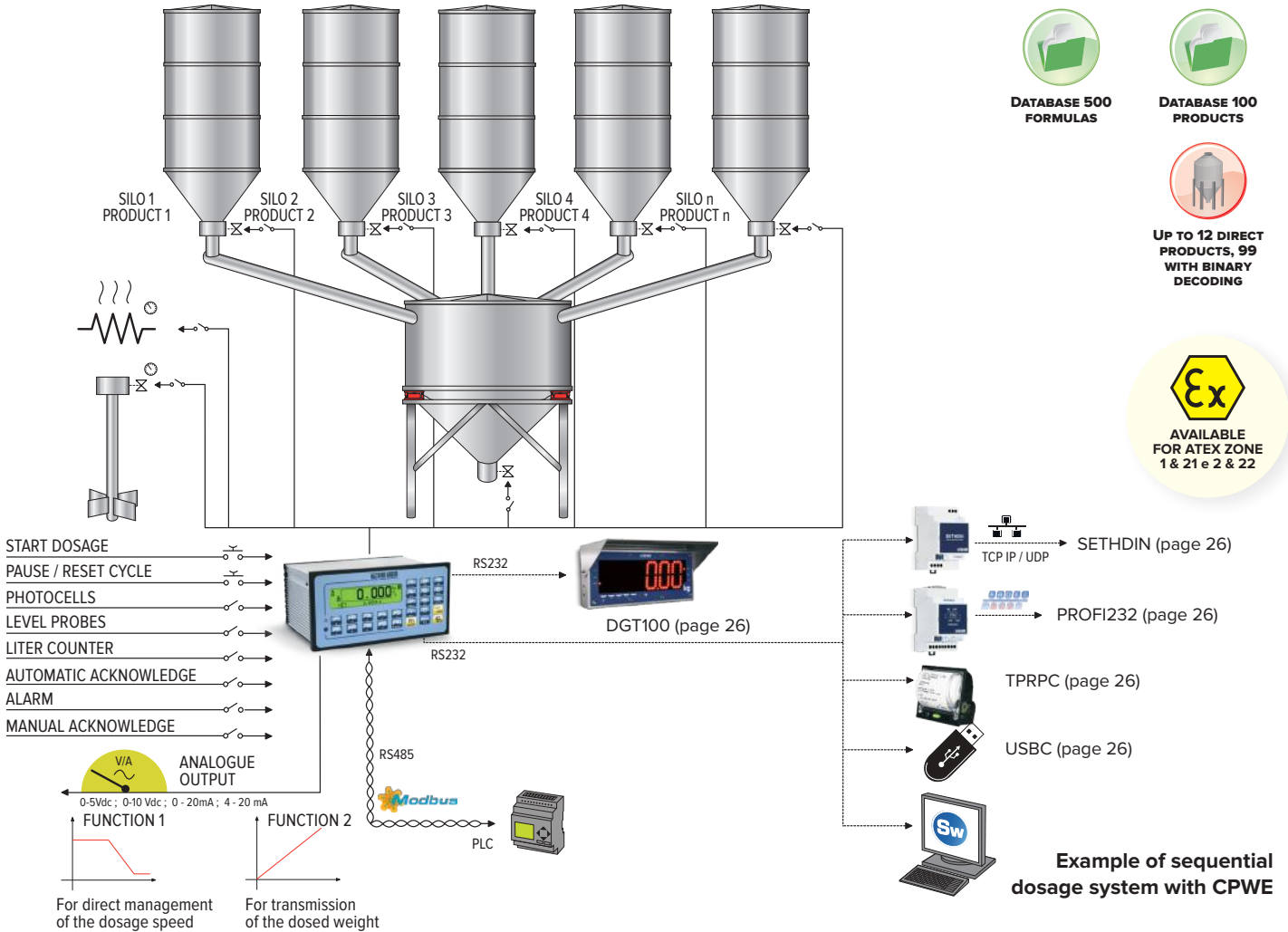

DATABASE 500 FORMULAS

DATABASE 100 PRODUCTS

UP TO 12 DIRECT PRODUCTS, 99 WITH BINARY DECODING

AVAILABLE FOR ATEX ZONE 1 & 21 e 2 & 22

SETHDIN (page 26)

PROFI232 (page 26)

TPRPC (page 26)

USBC (page 26)

Example of sequential dosage system with CPWE

FUNCTIONS OF THE STANDARD PROGRAM

- Management of the dosage on various scales (up to 4 independents), with automatic change of the scale during the dosage.
- Database 100 products/activities.
- Database 500 formulas; each formula contains 20 products/activities.
- Checking of the tare presence at the dosage start; the tare values are programmable for each formula.
- Automatic recalculation of the formula targets, by entering the total weight to be dosed.
- Automatic printing of the dosage data.
- Recording and printing of the quantities with quick recall of the printouts from keyboard.
- Automatic correction of flight weight.
- Programmable repetitions of the dosage cycles / infinite cycle function.
- Tolerance test on the dosed weight, with guided correction on display.
- Check of the maximum dosage time.
- Alarms indication on display.
- Completely programmable printouts, for compatibility with any ASCII printer manageable through the serial port.

WORK CYCLE

1. Once the dosage start command has been received, the following takes place:
 - the presence of the tare and weight stability is verified,
 - the execution of the automatic tare and the enabling of the automation through the dedicated outputs: the instrument executes the first phase of the formula.
2. Once the first phase is finished, the instrument automatically passes to the following phase, executing the automatic tare.
3. At the end of the last configured phase, the instrument enables the fine cycle contact and waits for the start of the new dosage, or automatically restarts with the following cycle.

SIMULTANEOUS MULTI-PRODUCT DOSAGE/BATCHING PLANTS

This application is realized by using a BATCHING main indicator connected in a RS485 network with two or more FILLING indicators, each one able to manage the dosage of one or more products. The main

advantages of this application are the execution speed of the formula, thanks to the simultaneous dosage of various products, and the system modularity, which can be implemented in any moment with new

modules. The dosage formulas are contained in the main control unit, while the dosage of each single product is inside the system. In this way, each remote indicator can be managed also in manual mode out of the dosage cycle.

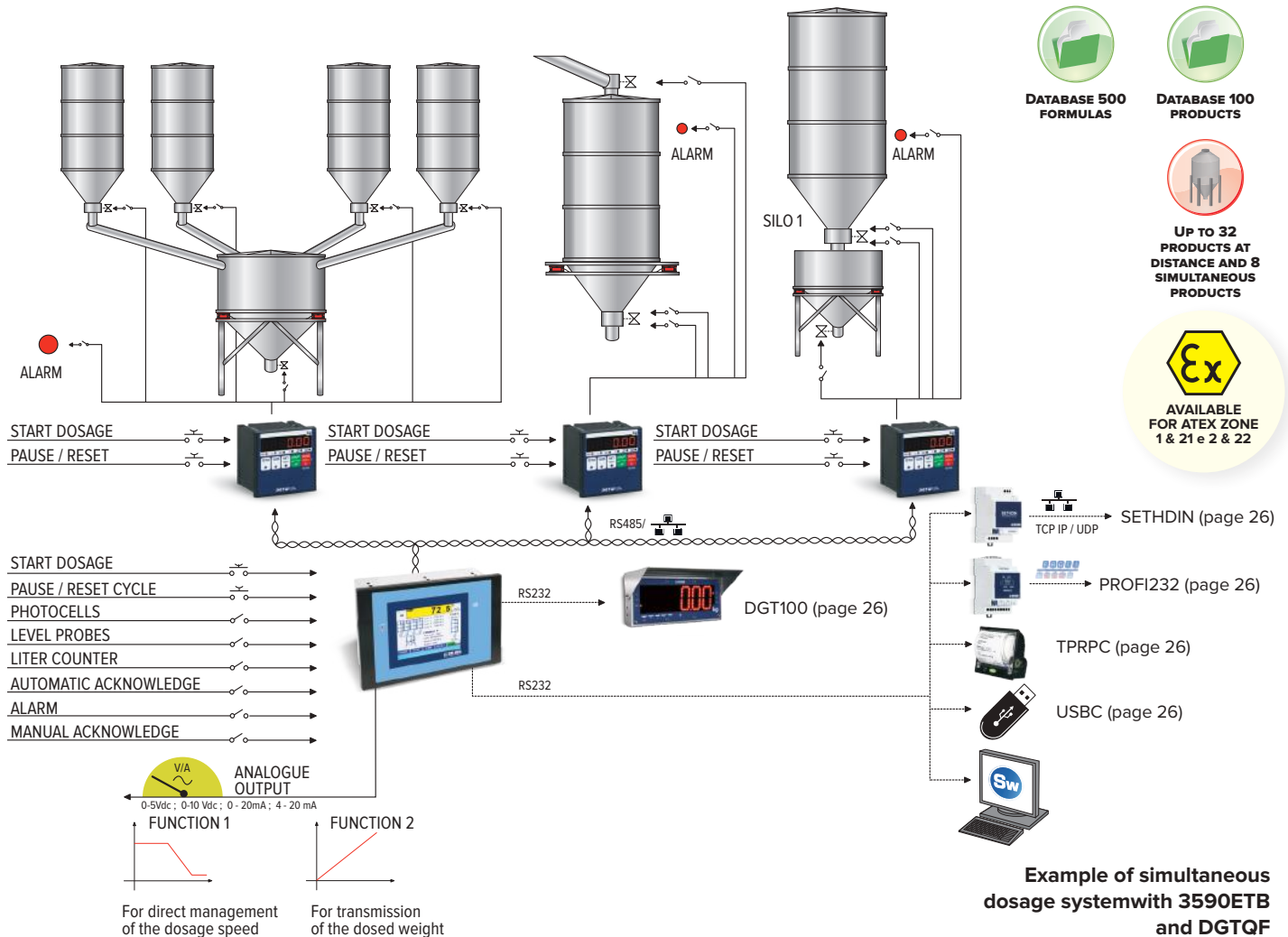

FUNCTIONS OF THE STANDARD PROGRAM

- Management of the dosage on various scales (up to 4 independents), with automatic change of the scale during the dosage.
- Database 100 products/activities.
- Database 500 formulas; each formula contains 20 products/activities.
- Checking of the tare presence at the dosage start; the tare values are programmable for each formula.
- Automatic recalculation of the formula targets, by entering the total weight to be dosed.
- Automatic printing of the dosage data.
- Recording and printing of the quantities with quick recall of the printouts from keyboard.
- Automatic correction of flight weight.
- Programmable repetitions of the dosage cycles / infinite cycle function.
- Tolerance test on the dosed weight, with guided correction on display.
- Check of the maximum dosage time.
- Alarms indication on display.
- Completely programmable printouts, for compatibility with any ASCII printer manageable through the serial port.

WORK CYCLE

1. Once the dosage start command has been received, the main control unit commands the dosage of each component, by sending specific commands to remote indicators interested.
2. During the dosage, the main control unit checks in real time each indicator, by alerting the operator about faults. Each indicator doses simultaneously to the others.
3. At the end of the dosage, the check on each dosed weight is executed and it is possible to communicate all the data to PC or print the total report.

BELT: CONTINUOUS DOSAGE ON BELT

Dini Argeo offers solutions for conveyor belts, for the real-time weighing and dosage of the material in transit. The system is made up of one or more weighing bars / load cells, connected to the

main weight indicator, which can read and adjust the hourly flow rate of the material flow and automatically stop the dosage once the programmed set point is reached. Thanks to the Modbus RTU and Profibus

DP protocol, it is possible to interface the system with a PLC, or via Ethernet interface, connect it to the information company network.

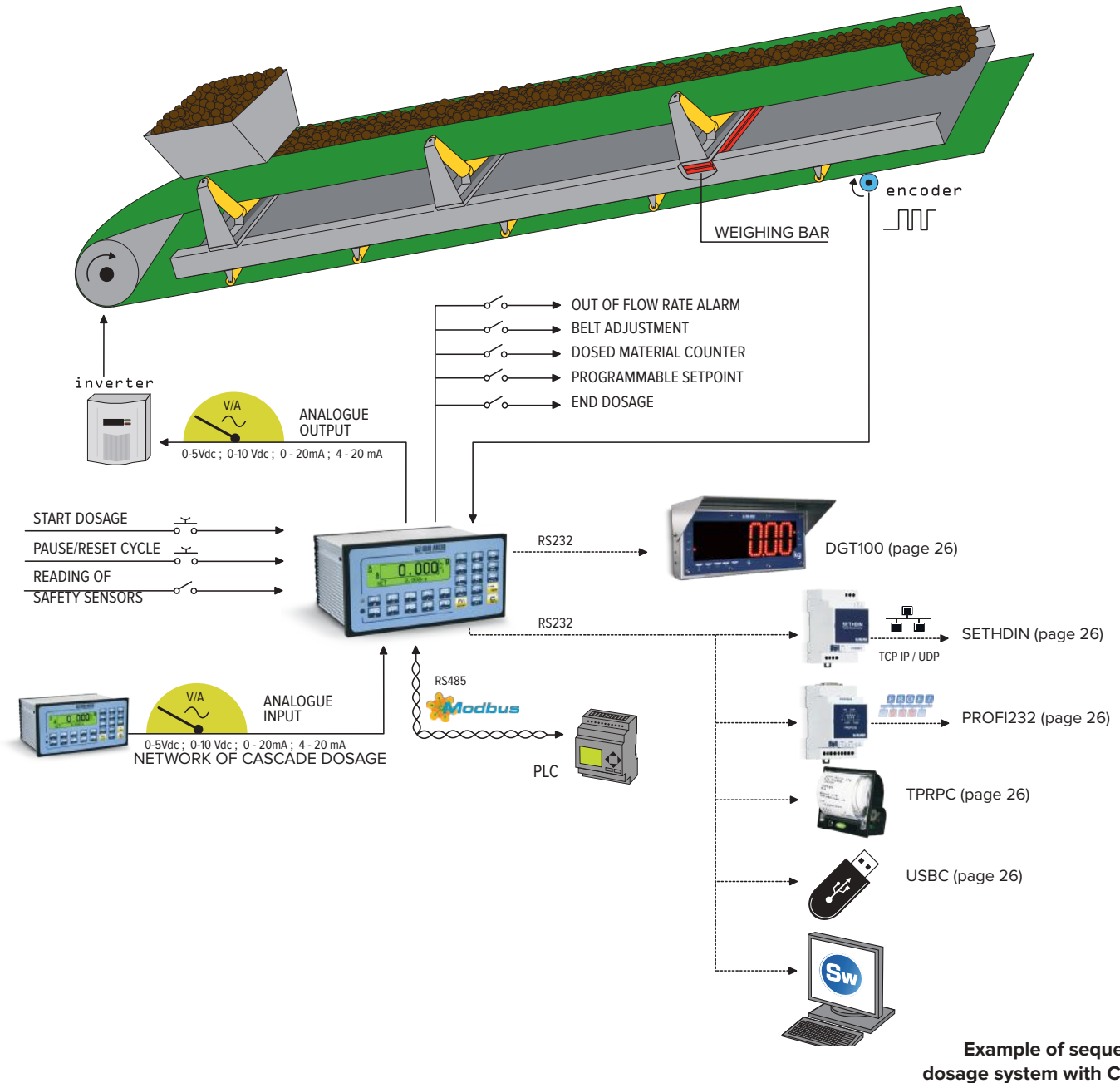

Example of sequential dosage system with CPWE

FUNCTIONS OF THE STANDARD PROGRAM

- 2 selectable operation modes:
 - Instantaneous reading of the flow, in kg/h or t/h with displaying of the status of the system and of the dosed total.
 - Adjustment of the dosage hourly flow, in function of the pre-set target, with PID algorithm.
- Display of the hourly flow graph and wide range of data displayed on the display.
- Calibration of the flow reading function, for controlling the dosage performances.
- Reading filter of the hourly flow with configurable incidence and speed depending on the system.
- Programmable dosage target upon weight or upon time, with relative contact.
- Programmable start dosage delay, for synchronisation of various E-BELT systems in the dosage of material mixtures.
- Management of the slow flow with programmable activation threshold, for more precise dosages.
- Management of the dosage total under way and general total of dosages, printable and clearable independently from each other.
- Management of the automatic dosage from remote master or through Profibus DP or Modbus RTU protocol.
- Printing of the dosage data and the total.
- Completely programmable printouts, for compatibility with any ASCII printer manageable through the serial port.

LW: CONTINUOUS DOSAGE IN UNLOADING

Software version for the measurement/integration of the weight, the flow of material exiting from silos, tanks, or hoppers, with

recording of the quantity of dosed material; possibility of adjusting the flow through the 16 bit analogue output and the PID control.

Option of the remote management of the instrument through Modbus RTU or Profibus protocols.

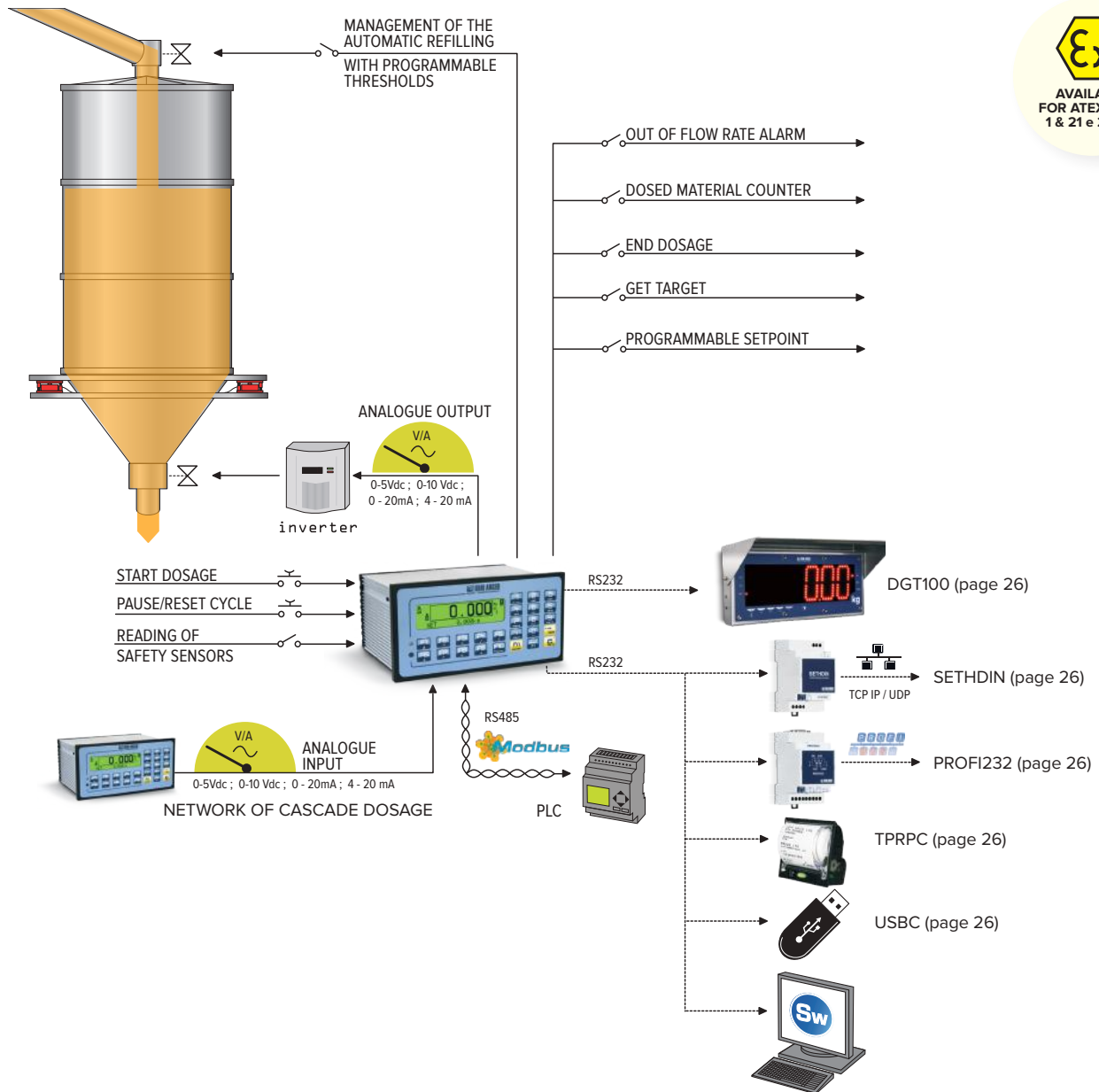

FUNCTIONS OF THE STANDARD PROGRAM

- 2 selectable operation modes:
 - Instantaneous reading of the flow, in g/h, kg/h or t/h with displaying of the status of the system and of the dosed total.
 - Adjuster of the dosage hourly flow, in function of the pre-set target, with PID algorithm.
- Display of the hourly flow graph and wide range of data displayed on the display.
- Calibration of the flow reading function, for perfecting the dosage performances.
- Reading filter of the hourly flow with configurable incidence and speed depending on the system.
- Programmable dosage target upon weight or upon time, with relative contact.
- Programmable delay at the start, for synchronisation of various E-LW systems in the dosage of material mixtures.
- Management of the slow flow with programmable activation threshold, for more precise dosages.
- Management of the dosage total under way and general total of dosages, printable and clearable independently from each other.
- Management of the automatic dosage from remote master or through Modbus RTU or Profibus protocols.
- Printing of the dosage data and the total.
- Completely programmable printouts, for compatibility with any ASCII printer manageable through the serial port.



THE FUNCTIONS OF THE WEIGHT INDICATORS CAN BE EXTENDED
THANKS TO THE WIDE RANGE OF AVAILABLE ACCESSORIES

INTERFACE, EXPANSIONS AND ACCESSORIES



ETH Ethernet interface

Network interface	10/100 Base-T
Protocols	TCP, UDP, DHCP, SNMP, SSL 3.0/TLS 1.0, HTTP, SMTP, ICMP, IGMP, ARP



BLTH Bluetooth interface

Class	2
Maximum working distance (in optimal conditions)	10m
Transmission speed	9600 baud/300 kbps
Standard bluetooth	2.0 + EDR



DAC160 Analogue output

Configurations	0..5Vdc / 0..10Vdc / 0..20mA / 4..20mA
Resolution / Precision	16 bit / 0,08% F.S.
Update frequency	50Hz



WIFIT Wi-Fi interface

Type	WiFi IEEE 802.11b
Capacity	70m outdoor - 30m indoor
Frequency	2.4 GHz
Data Rate	11 Mbps con automatic fallback
Protocols and functioning modes	foreseen by the IEEE 802.11b, including WEP (cryptology)



ADC161 Analogue input

Configurations	0..5Vdc / 0..10Vdc / 0..20mA / 4..20mA
Resolution / Precision	16 bit / 0,08% F.S.
Reading speed	100Hz



SETDIN
Ethernet / RS485 / RS232
Converter
for DIN bar

Ethernet protocols	TCP, UDP, DHCP, SNMP HTTP, SMTP, SSL 3.0/TLS 1.0, ICMP, IGMP, ARP.
Ethernet network interface	10/100 Base-T
Ethernet communication speed	10-100Mbps
Operating temperature	-10..+50°C



DGT100R
Universal weight repeater

Case	Stainless steel IP68
Display	100mm very bright red SMD LEDs



PROFI232
RS232 / PROFIBUS DP
Converter
for DIN bar

Power supply	12/24Vdc - 12W
Speed	9,6 Kbit/s..12Mbit/s
Input	RS232
Output	Profibus DP slave (IEC 61158)



RSCBUSB
USB 2.0 interface

interface support	UART for 7 or 8 data bits, 1 or 2 stop bits and odd / even / mark / space / no parity
-------------------	---



USBDIN
RS485 / RS232
Converter
for DIN bar

Input	RS232 o RS485
USB port for data storing, more than 5.000.000 weighs	
Remote data reading by serial communication	



OBRF232
Radio frequency module
868 MHz

Power supply	external power supplier
Input signal	RS232
Case	ABS IP65 120x80x55mm
Cable	RS232, 3m long



USBC
USB memory
with extractable key

Recording weighs	up to 5.000.000
Recording format	Text (.txt) or Excel (.csv)



TPRPC
Thermal printer for panel
mounting

Paper width / Roll max. diameter	58mm / 50mm
Print speed	up to 50mm/sec
Resolution	203 dpi



PROFIBUS1S

Input	RS485 (Quick Connect) or RS232
Output	Profibus DP



WIFI1S

Input	RS485 (Quick Connect) or RS232
Output	WiFi



ETHERCAT1S

Input	RS485 (Quick Connect) or RS232
Output	EtherCat



ETHERNET1S

Input	RS485 (Quick Connect) or RS232
Output	Ethernet TCP/IP - UDP



PROFINET1S

Input	RS485 (Quick Connect) or RS232
Output	ProfiNet



DEVICENET1S

Input	RS485 (Quick Connect) or RS232
Output	DeviceNET



CANOPEN1S

Input	RS485 (Quick Connect) or RS232
Output	CanOpen



QUICK CONNECT

Thanks to the “quick connect” system, available on the SLIM case devices, the connection between modules is faster and easier.



PC SOFTWARE FOR CONFIGURING THE WEIGHT INDICATORS

DINITOOLS

- Management of the customers and designers systems databases, with recording of attachments, pictures, etc.
- Recording of the current configuration of the designed system to simplify and speed up any future replies.
- Calibration of the scale with use of the sample weights, with up to 8 linearisation points.
- Theoretical calibration, by entering the data of the system to be made.
- Pre-calibration of the indicator's electronic card.
- Digital equalization.
- Modify/send/receive all the set-up parameters of the connected scale, with the subsequent recording of the executed configuration.
- Quick and easy compilation of the databases.
- Customization of the printout layout.

SOFTWARE FOR MANAGING THE WEIGHTS FROM DINI ARGEO SCALES

WEIMONITOR

WeiMonitor is our PC program which allows you to monitor and record in real time all the weights made on the connected scale, storing them in a text or Excel file for further processing.



WEIGHING AND DOSAGE SYSTEMS

LOAD CELLS and MOUNTING KITS



INDUSTRY



LOGISTICS



BUILDING



BOATYARD

WOOD
INDUSTRY

FUELS

Dini Argeo offers a complete range of high quality load cells and mounting kits, manufactured with the latest technology ensuring accuracy and reliability.

HIGH QUALITY MATERIALS

The load cells and assembly kits, offered by Dini Argeo, are made of electro-polished stainless steel.

COMPACT SIZES

The kits are designed for an easy installation at the bottom of the silos, hoppers, tanks, minimizing the change in the overall height of the system.



OIML R60

Each load cell is made according to the specifications indicated on the OIML R60.

The SBX, DSBI, FXC, FXD, SP, SPS and ST load cells are also approved for legal for trade use.



OVERLOAD-PROOF SCREW JACKS

The overload-proof screw jacks are essential for quickly installing / replacing the load cell and ensuring the maximum protection during the transport, even if already installed.



IP68 PROTECTION DEGREE

The load cells are hermetically protected from dust, water and moisture, suitable for use in harsh industrial environments or with strict hygiene requirements.

THE RANGE



SBX
Shear Beam



CPX
Compression



DSBI
Double Shear Beam

LAOD CELLS CAPACITIES

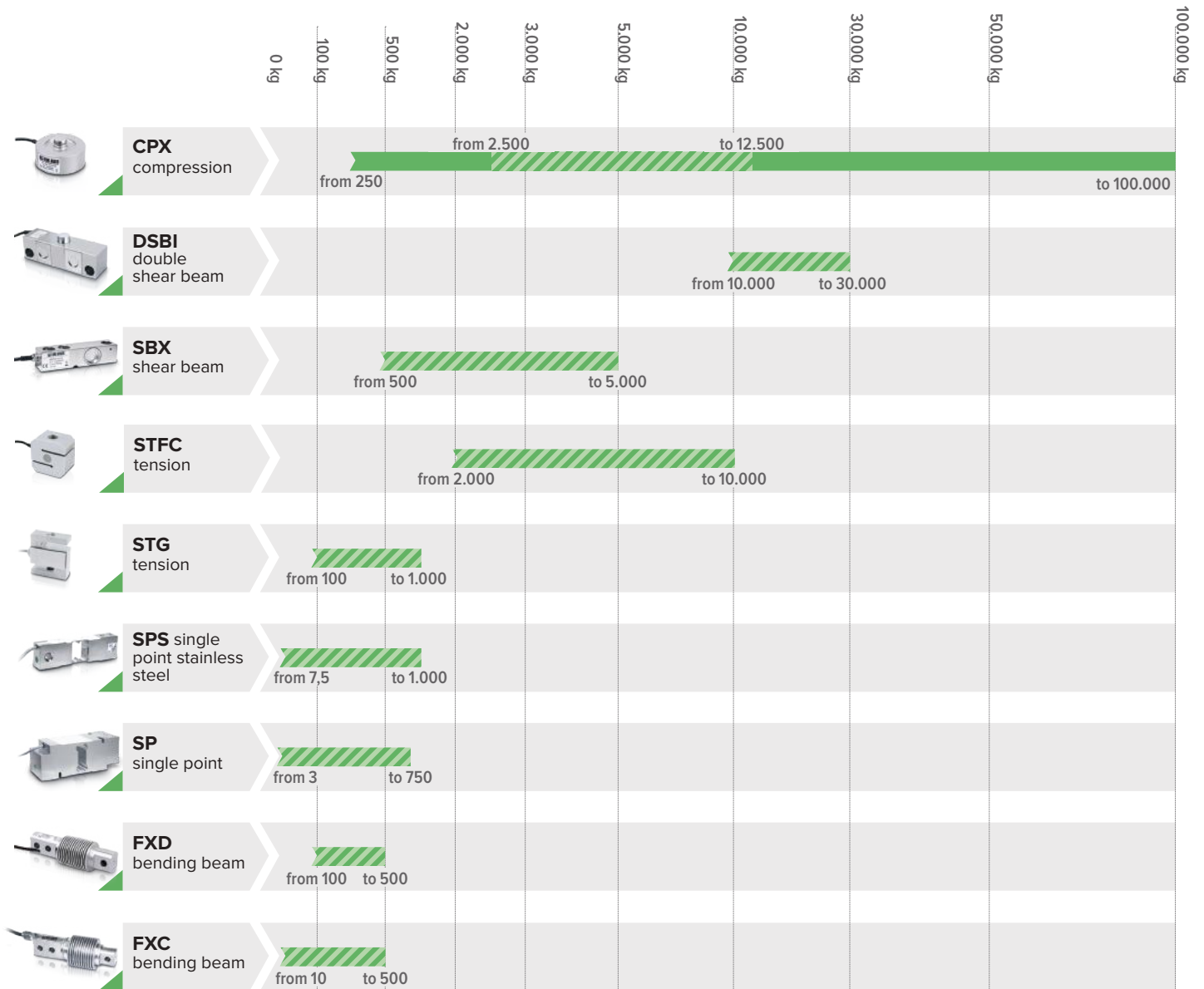

 OIML certifications



FXC-FXD
Bending Beam



SP-SPS
Single Point



ST
Tension

SHEAR BEAM LOAD CELLS FROM 500 TO 5000 kg

SBX

High performance, stainless steel shear beam load cells, extremely robust and resistant, with IP68 protection classification.

Particularly suitable for creating CE-M approved 4-cell scales with medium capacity, and for weighing tanks, silos, and hoppers, thanks to the KSB and KSBN assembly kits.

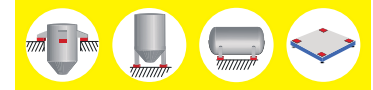

AVAILABLE ALSO
IN ATEX CERTIFIED
VERSION

ATEX II 1G Ex ia IIC T6
(Ta -20÷+40°C)
TX (Ta -20÷+65°C) Ga
ATEX II 1D Ex ta IIIC TX°C
(Ta -20÷+40°C)
TX°C (Ta -20÷+65°C) Da IP65

SBX FROM 500 TO 2000 kg

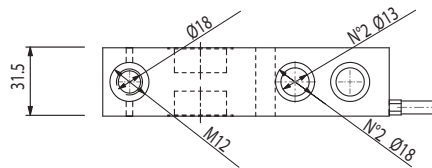
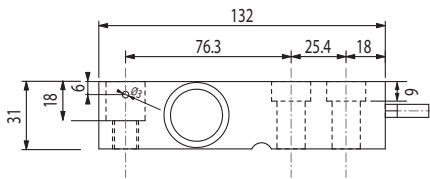

TECHNICAL FEATURES

Accuracy class	C3
Protection classification	IP68
Construction	17-4 PH stainless steel
Minimum load cell verification interval (Vmin)	EMax/10000
Maximum number of verification intervals	nLC=3000
Combined error of Full Scale Output (F.S.)	0.017%
Full Scale Output	2mV/V ± 0.5%
Temperature effect on zero	0.002% / °C
Temperature effect on full scale output	0.002% / °C
Compensated Temperature	-10°C / +50°C
Operating Temperature	-20°C / +60°C
Creep error after 30 minutes	0.02% F.S
Maximum tolerated excitation voltage	15 Vdc
Input Resistance	1100 ± 20 Ohm
Output Resistance	1000 ± 20 Ohm
Insulation Resistance	>5000 MOhm
Safe Overload	150% F.S
Ultimate Overload	>300% F.S
Shielded cable	5m, Ø5mm/6-wire

SBX FROM 3000 TO 5000 kg

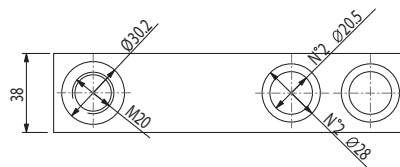
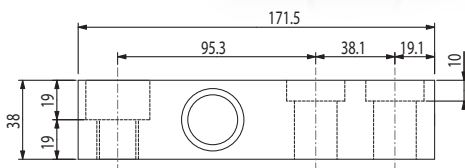

Code

Max capacity (kg)

SBX500-1K / 1000-1KL / 2000-1KL

500 / 1000 / 2000

SBX3000-1K / 5000-1KL

3000 / 5000

KSB: ASSEMBLY KIT FOR SHEAR BEAM LOAD CELLS

Assembly kits for SBX series shear beam load cells, suitable for creating high-capacity weighing platforms, or for weighing silos, hoppers, horizontal or vertical tanks with a medium or large size.

- ✓ The special articulation ensures excellent measurement accuracy even with an expanded or bent structure to be weighed.
- ✓ Adjustable height for an optimal leveling of the structure to be weighed.

- **KSB2 AND KSB5 VERSIONS: EXECUTION IN AISI304 STAINLESS STEEL WITH HINGE ADJUSTABLE IN HEIGHT**
- **KSBN2 VERSION: EXECUTION IN GALVANIZED STEEL WITH SPHERICAL JOINT**
- **MECHANICAL COMPENSATION OF THERMAL SWELLINGS AND TRANSVERSAL FORCES**



INOX
AISI 304

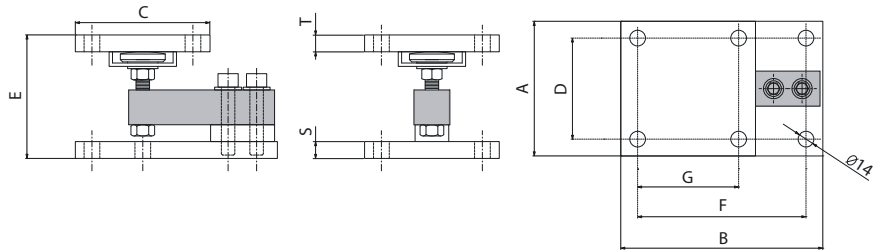

Code	Max capacity (kg)	Dimensions (mm)								
		A	B	C	D	E	F	G	S	T
KSBN2	from 500 to 2000	120	180	120	90	127,5	150	90	20	10
KSB2	from 500 to 2000	120	180	120	90	110	150	90	15	15
KSB5	from 3000 to 5000	120	215	120	90	150	185	90	25	15



AVAILABLE ALSO IN ATEX CERTIFIED VERSION:
ATEX II 1G Ex ia IIC T6 (Ta -20÷+40°C) TX (Ta -20÷+65°C) Ga
ATEX II 1D Ex ta IIIC TX°C (Ta -20÷+40°C) TX°C (Ta -20÷+65°C) Da IP65

SBFI: ARTICULATED FOOT FOR HIGH RESOLUTION

Stainless steel articulated feet designed in order to obtain the best weighing performances, particularly suitable for creating scales with 4 load cells. Extremely compact and easy to install, the feet minimize the height of the platform and ensure a perfect decoupling of the lateral forces during the weighing operation.



INOX
AISI 304

- **COMPLETELY AISI304 STAINLESS STEEL CONSTRUCTION**
- **BUILT-IN NON-SLIP RUBBER**
- **FITTED WITH ANTI-VIBRATION GASKET**
- **EXTERNAL TREATMENT RESISTANT TO CORROSION**

Code	Max capacity (kg)
SBFI	from 500 to 2000
SBFI3K	from 3000 to 5000

PLX: CELL KITS FOR ASSEMBLING FLOOR SCALES

The kit is made up of four SBX load cells together with hypersanitizable adjustable mounting feet and a junction box with a built-in equalisation board. Suitable for creating various sizes and capacities scales, connectable to any type of weight indicator.



- | | |
|----------------------|--|
| Load cells | <ul style="list-style-type: none"> • 17-4PH stainless steel • C3 class • IP68 protection |
| Leveling feet | <ul style="list-style-type: none"> • stainless steel • adjustable height • anti-slip rubber |
| Junction box | <ul style="list-style-type: none"> • ABS • IP67 protection • 5 fairleads |

Code	Provided cell
PLX1K405C3	SBX500-1K
PLX1K410C3	SBX1000-1K
PLX1K420C3	SBX2000-1K

COMPRESSION LOAD CELLS FROM 250 TO 100.000 kg

CPX

Stainless steel load cells with IP68 protection classification, suitable for use in industrial environments.

✓ Ensure a high performance and an excellent resistance to great stress.

- ✓ Particularly suitable in the foodstuff and chemical industries, in industrial process and automation, for the weighing of tanks, hoppers, and silos.
- ✓ Quick and simple installation / replacement of the load cells thanks to the KCPN assembly kit.

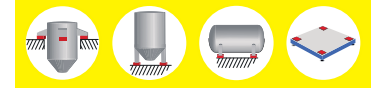

ATEX II 1G Ex ia IIC T6
(Ta -20/+40°C)
TX (Ta -20/+65°C) Ga
ATEX II 1D Ex ta IIIC TX°C
(Ta -20/+40°C)
TX°C (Ta -20/+65°C) Da IP65



TECHNICAL FEATURES

Accuracy class	C3
Protection classification	IP68
Construction	17-4 PH stainless steel
Combined error of Full Scale Output (F.S.)	0.2%
Full Scale Output	2mV/V ± 0.5%
Temperature effect on zero	0.02% / 10°C
Temperature effect on full scale output	0.02% / 10°C
Compensated Temperature	-10°C / +50°C
Operating Temperature	-20°C / +60°C
Creep error after 30 minutes	0.02% F.S
Maximum tolerated excitation voltage	10 Vdc
Input Resistance	750 ± 10 Ohm
Output Resistance	700 ± 5 Ohm
Insulation Resistance	>5000 MOhm
Safe Overload	120% F.S
4-wire shielded cable, Ø 5mm	<ul style="list-style-type: none"> • 5m (CPX250 ... 5000) • 10m (CPX7500 ... 100000)

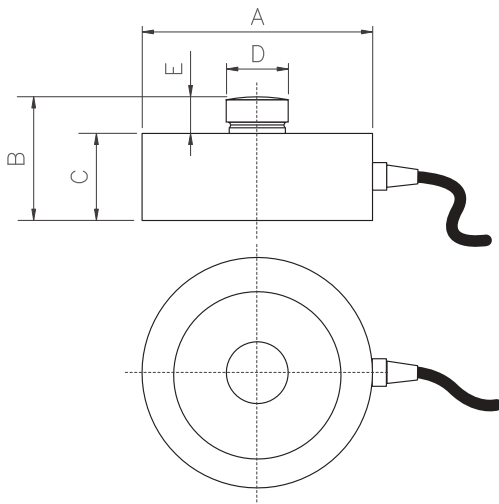

Code	Max capacity (kg)	Dimensions (mm)				
		A	B	C	D	E
CPX250 / 500 / 1000	250 / 500 / 1000	82	44	32	22	12
CPX2500 / 5000 / 7500 / 10000 / 12500	2500 / 5000 / 7500 / 12500	82	44	32	22	12
CPX15000	15000	100	47	35	28	12
CPX30000	30000	126	54	40	35	14
CPX50000	50000	165	80	60	60	20
CPX100000	100000	165	80	60	60	20

KCPN: ASSEMBLY KIT FOR COMPRESSION LOAD CELLS

Assembly kits for CPX series compression load cells, suitable for weighing silos, hoppers, horizontal or vertical tanks with a medium to large size or high-capacity weighing platforms.

- ✔ Designed to ensure the correct functioning of the load cell and to ensure the optimum weighing accuracy and high measure reliability over time.
- ✔ Simple installation / replacement of the load cells even when the kit is already installed.

- **CONSTRUCTION IN AISI304 STAINLESS STEEL**
- **GREAT RESISTANCE TO LATERAL FORCES**
- **OVERTURN-PROOF SCREW JACKS FOR EASY INSTALLMENT AND/OR SUBSTITUTION OF THE LOAD CELL**
- **SELF-CENTERING CONNECTION SEGMENT BETWEEN LOWER AND UPPER PLATES**





AVAILABLE ALSO IN ATEX CERTIFIED VERSION

ATEX II 1G Ex ia IIC T6
(Ta -20÷+40°C)
TX (Ta -20÷+65°C) Ga
ATEX II 1D Ex ta IIIC TX°C
(Ta -20÷+40°C)
TX°C (Ta -20÷+65°C) Da IP65

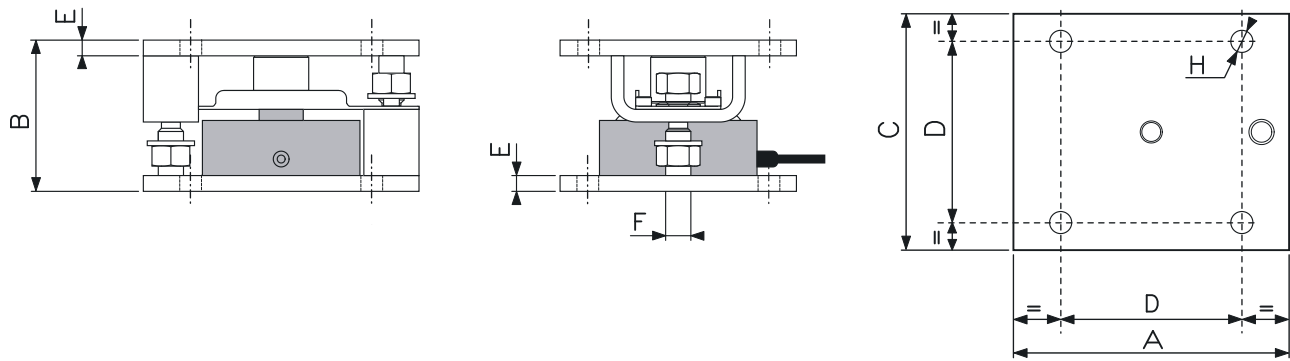

Code	Max capacity (kg)	Dimensions (mm)						
		A	B	C	D	E	F	H
KCPN10	from 250 to 10000	175	96	150	115	10	M16	Ø 14
KCPN15	15000	175	96	150	115	10	M16	Ø 14
KCPN30	30000	230	118	200	160	10	M20	Ø 17
KCPN100	from 50000 to 100000	320	154	320	250	15	M30	Ø 23

DOUBLE SHEAR BEAM LOAD CELLS FROM 10.000 TO 30.000 kg

DSBI

Stainless steel double shear beam load cells, extremely robust and resistant, with IP68 protection classification. Particularly suitable for creating CE-M approved 4-cell scales with high capacity,

and for weighing tanks, silos, and hoppers, thanks to the KDSBN assembly kit. They ensure a high accuracy even in case of expansion of the structure to be weighed.

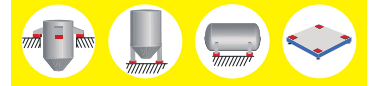

AVAILABLE ALSO
IN ATEX CERTIFIED
VERSION

ATEX II 1G Ex ia IIC T6
(Ta -20÷+40°C)
TX (Ta -20÷+65°C) Ga
ATEX II 1D Ex ta IIIC TX°C
(Ta -20÷+40°C)
TX°C (Ta -20÷+65°C) Da IP65



TECHNICAL FEATURES

Accuracy class	C4
Protection classification	IP68
Construction	17-4 PH stainless steel
Minimum load cell verification interval (Vmin)	EMax/10000
Combined error of Full Scale Output (F.S.)	0,03%
Full Scale Output	2mV/V ± 0,1%
Temperature effect on zero	0,00116% / °C
Temperature effect on full scale output	0,00097% / °C
Compensated Temperature	-10°C / +40°C
Operating Temperature	-30°C / +85°C
Creep error after 30 minutes	<0,02% F.S
Maximum tolerated excitation voltage	15 Vdc
Input Resistance	700 ± 7 Ohm
Output Resistance	700 ± 7 Ohm
Insulation Resistance	>5000 MOhm
Zero Balance	± 1%
Safe Overload	150% F.S
Ultimate Overload	300% F.S
6-wire shielded cable	15m

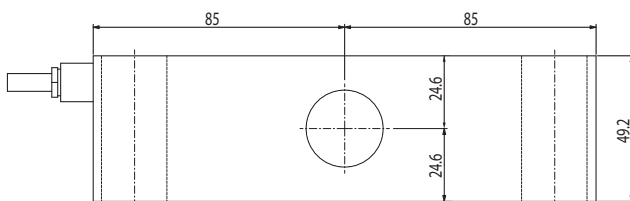
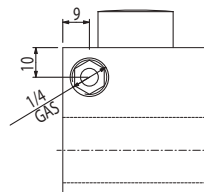
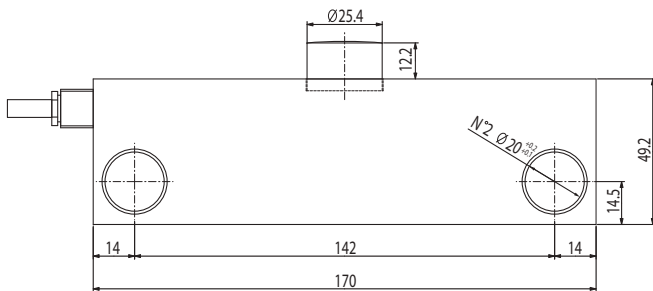

Code

Max capacity (kg)

DSBI10 / 20 / 30

10000 / 20000 / 30000

KDSBN: ASSEMBLY KIT FOR DOUBLE SHEAR BEAM LOAD CELLS

Assembly kits for DSBI series double shear beam load cells, suitable for weighing silos, hoppers, horizontal or vertical tanks with a large size or high-capacity weighing platforms.

- ✔ Ensure the correct functioning of the load cell.
- ✔ Guarantee excellent weighing accuracy and high measure reliability even in case of an expanded or bent structure to be weighed.

- **CONSTRUCTION IN AISI304 STAINLESS STEEL**
- **GREAT RESISTANCE TO LATERAL FORCES**
- **OVERTURN-PROOF SCREW JACKS FOR EASY INSTALLMENT AND/OR SUBSTITUTION OF THE LOAD CELL**
- **SELF-CENTERING CONNECTION SEGMENT BETWEEN LOWER AND UPPER PLATES**



AVAILABLE ALSO IN ATEX CERTIFIED VERSION

ATEX II 1G Ex ia IIC T6
(Ta -20÷+40°C)
TX (Ta -20÷+65°C) Ga
ATEX II 1D Ex ta IIIC TX°C
(Ta -20÷+40°C)
TX°C (Ta -20÷+65°C) Da IP65



INOX
AISI 304

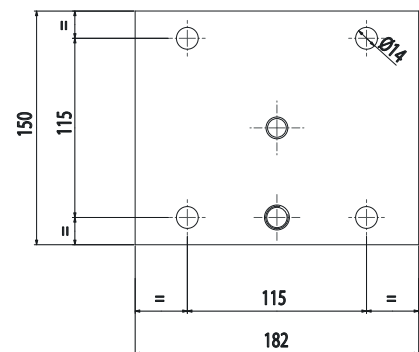
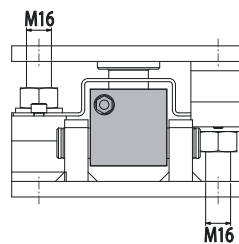
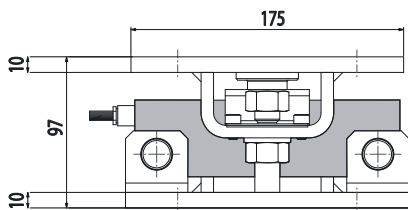

Code	Max capacity (kg)
KDSBN	up to 30000

BENDING BEAM LOAD CELLS FROM 10 TO 500 kg

FXC and FXD

Stainless steel bending beam load cells, with IP68 protection classification, suitable for using in industrial automations. Ideal for hoppers and mixers with small

and medium size and for the integration in the dosage systems, thanks to the KFXDN assembly kit.

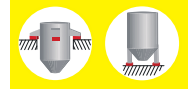

AVAILABLE ALSO
IN ATEX CERTIFIED
VERSION

ATEX II 1G Ex ia IIC T6
(Ta -20÷+40°C)
TX (Ta -20÷+65°C) Ga
ATEX II 1D Ex ta IIIC TX°C
(Ta -20÷+40°C)
TX°C (Ta -20÷+65°C) Da IP65

FXC

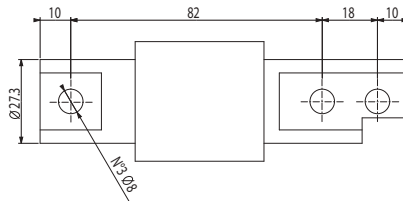
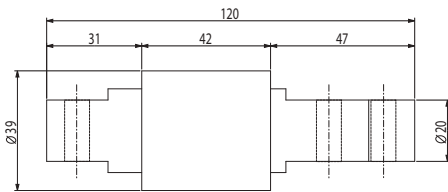

TECHNICAL FEATURES

	FXC	FXD
Accuracy class	C3	C3
Protection classification	IP68	IP68
Construction	stainless steel	stainless steel
Minimum load cell verification interval (Vmin)	EMax / 10000	EMax / 10000
Maximum number of verification intervals	nLC=3000	nLC=3000
Combined error of Full Scale Output (F.S.)	0,017%	0,017%
Full Scale Output	2mV/V ± 0,1%	2.0 ± 0,002mV/V
Non-Repeatability	± 0,015%	± 0,015%
Temperature effect on zero	0,002% / °C	± 0,02% F.S./10°C
Temperature effect on full scale output	0,0012% / °C	± 0,02% F.S./10°C
Compensated Temperature	-10°C / +40°C	-10°C / +40°C
Operating Temperature	-20°C / +60°C	-30°C / +70°C
Creep error after 30 minutes	0,016% F.S.	0,016% F.S.
Maximum tolerated excitation voltage	15 Vdc	15 Vdc
Input Resistance	385 ± 20 Ohm	400 ± 20 Ohm
Output Resistance	350 ± 5 Ohm	352 ± 3 Ohm
Insulation Resistance	>5000 MOhm	>5000 MOhm
Safe Overload	200% F.S.	120% F.S.
Ultimate Overload	300% F.S.	150% F.S.
Nominal displacement	<0,4mm	<0,4mm
4-wire shielded cable	3m, Ø 4mm	3m, Ø 5mm

FXD

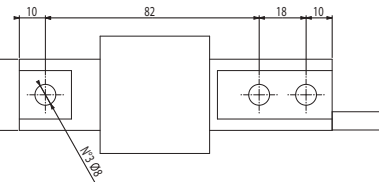
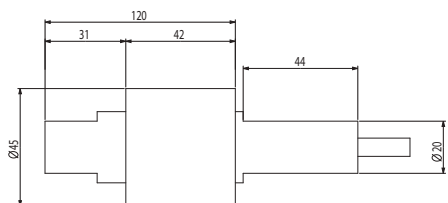

Code	Max capacity (kg)
FXC10 / 20 / 50 / 100 / 200 / 300 / 500	10 / 20 / 50 / 100 / 200 / 300 / 500

Code	Max capacity (kg)
FXD100 / 200 / 300 / 500	100 / 200 / 300 / 500

KFXDN: ASSEMBLY KIT FOR BENDING BEAM LOAD CELLS

Assembly kits for FXC and FXD series bending beam load cells, suitable for weighing hoppers, mixers, and tanks with small or medium size.

- ✔ Designed to ensure the correct functioning of the load cell.
- ✔ Ensure optimum weighing accuracy, thanks to the articulated joint which guarantees the vibration damping and the compensation of the thermal expansion of the structure to be weighed.

- **CONSTRUCTION IN STAINLESS STEEL**
- **SAFETY LOCK FOR THE TRANSPORT**
- **FITTED WITH AN ARTICULATED JOINT FOR VIBRATIONS ABSORPTION AND EXPANSIONS COMPENSATION**

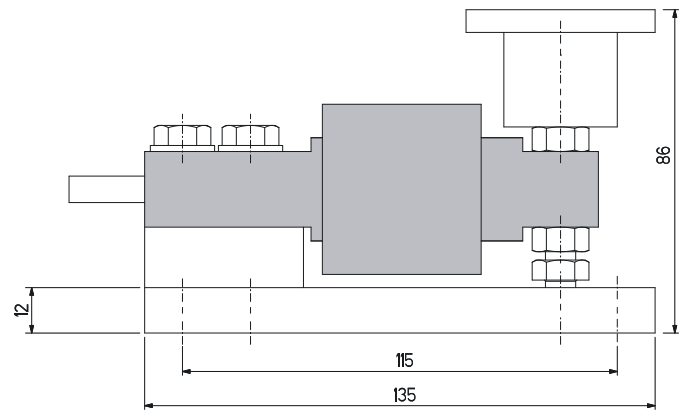

Suitable for **weigh hoppers**.

EX
 AVAILABLE ALSO
 IN ATEX CERTIFIED
 VERSION

ATEX II 1G Ex ia IIC T6
 (Ta -20÷+40°C)
 TX (Ta -20÷+65°C) Ga
 ATEX II 1D Ex ta IIIC TX°C
 (Ta -20÷+40°C)
 TX°C (Ta -20÷+65°C) Da IP65

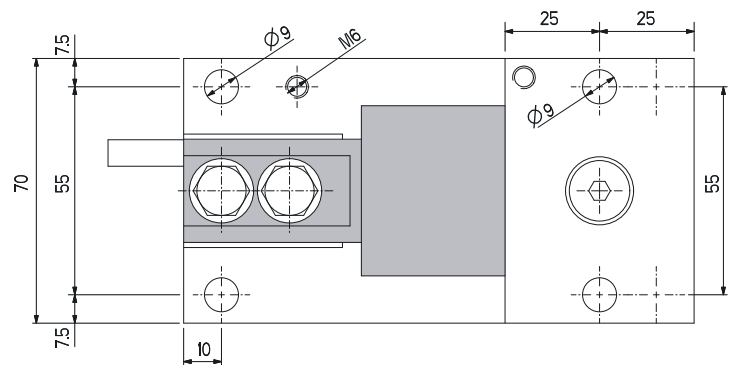

Code	Max capacity (kg)
KFXDN	up to 500

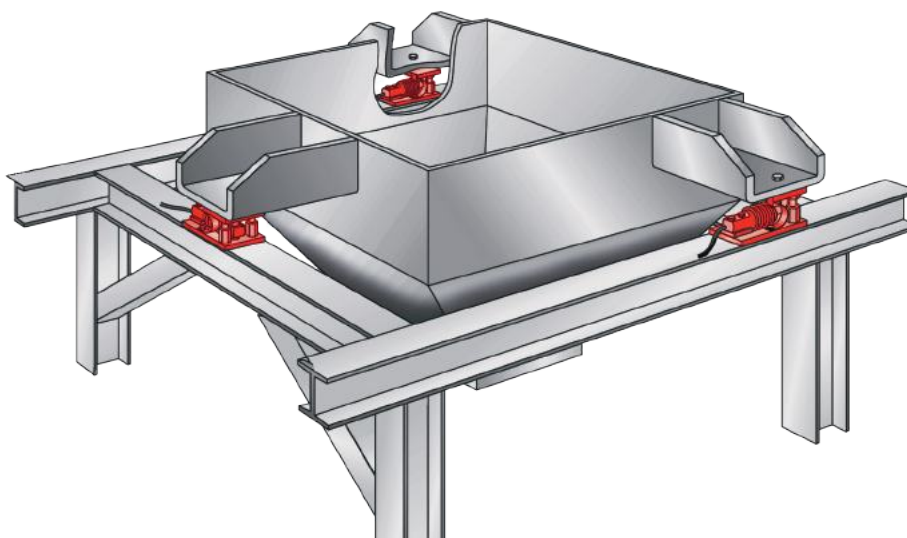

ALUMINIUM SINGLE POINT LOAD CELLS

FROM 3 TO 750 kg



SP

Single point load cells suitable to build CE-M approved scales with a single load cell. Guarantee high weighing accuracy thanks to the off-center loads compensation.



ATEX II 1G Ex ia IIC T6
(Ta -20÷+40°C)
TX (Ta -20÷+65°C) Ga
ATEX II 1D Ex ta IIIC TX°C
(Ta -20÷+40°C)
TX°C (Ta -20÷+65°C) Da IP65

TECHNICAL FEATURES

	SPO	SPG	SPG	SPM	SPN
Accuracy class	C3	C3	C6	C3	C3
Protection classification	IP67	IP67	IP67	IP67	IP67
Minimum load cell verification interval (Vmin)	EMax / 15.000	EMax / 15.000	EMax / 20.000	EMax / 15.000	EMax / 15.000
Full Scale Output	2mV/V +/- 10%	2mV/V +/- 10%	2mV/V +/- 10%	2mV/V +/- 10%	2mV/V +/- 10%
Temperature effect on zero	0,01% F.S./10K	0,01% F.S./10K	0,01% F.S./10K	0,01% F.S./10K	0,01% F.S./10K
Temperature effect on full scale output	0,001% F.S./10K	0,001% F.S./10K	0,001% F.S./10K	0,001% F.S./10K	0,001% F.S./10K
Compensated Temperature	-10°C/+40°C	-10°C/+40°C	-10°C/+40°C	-10°C/+40°C	-10°C/+40°C
Operating Temperature	-10°C/+50°C	-10°C/+50°C	-10°C/+50°C	-10°C/+50°C	-10°C/+50°C
Creep error after 30 min.	0,01% F.S.	0,01% F.S.	0,01% F.S.	0,01% F.S.	0,01% F.S.
Maximum tolerated excitation voltage	15 Vdc	15 Vdc	15 Vdc	15 Vdc	15 Vdc
Input Resistance	300..500 Ohm	300..500 Ohm	300..500 Ohm	300..500 Ohm	300..500 Ohm
Output Resistance	300..500 Ohm	300..500 Ohm	300..500 Ohm	300..500 Ohm	300..500 Ohm
Insulation Resistance	>2000 MOhm	>2000 MOhm	>2000 MOhm	>2000 MOhm	>2000 MOhm
Safe Overload	150% F.S.	150% F.S.	150% F.S.	150% F.S.	150% F.S.
Ultimate Overload	300% F.S.	300% F.S.	300% F.S.	300% F.S.	300% F.S.
Nominal displacement	< 0,5 mm	<0,3mm	<0,3mm	< 0,5 mm	< 0,5 mm
Shielded cable	40cm, Ø 3.2mm / 4-wire	3m, Ø 4.7mm / 6-wire	3m, Ø 4.7mm / 6-wire	3m, Ø 5mm / 6-wire	3m, Ø 5mm / 6-wire

The values of temperature effects in the table are indicative, the sum of these errors (including hysteresis and linearity) remain within the limit of the errors sum, according to OIML R60.

SPO



Code	Capacity (kg)	Platform l x w max. (mm)
SPO3	3	150 x 150
SPO5	5	300 x 300
SPO10	10	300 x 300
SPO15	15	300 x 300
SPO20	20	300 x 300
SPO30	30	300 x 300

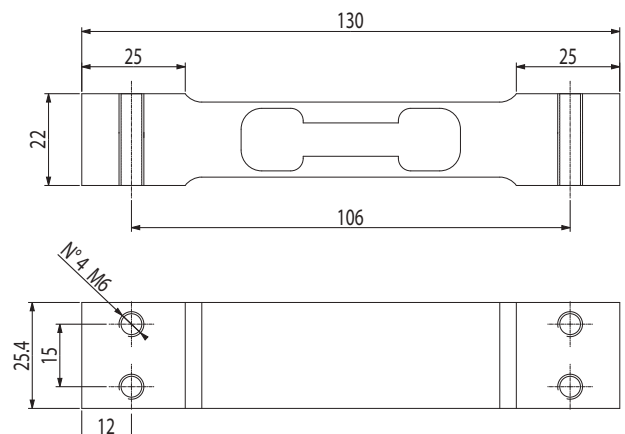

SPG

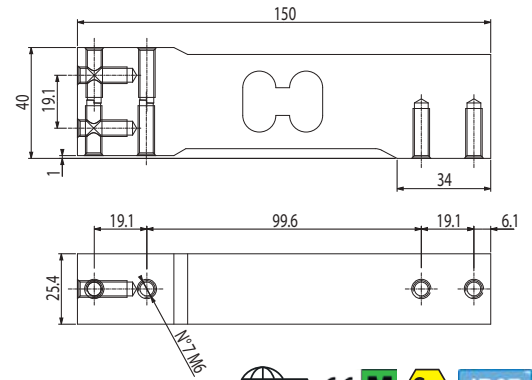

Versions in C3 class

Code	Capacity (kg)	Platform l x w max. (mm)
SPG10	10	300 x 300
SPG15	15	400 x 400
SPG20	20	450 x 450
SPG30	30	450 x 450
SPG50	50	600 x 600
SPG100	100	600 x 600
SPG200	200	600 x 600

Versions in C6 class

Code	Capacity (kg)	Platform l x w max. (mm)
SPG7C6	7	300 x 300
SPG18C6	18	400 x 400
SPG36C6	36	450 x 450

SPM

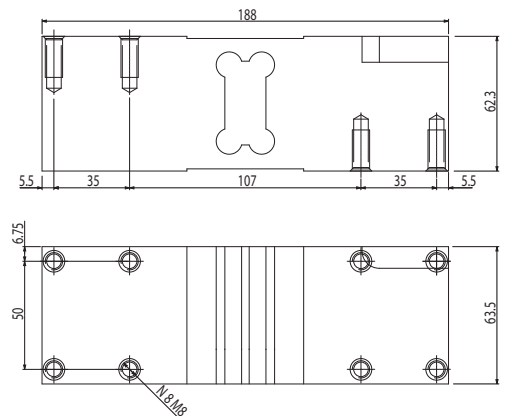
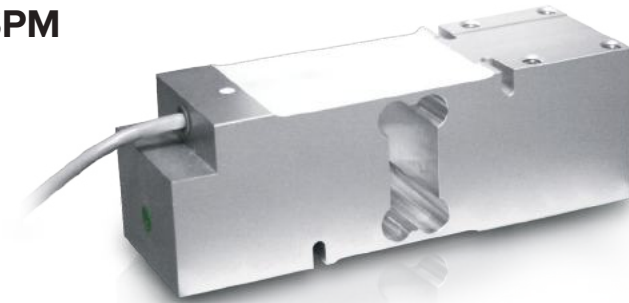

Code	Capacity (kg)	Platform l x w max. (mm)
SPM100	100	600 x 600
SPM200	200	600 x 600
SPM500	500	600 x 600

SPN

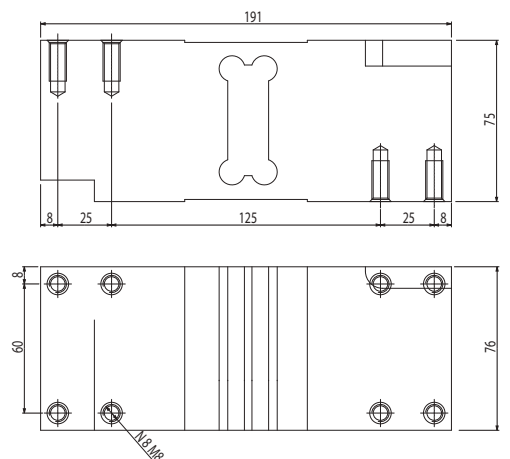

Code	Capacity (kg)	Platform l x w max. (mm)
SPN300	300	800 x 800
SPN500	500	800 x 800
SPN750	750	800 x 800

STAINLESS STEEL SINGLE POINT LOAD CELLS

FROM 7.5 TO 1000 kg



SPS

Single point load cells suitable to build CE-M approved scales with a single load cell. Guarantee high weighing accuracy thanks to the off-center loads compensation.



ATEX II 1G Ex ia IIC T6
(Ta -20÷+40°C)
TX (Ta -20÷+65°C) Ga
ATEX II 1D Ex ta IIIC TX°C
(Ta -20÷+40°C)
TX°C (Ta -20÷+65°C) Da IP65

TECHNICAL FEATURES

	SPSW	SPSY	SPSX	SPSZ
Accuracy class	C3	C3	C3	C3
Protection classification	IP67	IP68	IP67	IP68
Minimum load cell verification interval (Vmin)	EMax / 10.000	EMax / 10.000	EMax / 15.000	EMax / 10.000
Full Scale Output	2mV/V +/- 0,2%	2mV/V +/- 10%	2mV/V +/- 10%	2mV/V +/- 10%
Temperature effect on zero	0,01% F.S./10K	0,01% F.S./10K	0,01% F.S./10K	0,01% F.S./10K
Temperature effect on full scale output	0,001% F.S./10K	0,001% F.S./10K	0,001% F.S./10K	0,001% F.S./10K
Compensated Temperature	-10°C/+40°C	-10°C/+40°C	-10°C/+40°C	-10°C/+40°C
Operating Temperature	-10°C/+50°C	-10°C/+50°C	-10°C/+50°C	-10°C/+50°C
Creep error	after 30 minutes ± 0,01% F.S.	after 30 minutes ± 0,01% F.S.	after 30 minutes ± 0,01% F.S.	after 30 minutes ± 0,01% F.S.
Maximum tolerated excitation voltage	15 Vdc	15 Vdc	15 Vdc	15 Vdc
Input Resistance	380 ± 15 Ohm	380 ± 15 Ohm	390 ± 15 Ohm	380 ± 15 Ohm
Output Resistance	359 ± 5 Ohm	350 ± 10 Ohm	359 ± 5 Ohm	350 ± 10 Ohm
Insulation Resistance (100V)	>1000 MOhm	>2000 MOhm	>1000 MOhm	>2000 MOhm
Safe Overload	300% F.S.	300% F.S.	300% F.S.	300% F.S.
Ultimate Overload	300% F.S.	300% F.S.	300% F.S.	300% F.S.
Nominal displacement	< 0,5 mm	< 0,5 mm	< 0,5 mm	< 0,5 mm
Shielded cable	3m, Ø 5mm / 6-wire	3m, Ø 5mm / 6-wire	3m, Ø 5mm / 6-wire	3m, Ø 5mm / 6-wire

The values of temperature effects in the table are indicative, the sum of these errors (including hysteresis and linearity) remain within the limit of the errors sum, according to OIML R60.

SPSW



Code	Max capacity (kg)	Platform l x w max. (mm)
SPSW7.5	7,5	500 x 400
SPSW15	15	500 x 400
SPSW30	30	500 x 400
SPSW50	50	500 x 400
SPSW100	100	500 x 400

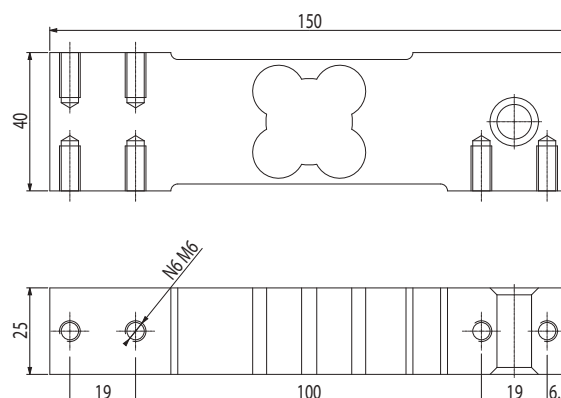

SPSY



Code	Max capacity (kg)	Platform l x w max. (mm)
SPSY50	50	500 x 400
SPSY100	100	500 x 400

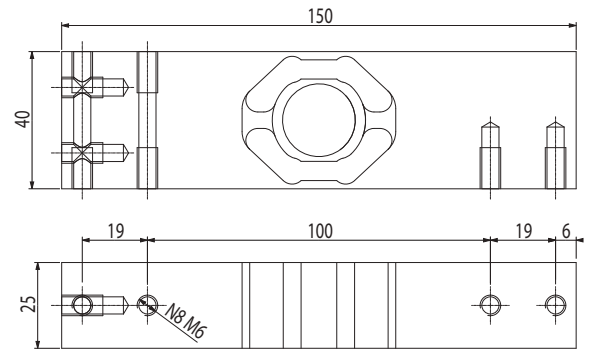

SPSX

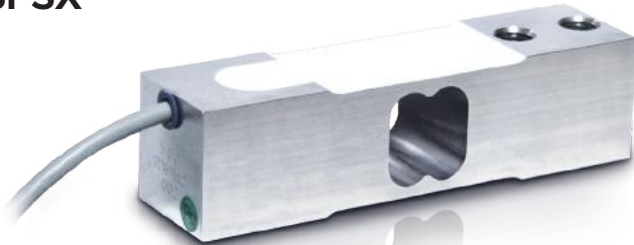

Code	Max capacity (kg)	Dimensions (mm)		Platform l x w max. (mm)
		A		
SPSX300	300	M10		600 x 800
SPSX500	500	M12		600 x 800

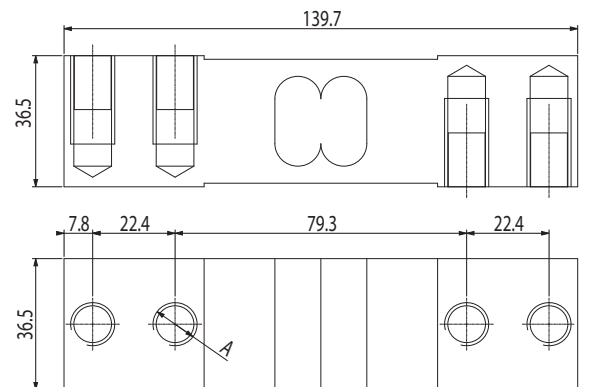

SPSZ



Code	Max capacity (kg)	Platform l x w max. (mm)
SPSZ500	500	800 x 800
SPSZ1000	1000	800 x 800

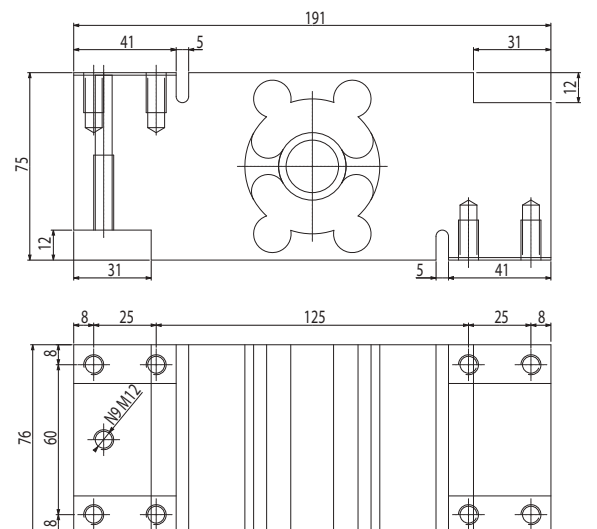

TENSION LOAD CELLS FROM 100 TO 10.000 kg

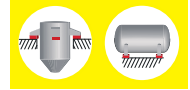

STG and STFC

Tension load cells, fitted with robust structure and IP67 protection classification, particularly suitable for using in industrial environments.

Ideal for weighing suspended loads, hoppers, tanks, and lever scales, thanks to the KST kits.



ATEX II 1G Ex ia IIC T6
(Ta -20÷+40°C)
TX (Ta -20÷+65°C) Ga
ATEX II 1D Ex ta IIIC TX°C
(Ta -20÷+40°C)
TX°C (Ta -20÷+65°C) Da IP65

STG



CE M Ex IP67 INOX

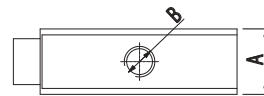
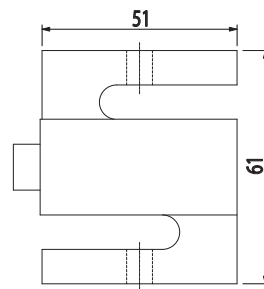

STFC



CE M Ex IP67

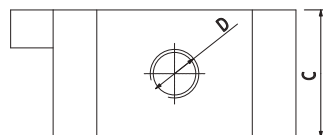
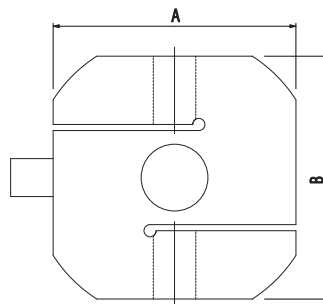

TECHNICAL FEATURES

	STG	STFC
Accuracy class	C3	C3
Protection classification	IP67	IP67
Construction	stainless steel	Nickel-plated steel
Minimum load cell verification interval (Vmin)	•EMax / 7.000 (STG100 version) •EMax / 10.000 (STG500 & STG1000 version)	EMax / 10000
Maximum number of verification intervals	nLC=3000	nLC=3000
Combined error of Full Scale Output (F.S.)	0,02%	0,02%
Full Scale Output	3mV/V ± 0,08%	2mV/V ± 0,1%
Non-Repeatability	0,017% / °C	0,0013% / °C
Temperature effect on zero	0,014% / °C	0,0014% / °C
Temperature effect on full scale output	-10°C / +40°C	-10°C / +40°C
Compensated Temperature	-35°C / +65°C	-20°C / +60°C
Operating Temperature	after 30 minutes 0,02% F.S.	after 4 hours 0,03% F.S.
Creep error after 30 minutes	18 Vdc	10 Vdc
Maximum tolerated excitation voltage	430 ± 60 Ohm	1100 Ohm
Input Resistance	350 ± 3.5 Ohm	1000 Ohm
Output Resistance	>5000 MOhm	>5000 MOhm
Insulation Resistance	±1% F.S.	±1% F.S.
Safe Overload	150% F.S.	130% F.S.
Ultimate Overload	300% F.S.	300% F.S.
4-wire shielded cable	6m, Ø 5mm	5m, Ø 5mm

Code	Max capacity (kg)	Dimensions (mm)	
		A	B
STG100	100	15	M8
STG500	500	21	M12
STG1000	1000	28	M12

Code	Max capacity (kg)	Dimensions (mm)			
		A	B	C	D
STFC2000	2000	80	80	42	M16
STFC5000	5000	80	80	42	M24x2
STFC10000	10000	80	80	52	M24x2

KST: JOINTS FOR TENSION LOAD CELLS

Articulated joint kits for STG and STFC series tension load cells, suitable for suspended loads weighing.

- ✓ Installed at the two ends of the cell, the joints assure the correct functioning in accordance with the directives for the cells installation.
- ✓ Ensure optimum weighing accuracy and high measure reliability with static tension forces.

Ex
AVAILABLE ALSO IN ATEX CERTIFIED VERSION

ATEX II 1G Ex ia IIC T6
(Ta -20÷+40°C)
TX (Ta -20÷+65°C) Ga
ATEX II 1D Ex ta IIIC TX°C
(Ta -20÷+40°C)
TX°C (Ta -20÷+65°C) Da IP65



RBJ

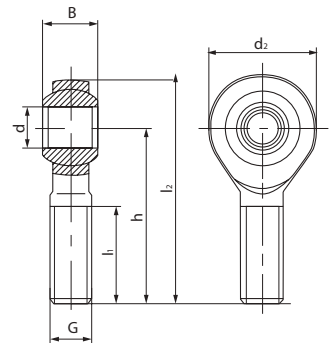

Code	Dimensions (mm)						
	d	G H6	l ₁ min	d ₂	h	l ₂	B
RBJM8	8	M8x1,25	22	24	42	54	8
RBJM12	12	M12x1,75	28	34	54	71	10
RBJM16	17	M16x2,0	36	46	69	92	14
RBJM24	25	M24x2,0	53	64	94	126	20

CLV

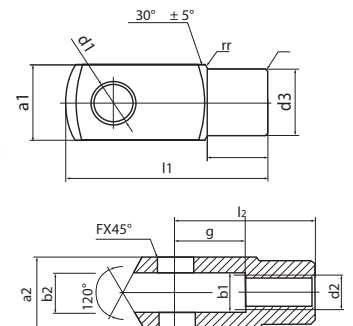

Code	Dimensions (mm)									
	d ₁ H9	g	a ₁	a ₂	b ₁	d ₂	d ₃	l ₁	l ₂	l ₂ var. max
CLVM8	8	161	16	16	8	M8x1,25	14	42	32	0,4
CLVM12	12	24	24	24	12	M12x1,75	20	62	48	0,4
CLVM16	17	32	32	32	12	M16x2,0	26	83	64	0,4
CLVM24	25	50	50	50	25	M24x2,0	42	132	100	0,4

Code	Max capacity (kg)
RBJM8	600
RBJM12	1.000
RBJM16	2.000
RBJM24	5.000

JUNCTION BOXES

JB

The junction boxes have an important role in the configuration of multi-load cell systems. The ABS or stainless steel cases are both designed for use in the presence of water and dust, offering different protection

degrees according to the model. The junction and equalization electronic boards are fitted with screw terminals for an easy connection of cells, and a signal regulation trimmer for an accurate and

reliable equalization. In the version with 10 inputs, the card is also fitted with a protection system against overloads and shocks.

SCHEME OF USE

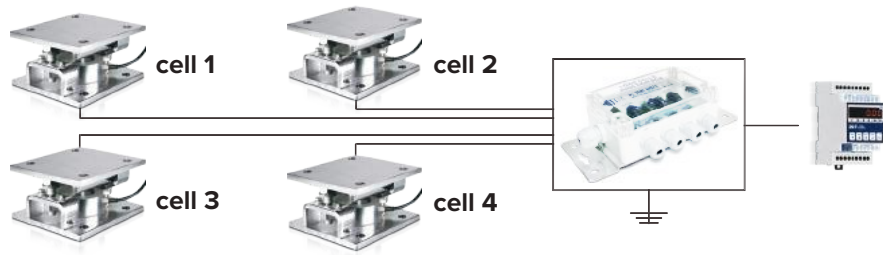

JBQ



IP67



Available also in ATEX version

Case	ABS
Protection classification	IP67
Maximum input voltage	24 Vdc
Maximum input current	700 mA
Maximum input load cell signal	1000 mV

JB10Q



IP68

Case	Polyester
Protection classification	IP68
Maximum input voltage	24 Vdc
Maximum input current	700 mA
Maximum input load cell signal	1000 mV

JBQI



INOX

IP65



Available also in ATEX version

Case	Stainless steel
Protection classification	IP65
Maximum input voltage	24 Vdc
Maximum input current	700 mA
Maximum input load cell signal	1000 mV

Code	Dimensions (mm)		
	A	B	C
JB2Q	80	120	55
JB3Q	80	120	55
JB4Q	80	120	55
JB4QI	155	158	45
JB6QI	132	190	50
JB10Q	120	220	90
JB1QAI	130	190	45
JB2QAI	130	190	45
JB3QAI	130	190	45
JB4QAI	130	190	45

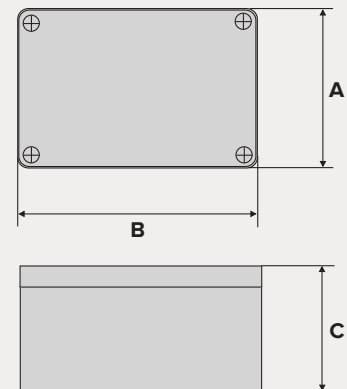

INSTALLATION TIPS

The surface under the load cells must be rigid and stable. The absence of linearity may be compensated through the use of the appropriate mounting kits.

These accessories are suitable for weighing hoppers, tanks, and silos, also suspended inside bearing structures.

SUSPENDED HOPPERS / TANKS

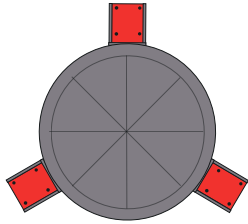

Cells positioned at 120°

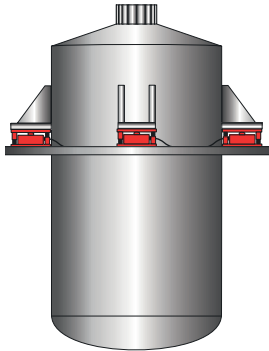
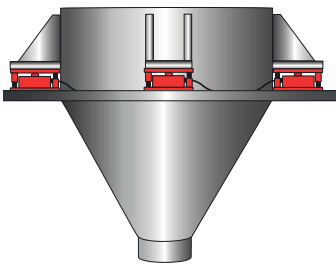
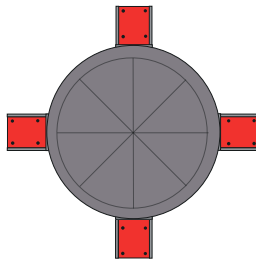

MEDIUM / LARGE SIZE SILOS

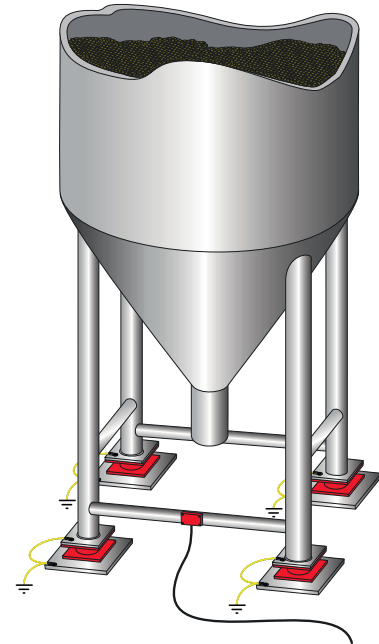

HORIZONTAL TANKS

In case of large-size horizontal tanks containing liquid, which can be particularly affected by expansion of the structure, a

cheaper system to weigh the content with a precision around 1% is to install two load cells on one side and two false cells or

joints on the other, in order to compensate the movement of the structure.

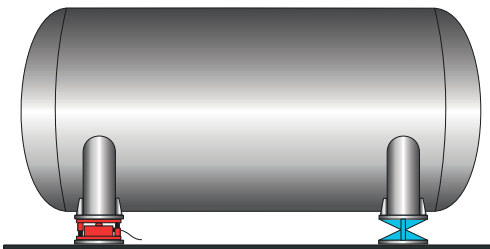

To complete a correct installation of the tank it must be:

- symmetrical in comparison to the line which crosses the center of gravity of the content;
- perfectly in level;
- not subject to the wind forces.

In this way one can ensure the best condition for the weighing.

NOTES ABOUT THE SYSTEM INCLINATION

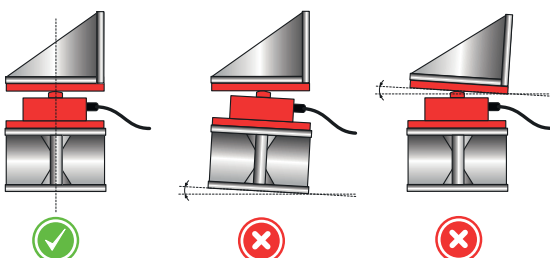

For a correct functioning of the weighing system and to obtain the best accuracy:

- The upper and lower plate of the kit must be perfectly flat and aligned with each other.
- The center of the surface imposed on the kit (for example the center of the foot of a silo) must match with the center of the upper plate of the kit.

GROUNDING THE WEIGHING SYSTEM

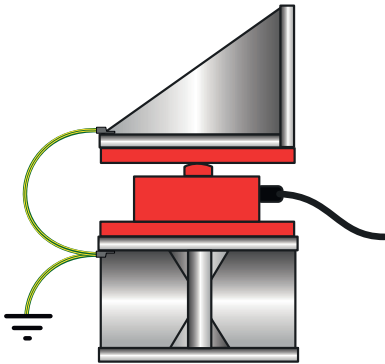

The grounding of the structure is indispensable to guarantee an optimum protection of the load cells from electrostatic discharge. A bridge between the upper plate and the lower plate of the kit is necessary and it could be created by using a cable or a copper braid of appropriate diameter.

The failure of this assembly may not immediately affect the functioning of the system, but it can cause failure, even irreversible, of all the load cells and the attached weight indicator.

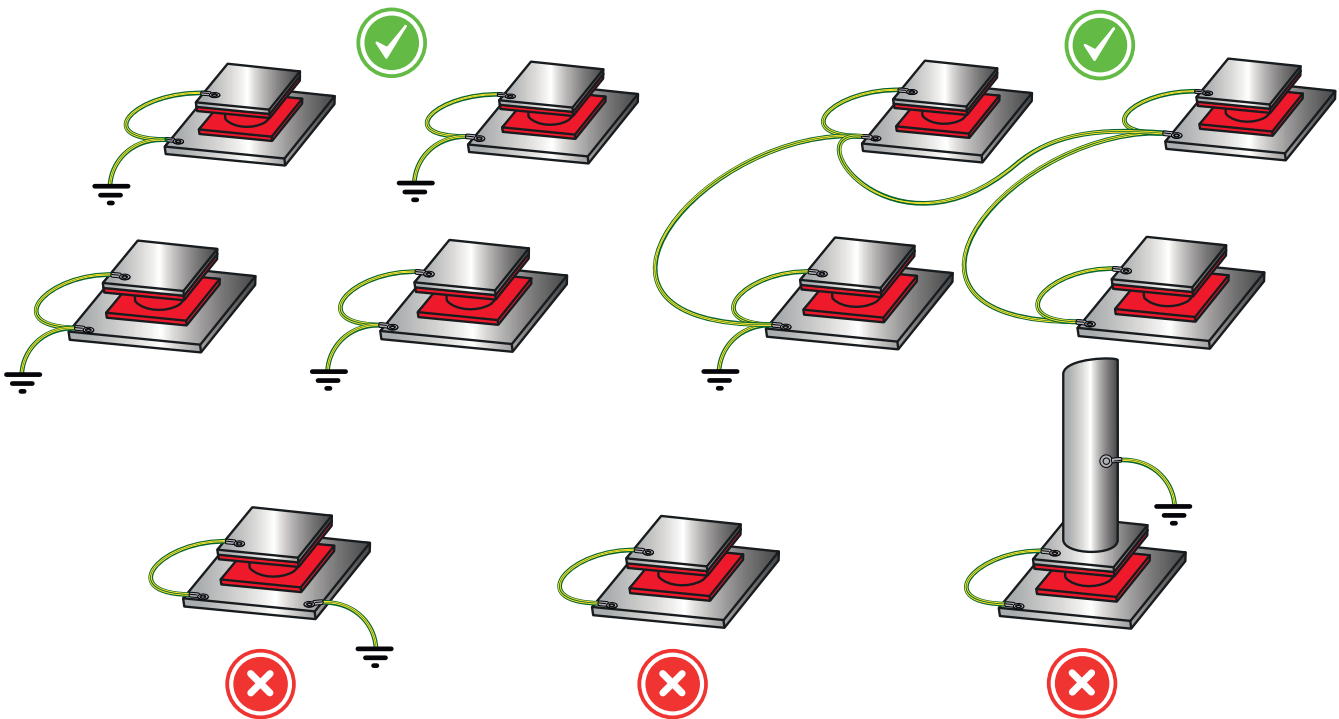

NOTES ABOUT THE BEARING STRUCTURE

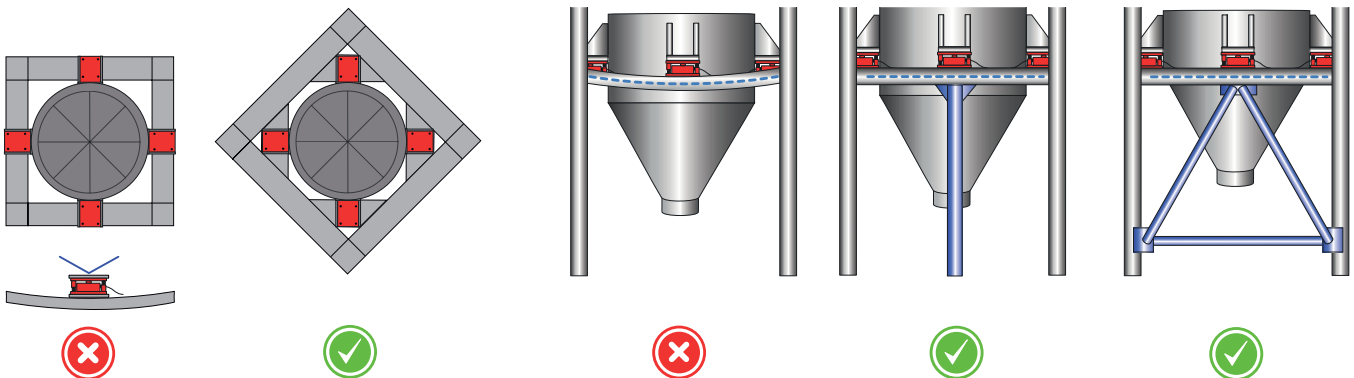

It is necessary to study with great attention the placement of the load cells and the mechanical features of the structure, avoiding any irregular

bending and deformation. The support surface, on where the kit will be installed, must be rigid and stable. If during the use of the system any bending

or abnormal deformations are noted, it will be appropriate to reinforce the system by applying supports, tie rods, etc.

“YOUR WORLDWIDE PARTNER FOR WEIGHING”



A RICE LAKE WEIGHING SYSTEMS COMPANY

COMPANY HEADQUARTERS

Via Della Fisica, 20
41042 Spezzano di Fiorano - Modena - Italy
Tel. +39.0536 843418

SERVICE ASSISTANCE

Via Dell'Elettronica, 15
41042 Spezzano di Fiorano - Modena - Italy
Tel. +39.0536 921784

OTHER DINI ARGEO LOCATIONS

DINI ARGEO WEIGHING INSTRUMENTS Ltd
China

DINI ARGEO UK Ltd
United Kingdom

DINI ARGEO FRANCE sarl
France

DINI ARGEO GMBH
Germany

WHY CHOOSE DINI ARGEO?



WORLDWIDE SERVICE AND SHIPPING

International group with offices in America, Europe, India, China, Mexico and Oceania, over 900 employees and a network of specialised partners in 130 countries worldwide.



FAST SHIPPING

Dini Argeo always keeps complete systems in stock that can be shipped quickly.



MADE IN ITALY

Dini Argeo weighing solutions are made in Italy and guarantee the highest quality standards.

SALES SERVICE AND TECHNICAL ASSISTANCE

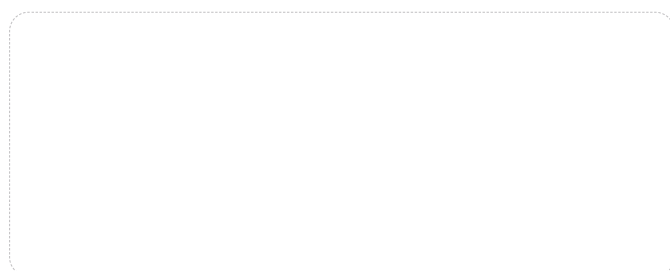

Mod **AUTDOS-CEN**

P/N 
AUTDOS-CEN

Sn 
NOSN

AUTDOS-CEN/NOSN

Rev. 01.03.2023