



**LOAD CELLS
& WEIGHT TRANSMITTERS**

CATALOGUE

 **DINI AR GEO**
Scales - Weighing systems

A RICE LAKE WEIGHING SYSTEMS COMPANY

		Capacity (kg)	Max load surface (mm)	Stainless Steel	ATEX	IP68	IP69K	Digital	Accuracy	Code		
OFF-CENTER		3 ... 40	300 x 300		•				C3	SPO	p.	6
		3 ... 75	350 x 350							SPD	p.	7
		10 ... 200	600 x 600		•				C3	SPG	p.	8
		7 ... 36	450 x 450		•				<u>C6</u>	SPG C6	p.	9
		100 ... 500	600 x 600		•				C3	SPM	p.	10
		100 ... 630	700 x 700		•				C3	SPBC	p.	11
		300 ... 750	800 x 800		•				C3	SPN	p.	12
		7.5 ... 200	500 x 400	•		•	•		C3	SPSW	p.	13
		50 ... 100	500 x 400	•	•				C3	SPSY	p.	14
		100 ... 500	800 x 800	•					C3	SPSX	p.	15
		500 ... 1000	800 x 800	•	•	•			C3	SPSZ	p.	16
BENDING BEAM		10 ... 500		•	•	•			C3	FXC	p.	18
		20 ... 200		•		•			<u>C6</u>	FXC C6	p.	20
		10 ... 500		•	•	•			C3	FXD	p.	22
		MOUNTING KITS									p.	24
SHEAR BEAM		500 ... 2000			•				C3	SBT	p.	28
		500 ... 10 t		•	•	•			C3	SBX	p.	30
		500 ... 2000		•	•	•			<u>C6</u>	SBK C6	p.	32
		MOUNTING KITS									p.	34
DOUBLE SHEAR BEAM		25 t ... 40 t			•	•			C3	RSBT	p.	40
		10 t ... 30 t		•	•	•			<u>C4</u>	DSBI	p.	41
		MOUNTING KITS									p.	42
TENSION		2000 ... 10 t		•		•			C3	STU 1K	p.	44
		2000 ... 10 t			•				C3	STFC	p.	46
		15 ... 1000							C3	SL	p.	48
COMPRESSION		250 ... 100 t		•	•	•			C3	CPX	p.	50
		150 ... 500 t		•	•	•			C3	CPA	p.	52
		50 t ... 1000 t		•						CPH	p.	54
		MOUNTING KITS									p.	56
COLUMIN		30 t		•	•	•			<u>C4</u>	RCA	p.	64
		20 t ... 50 t		•			•		<u>C6</u>	RL5426 PLUS	p.	65
		20 t ... 50 t		•			•		<u>C4</u>	RL5416	p.	66
		20 t ... 50 t		•	•	•			C3	RCPT	p.	67
		30 t ... 50 t		•		•		•	<u>C4</u>	RCD	p.	68
		30 t ... 40 t		•		•		•	<u>C6</u>	RL5426DC	p.	69
		30 t ... 40 t		•		•		•	<u>C4</u>	RL5416DC	p.	70
		30 t		•		•		•	<u>C4</u>	RCPTD	p.	71
MOUNTING KITS									p.	72		
LOAD PINS		FULLY CUSTOMIZED								p.	74	
OTHER	JUNCTION BOXES										p.	76
	ZENER BARRIERS										p.	78
	CABLES										p.	79

INTERFACES AND PROTOCOLS



	Conversion rate (Hz)	N. of scales/channels	Digital load cells	Analog output	RS485 Modbus RTU	PROFINET	PROFIBUS	EtherNet/IP	Modbus TCP/IP	EtherCAT	CANopen	DeviceNet	Inputs / triggers	Outputs / setpoint		
p. 86	4800	1		●	●	●	○	●	●	●	○	○	2	4		DGT15X for DIN rail
p. 88	4800	1			●								2	4		DGT8X CHECK for DIN rail
p. 90	2600	Up to 4		●	●	●	●	●	●	●	●	●	2	2		DGT4X for DIN rail
p. 92	2600	Up to 4	●	●	●	●							2	2		DGT4X DIGITAL for DIN rail
p. 94	2600	Up to 4		●	●	●	●	●	●	●	●	●	2	2		DGT4XBD
p. 100	400	Up to 1		●	●	●	○	●	●	●	○	○	2	4		DGT5 PLUS for DIN rail
p. 102	400	1		●	●	○	○	○	○	○	○	○	2	2		DGT1S for DIN rail
p. 104	400	1		●	●		○						2	2		DGT1 for DIN rail
p. 106	400	Up to 4		●	●	●	●	●	●	●	○	○	2	2		DGT14 for DIN rail
p. 108	400			●	●								2	6		DGT1P panel mounting
p. 110	400	1		●	●		●						2	6		DGTTP panel mounting
p. 112	400	1		●	●		●						2	6		DGTQ panel mounting
p. 114	400	1		●	●	●							2	2		DGT20 for bench/wall
p. 116	400	1		●	●		●						2	2		DGT20I for bench/wall
p. 118	400	4		●	●								2	2		DGT100

● As standard ○ Special version, ask for estimate



A RICE LAKE WEIGHING SYSTEMS COMPANY



LOAD CELL AND WEIGHT TRANSMITTER MANUFACTURER

Dini Argeo designs and manufactures load cells and weighing sensors that stand out for their high quality and ease of installation. Through its production lines and highly qualified specialized partners, Dini Argeo is able to produce load cells of every type and for every need, from precision weighing to safety control.

This catalogue contains a complete range of load cells with standard dimensions and capacities, designed by Dini Argeo to suit most weighing applications. Dini Argeo also offers a design and development service for special load cells, please contact our sales department for more information.



For over 20 years Dini Argeo has been producing weight transmitters of the DGT series that stand out for their reliability and reading accuracy in automated industrial weighing systems.

DGT transmitters are manufactured and designed in Italy by Dini Argeo and feature all the latest technologies available on the market.

Thanks to its team of highly qualified engineers, Dini Argeo is also able to develop fully customised, certified weighing electronics and firmware in compliance with international standards.

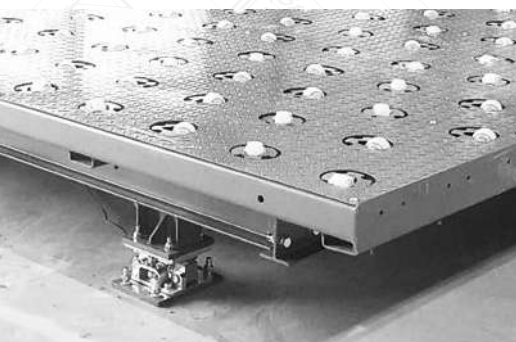

OFF-CENTER



Dini Argeo Off-Center/Single Point load cells are ideal for creating weighing areas with optimal measurement accuracy in any point. They are the best solution to create micro dispensers, weighing platforms, plates and belts at competitive prices. Thanks to their mechanical features, Off-Center load cells are particularly reactive and suitable for fast and dynamic weighing. They can be used both individually (single load cell systems) and in connection (systems with multiple load cells).

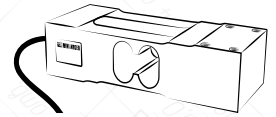

BENDING BEAM



Dini Argeo Bending Beam load cells combine the reactivity and accuracy of Off-Center/Single Point load cells with the strength of Shear Beam ones. The secret to achieving optimum accuracy with Bending Beam load cells is to apply the force in a specific point; for state-of-the-art installations, both in static and dynamic applications, Dini Argeo offers a complete range of mounting accessories. They are the best solution to create weighing roller conveyors. Ideal for systems with multiple load cells.

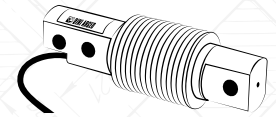

SHEAR BEAM



Dini Argeo Shear Beam load cells are the ideal solution to weigh medium capacity silos and hoppers and to create systems with multiple load cells, such as floor platforms. The secret to achieve optimum accuracy with Shear Beam load cells is to apply the force in a specific point; for state-of-the-art installations, both in static and dynamic applications, Dini Argeo offers a complete range of mounting accessories. Ideal for systems with multiple load cells.

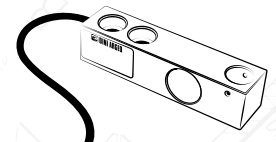

DOUBLE SHEAR BEAM



Dini Argeo Double Shear Beam load cells have the same features as Shear beam load cells but with much higher load capacities. They find application in large capacity silo weighing and are the best choice for the construction of weighbridges. Ideal for systems with multiple load cells.

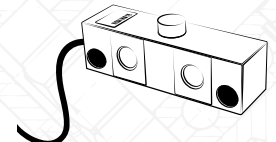

TENSION



Dini Argeo Tension / Compression load cells are perfect for weighing suspended loads or for measuring tensile or compressive forces, breaking loads or weight peaks. They represent the easiest solution to weigh a hopper, a big bag or any other load that has an irregular shape.



COMPRESSION



Dini Argeo Compression load cells are the best solution to weigh medium and large capacity silos, hoppers and tanks. The particular compact shape that characterises them is designed to weigh without mechanical bending, making them very robust and resistant even to extreme stress. Dini Argeo mounting kits for Compression load cells make them particularly easy to install under the structure to be weighed.



COLUMN

Dini Argeo Column load cells are ideal for the construction of weighbridges and large capacity silos weighing. Their shape allows the load to oscillate within the set limits and always return to its original position for optimum weighing. This feature is indispensable in the manufacture of state-of-the-art weighbridges. Using Dini Argeo assembly kits, these load cells can accurately weigh large capacity silos and hoppers.

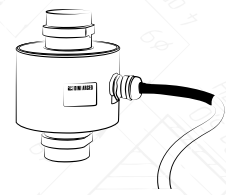

LOAD PINS

The advantage of the weighing pin is that it can be installed in place of an existing mechanical pin around which the movement of a part of the machinery takes place. The weighing pin is made to measure, with mechanical resistance characteristics compatible with those of the existing pin. It is used in moving applications such as mechanical lifting booms, cranes, overhead cranes, AGVs, on-board weighing and agricultural wagons.

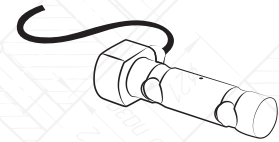

MOUNTING KITS

Dini Argeo mounting kits are designed to simplify the application of load cells to the structures to be weighed, ensuring the best weighing performance. Each accessory offers precise features that make it ideal for specific applications, from belt and roller conveyor scales to the weighing of large capacity silos and hoppers.

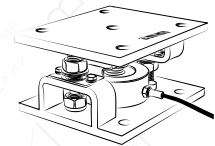

JUNCTION BOXES

Dini Argeo offers a complete range of junction boxes and accessories to connect load cells to weighing electronics.

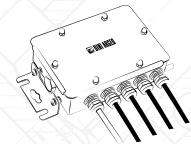

HIGH SPEED PROCESS & AUTOMATION WEIGHT TRANSMITTERS

These weight transmitters are designed for use in applications where a very high sampling rate is required in order to weigh with extreme precision in fractions of a second. Ideal for belt weighing, dosing and micro-dosing, in-line filling and process control applications.

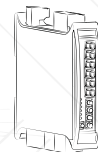

SAFETY & CONTROL WEIGHT TRANSMITTERS

These transmitters are the most convenient and cost-effective solution to create weight control and monitoring applications in industrial processes. They are used to weigh silos, hoppers, roller conveyors and low-speed belts.

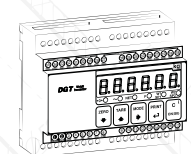

Application key



Weighing belts



Platforms



Hoppers



Roller-conveyors



Tanks and silos



Weighbridges



Suspended loads



Big bags



Weight peaks

SPO | OFF-CENTER

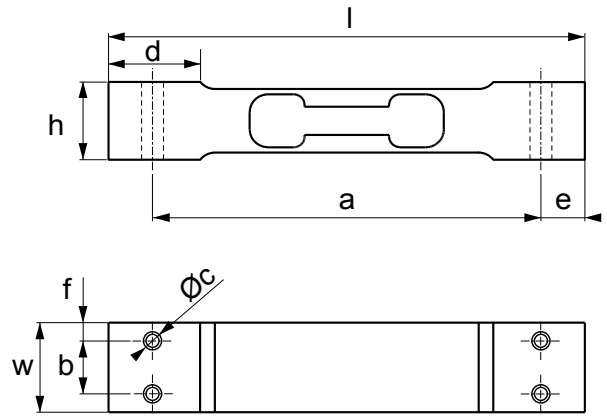

Version codes

Max (kg)	Plate Max (mm)	l (mm)	w (mm)	h (mm)	a (mm)	b (mm)	c Ø (mm)	d (mm)	e (mm)	f (mm)	Code
3	300 x 300	130	25,4	22	106	15	N°4 x M6	25	12	5	SPO3-1
5											SPO5-1
10											SPO10-1
15											SPO15-1
20											SPO20-1
30	SPO30-1										
40	300 x 300	130	30	22	106	15	N°4 x M6	25	12	5	SPO40-1

ATEX Certification

Option	Description	Code
	Optional ATEX version (see www.diniargeo.com for additional details)	CCATEX-1

Technical features

Maximum number of verification intervals	nLC = 3.000
Maximum capacity	40 kg
Y value	Vmin = EMax / 8.000 - 15.000
Nominal rated output	2 mV/V ± 10 %
Temperature effect on full scale output	0,0117 % F.S. / 10 K (-10 °C / +20 °C) 0,0175 % F.S. / 10 K (+20 °C / +40 °C)
Temperature effect on zero	From ± 0,0093 % F.S. / 10 K to ± 0,0175 % F.S. / 10 K
Hysteresis	± 0,0166 % F.S.
Non-linearity	± 0,0166 % F.S.
Creep at nominal load over 30 minutes	-
Input resistance	300...500 Ω
Output resistance	300...500 Ω
Nominal range of excitation voltage	5 - 15 Vdc
Combined error	-
Insulation resistance	> 2.000 MΩ
Zero balance	0 ± 0,12 mV/V (at 100 V)
Compensated temperature range	-10 °C / +40 °C
Operating temperature range	-10 °C / +50 °C
Safe overload	150 % F.S.
Breaking load	300 % F.S.
Nominal displacement	< 0,5 mm
Repeatability	-
Shielded cable	Ø 3,2 mm = 0,4 m

SPD | OFF-CENTER

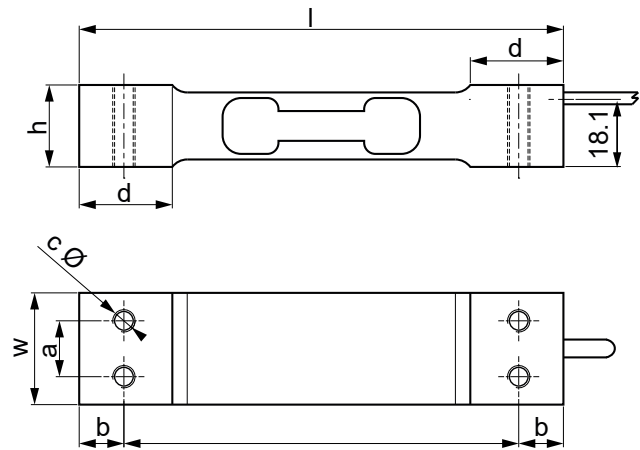

Version codes

Max (kg)	Plate Max (mm)	l (mm)	w (mm)	h (mm)	a (mm)	b (mm)	c Ø (mm)	d (mm)	Code
3	300 x 300	130	24	22	15	12	N°4 x M6	25	SPD3
5									SPD5
10									SPD10
15									SPD15
20	350 x 350	130	30	22	15	12	N°4 x M6	25	SPD20
35									SPD35
75									SPD75
Up to 200	-	-	-	-	-	-	-	-	-

Technical features

Maximum number of verification intervals	-
Maximum capacity	75 kg
Y value	$V_{min} = E_{max} / 10.000$
Nominal rated output	2 mV/V \pm 10%
Temperature effect on full scale output	0,0114 % F.S. / °C
Temperature effect on zero	0,0114 % F.S. / °C
Hysteresis	\pm 0,0166 % F.S.
Non-linearity	\pm 0,0166 % F.S.
Creep at nominal load over 30 minutes	\pm 0,0116 F.S. / °C
Input resistance	406 \pm 15 Ω
Output resistance	350 \pm 3 Ω
Nominal range of excitation voltage	5 - 15 Vdc
Combined error	-
Insulation resistance	> 2.000 M Ω
Zero balance	0 \pm 0,1 mV/V
Compensated temperature range	-10 °C / +40 °C
Operating temperature range	-10 °C / +70 °C
Safe overload	150 % F.S.
Breaking load	300 % F.S.
Nominal displacement	-
Repeatability	-
Shielded cable	 \varnothing 3,8 mm l = 3 m

SPG | OFF-CENTER

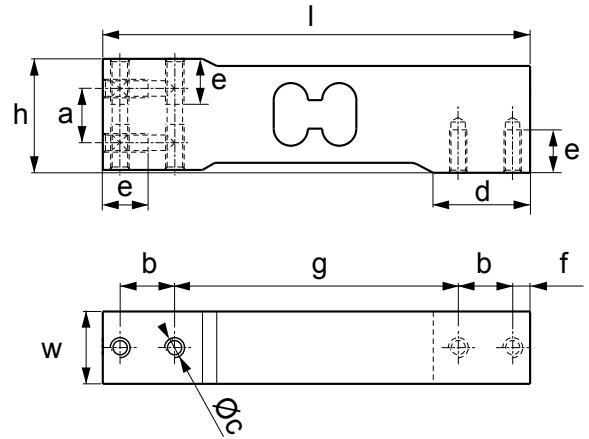

Version codes

Max (kg)	Plate Max (mm)	l (mm)	w (mm)	h (mm)	a (mm)	b (mm)	c Ø (mm)	d (mm)	e (mm)	f (mm)	g (mm)	Code
10	300 x 300	150	25,4	40	19,1	19,1	N°8 x M6	34	16	6,1	99,6	SPG10-1
15												SPG15-1
20	450 x 450	150	25,4	40	19,1	19,1	N°8 x M6	34	16	6,1	99,6	SPG20-1
30												SPG30-1
50												SPG50-1
100	600 x 600	150	25,4	40	19,1	19,1	N°8 x M6	34	16	6,1	99,6	SPG100-1
200												SPG200-1

ATEX Certification

Optimizations	Description	Code
	Optional ATEX version (see www.diniargeo.com for additional details)	CCATEX-1

Technical features

Maximum number of verification intervals	nLC = 3.000
Maximum capacity	200 kg
Y value	Vmin = EMax / 10.000 - 15.000
Nominal rated output	2 mV/V ± 10%
Temperature effect on full scale output	0,011 % F.S. / 10 K (-10 °C / +20 °C) 0,017 % F.S. / 10 K (+20 °C / +40 °C)
Temperature effect on zero	From ± 0,0093 % F.S. / 10 K to ± 0,0140 % F.S. / 10 K
Hysteresis	± 0,0166 % F.S.
Non-linearity	± 0,0166 % F.S.
Creep at nominal load over 30 minutes	-
Input resistance	300...500 Ω
Output resistance	300...500 Ω
Nominal range of excitation voltage	5 - 15 Vdc
Combined error	-
Insulation resistance	> 2.000 MΩ
Zero balance	0 ± 0,12 mV/V (at 100 V)
Compensated temperature range	-10 °C / +40 °C
Operating temperature range	-10 °C / +50 °C
Safe overload	150 % F.S.
Breaking load	300 % F.S.
Nominal displacement	< 0,5 mm
Repeatability	-
Shielded cable	Ø 4,7 mm l = 3 m

SPG C6 | OFF-CENTER

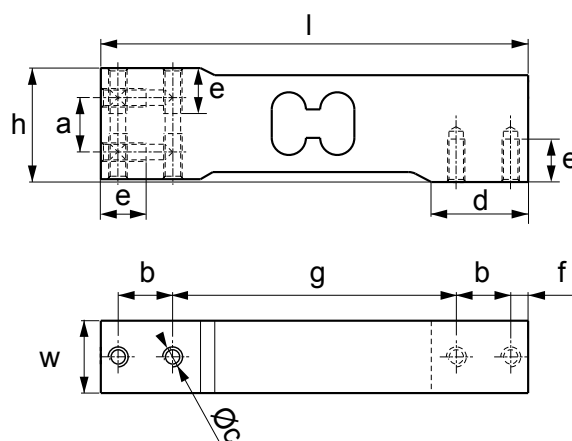

Version codes

Max (kg)	Plate Max (mm)	l (mm)	w (mm)	h (mm)	a (mm)	b (mm)	c Ø (mm)	d (mm)	e (mm)	f (mm)	g (mm)	Code	
7	300 x 300	150	25,4	40	19,1	19,1	N°8 x M6	34	16	6,1	99,6	SPG7C6-1	
10												SPG10C6-1	
18	450 x 450	150	25,4	40	19,1	19,1	N°8 x M6	34	16	6,1	99,6	SPG18C6-1	
36												SPG36C6-1	

ATEX Certification

Option	Description	Code	
	Optional ATEX version (see www.diniargeo.com for additional details)	CCATEX-1	

Technical features

Maximum number of verification intervals	nLC = 6.000
Maximum capacity	36 kg
Y value	Vmin = EMax / 14.000 - 25.000
Nominal rated output	2 mV/V ± 10 %
Temperature effect on full scale output	0,0058 % F.S. / 10 K (-10 °C / +20 °C) 0,087 % F.S. / 10 K (+20 °C / +40 °C)
Temperature effect on zero	From ± 0,0056 % F.S. / 10 K to ± 0,01 % F.S. / 10 K
Hysteresis	± 0,0083 % F.S.
Non-linearity	± 0,0083 % F.S.
Creep at nominal load over 30 minutes	-
Input resistance	300...500 Ω
Output resistance	300...500 Ω
Nominal range of excitation voltage	5 - 15 Vdc
Combined error	-
Insulation resistance	> 2.000 MΩ
Zero balance	0 ± 0,1 mV/V (at 100 V)
Compensated temperature range	-10 °C / +40 °C
Operating temperature range	-10 °C / +50 °C
Safe overload	150 % F.S.
Breaking load	300 % F.S.
Nominal displacement	< 0,5 mm
Repeatability	-
Shielded cable	Ø 4,7 mm l = 3 m

SPM | OFF-CENTER

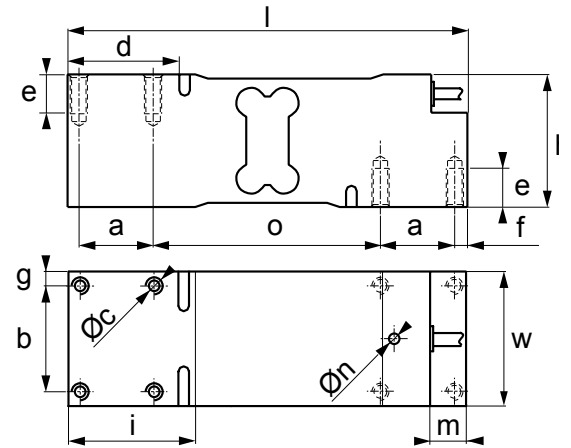
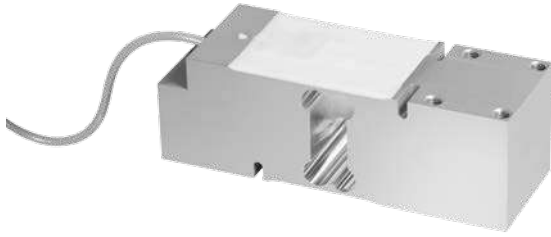

Version codes

Max (kg)	Plate Max (mm)	l (mm)	w (mm)	h (mm)	a (mm)	b (mm)	c Ø (mm)	d (mm)	e (mm)	f (mm)	g (mm)	i (mm)	m (mm)	n (mm)	o (mm)	Code	
100	600 x 600	188	63,5	62,3	35	50	N°8 x M8	52	16	5,5	6,75	60	17	5	107	SPM100	
200																SPM200	
500																SPM500	

ATEX Certification

Option	Description	Code	
	Optional ATEX version (see www.diniargeo.com for additional details)	CCATEX-1	

Technical features

Maximum number of verification intervals	nLC = 3.000
Maximum capacity	500 kg
Y value	Vmin = EMax / 10.000 - 15.000
Nominal rated output	2 mV/V ± 10%
Temperature effect on full scale output	± 0,0117 % F.S. / 10 K (-10 °C / +20 °C) ± 0,0175 % F.S. / 10 K (+20 °C / +40 °C)
Temperature effect on zero	From ± 0,0093 % F.S. / 10 K to ± 0,0140 % F.S. / 10 K
Hysteresis	± 0,0166 % F.S.
Non-linearity	± 0,0166 % F.S.
Creep at nominal load over 30 minutes	-
Input resistance	300...500 Ω
Output resistance	300...500 Ω
Nominal range of excitation voltage	5 - 15 Vdc
Combined error	-
Insulation resistance	> 2.000 MΩ
Zero balance	0 ± 0,1 mV/V (at 100 V)
Compensated temperature range	-10 °C / +40 °C
Operating temperature range	-10 °C / +50 °C
Safe overload	150 % F.S.
Breaking load	300 % F.S.
Nominal displacement	< 0,5 mm
Repeatability	-
Shielded cable	

SPBC | OFF-CENTER

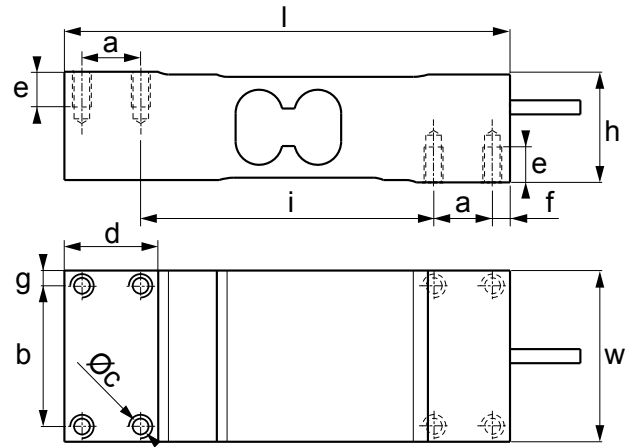

Version codes

Max (kg)	Plate Max (mm)	l (mm)	w (mm)	h (mm)	a (mm)	b (mm)	c Ø (mm)	d (mm)	e (mm)	f (mm)	g (mm)	i (mm)	Code
100	700 x 700	190	73	47	25	60	N°8 x M8	40	15	7,5	6,5	125	SPBC100
200													SPBC200
300													SPBC300
500													SPBC500
630													SPBC630

ATEX Certification

Option	Description	Code
	Optional ATEX version (see www.diniargeo.com for additional details)	CCATEX-1

Technical features

Maximum number of verification intervals	nLC = 3.000
Maximum capacity	630 kg
Y value	Vmin = EMax / 10.000
Nominal rated output	2 mV/V ± 10 %
Temperature effect on full scale output	0,0014 % / °C
Temperature effect on zero	0,0014 % / °C
Hysteresis	-
Non-linearity	-
Creep at nominal load over 30 minutes	0,025 % F.S.
Input resistance	410 ± 20 Ω
Output resistance	350 ± 5 Ω
Nominal range of excitation voltage	5 - 15 Vdc
Combined error	0,017 % F.S.
Insulation resistance	> 1.000 MΩ
Zero balance	± 10 % F.S.
Compensated temperature range	-10 °C / +40 °C
Operating temperature range	-20 °C / +60 °C
Safe overload	150 % F.S.
Breaking load	200 % F.S.
Nominal displacement	-
Repeatability	-
Shielded cable	Ø 5 mm l = 3 m

SPN | OFF-CENTER

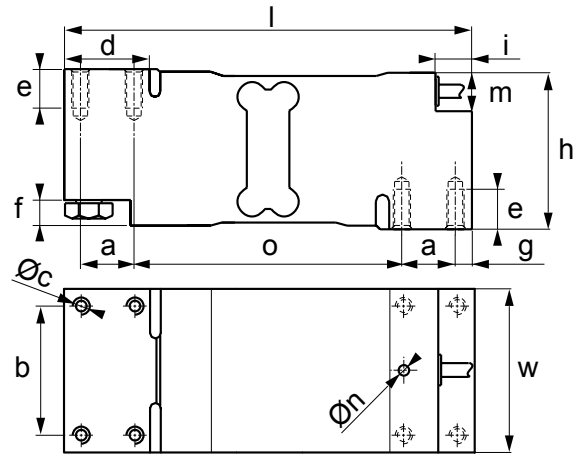

Version codes

Max (kg)	Plate Max (mm)	l (mm)	w (mm)	h (mm)	a (mm)	b (mm)	c Ø (mm)	d (mm)	e (mm)	f (mm)	g (mm)	i (mm)	m (mm)	n Ø (mm)	o (mm)	Code
300	800 x 800	191	76	75	25	60	N°8 x M8	40	16	12	8	21	18	5	125	SPN300
500																SPN500
750																SPN750

ATEX Certification

Option	Description	Code
	Optional ATEX version (see www.diniargeo.com for additional details)	CCATEX-1

Technical features

Maximum number of verification intervals	nLC = 3.000
Maximum capacity	750 kg
Y value	Vmin = EMax / 10.000 - 15.000
Nominal rated output	2 mV/V ± 10 %
Temperature effect on full scale output	0,0117 % F.S. / 10 K (-10 °C / +20 °C) 0,0175 % F.S. / 10 K (+20 °C / +40 °C)
Temperature effect on zero	From ± 0,0093 % F.S. / 10 K to ± 0,0140 % F.S. / 10 K
Hysteresis	± 0,0166 % F.S.
Non-linearity	± 0,0166 % F.S.
Creep at nominal load over 30 minutes	-
Input resistance	300...500 Ω
Output resistance	300...500 Ω
Nominal range of excitation voltage	5 - 15 Vdc
Combined error	-
Insulation resistance	> 2.000 MΩ
Zero balance	0 ± 0,1 mV/V (at 100 V)
Compensated temperature range	-10 °C / +40 °C
Operating temperature range	-10 °C / +50 °C
Safe overload	150 % F.S.
Breaking load	300 % F.S.
Nominal displacement	< 0,5 mm
Repeatability	-
Shielded cable	Ø 5 mm l = 3 m

SPSW | OFF-CENTER

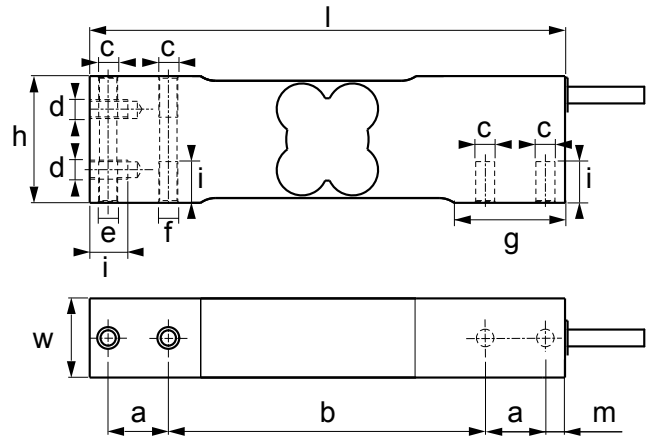

Version codes

Max (kg)	Plate Max (mm)	l (mm)	w (mm)	h (mm)	a (mm)	b (mm)	c Ø (mm)	d Ø (mm)	e Ø (mm)	f Ø (mm)	g (mm)	i (mm)	m (mm)	Code
7,5	500 x 400	150	25	40	19	100	N°4 x M6	N°2 x M6	M6	M6 x 0,5 (1 x)	35	13	6,2	SPSW7.5
15														SPSW15
30														SPSW30
50														SPSW50
100														SPSW100
200	500 x 400	150	25	40	19	100	N°4 x M8	N°2 x M6	5,1	M6 x 0,5 (1 x)	35	13	6,2	SPSW200

ATEX Certification

Option	Description	Code
	Optional ATEX version (see www.diniargeo.com for additional details)	CCATEX-1



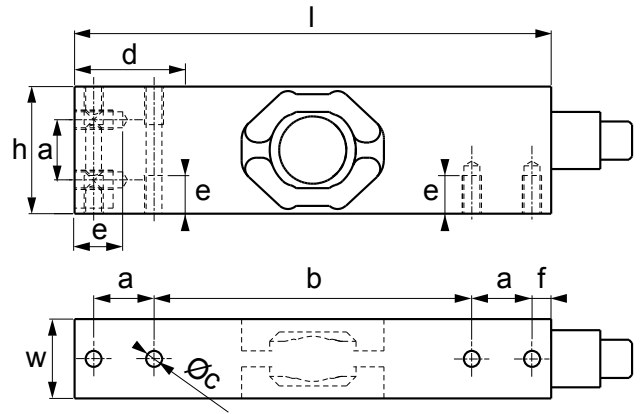
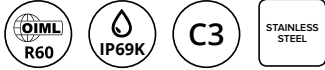

Technical features

Maximum number of verification intervals	nLC = 3.000
Maximum capacity	200 kg
Y value	Vmin = EMax / 10.000 - 15.000
Nominal rated output	2 mV/V ± 10 %
Temperature effect on full scale output	± 0,0117 % F.S. / 10 K (-10 °C / +20 °C) ± 0,0175 % F.S. / 10 K (+20 °C / +40 °C)
Temperature effect on zero	From ± 0,0093 % F.S. / 10 K to ± 0,0140 % F.S. / 10 K
Hysteresis	± 0,0166 % F.S.
Non-linearity	± 0,0166 % F.S.
Creep at nominal load over 30 minutes	-
Input resistance	300...500 Ω
Output resistance	300...500 Ω
Nominal range of excitation voltage	5 - 15 Vdc
Combined error	-
Insulation resistance	> 1.000 MΩ (at 100 V)
Zero balance	0 ± 0,1 mV/V
Compensated temperature range	-10 °C / +40 °C
Operating temperature range	-10 °C / +50 °C
Safe overload	150 % F.S.
Breaking load	300 % F.S.
Nominal displacement	< 0,2 mm
Repeatability	-
Shielded cable	Ø 5 mm l = 3 m

SPSY | OFF-CENTER



Version codes

Max (kg)	Plate Max (mm)	l (mm)	w (mm)	h (mm)	a (mm)	b (mm)	c Ø (mm)	d (mm)	e (mm)	f (mm)	Code
10	500 x 400	150	25	40	19	100	N°8 x M6	35	12	6	SPSY10 
20											SPSY20 
50											SPSY50 
100											SPSY100 

Technical features

Maximum number of verification intervals	nLC = 3.000
Maximum capacity	100 kg
Y value	Vmin = EMax / 10.000
Nominal rated output	2 mV/V ± 10 %
Temperature effect on full scale output	± 0,0117 % F.S. / 10 K (-10 °C / +20 °C) ± 0,0175 % F.S. / 10 K (+20 °C / +40 °C)
Temperature effect on zero	± 0,014 % F.S. / 10 K
Hysteresis	± 0,0166 % F.S.
Non-linearity	± 0,0166 % F.S.
Creep at nominal load over 30 minutes	-
Input resistance	300...500 Ω
Output resistance	300...500 Ω
Nominal range of excitation voltage	5 - 15 Vdc
Combined error	-
Insulation resistance	> 1.000 MΩ (at 100 V)
Zero balance	0 ± 0,1 mV/V
Compensated temperature range	-10 °C / +40 °C
Operating temperature range	-10 °C / +50 °C
Safe overload	150 % F.S.
Breaking load	300 % F.S.
Nominal displacement	< 0,5 mm
Repeatability	-
Shielded cable	 Ø 5 mm l = 3 m

SPSX | OFF-CENTER

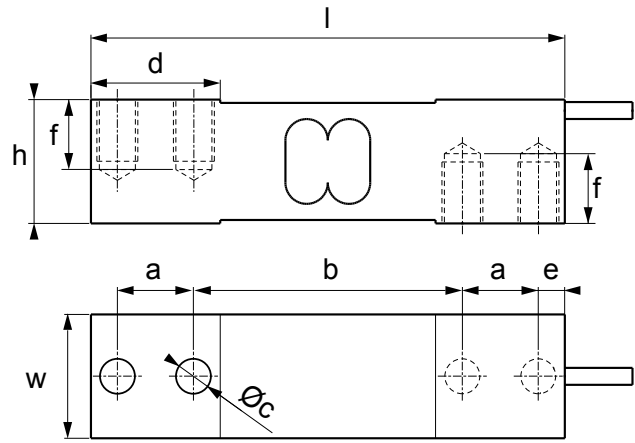

Version codes

Max (kg)	Plate Max (mm)	l (mm)	w (mm)	h (mm)	a (mm)	b (mm)	c Ø (mm)	d (mm)	e (mm)	f (mm)	Code	
100	800 x 800	139,7	30,5	30,2	22,4	79,3	N°4 x M10	38	7,8	15	SPSX100	
300	800 x 800	139,7	30,5	30,2	22,4	79,3	N°4 x M10	38	7,8	15	SPSX300	
500	800 x 800	139,7	36,5	36,5	22,4	79,3	N°4 x M12	38	7,8	19	SPSX500	

ATEX Certification

Option	Description	Code	
	Optional ATEX version (see www.diniargeo.com for additional details)	CCATEX-1	

Technical features

Maximum number of verification intervals	nLC = 3.000
Maximum capacity	500 kg
Y value	Vmin = EMax / 10.000 - 15.000
Nominal rated output	2 mV/V ± 10 %
Temperature effect on full scale output	± 0,0117 % F.S. / 10 K (-10 °C / +20 °C) ± 0,0170 % F.S. / 10 K (+20 °C / +40 °C)
Temperature effect on zero	From ± 0,0093 % F.S. / 10 K to ± 0,0140 % F.S. / 10 K
Hysteresis	± 0,0166 % F.S.
Non-linearity	± 0,0166 % F.S.
Creep at nominal load over 30 minutes	-
Input resistance	390 ± 15 Ω
Output resistance	359 ± 10 Ω
Nominal range of excitation voltage	5 - 15 Vdc
Combined error	-
Insulation resistance	> 2.000 MΩ (at 100 V)
Zero balance	0 ± 0,1 mV/V
Compensated temperature range	-10 °C / +40 °C
Operating temperature range	-10 °C / +50 °C
Safe overload	150 % F.S.
Breaking load	300 % F.S.
Nominal displacement	< 0,5 mm
Repeatability	-
Shielded cable	Ø 5 mm l = 3 m

SPSZ | OFF-CENTER

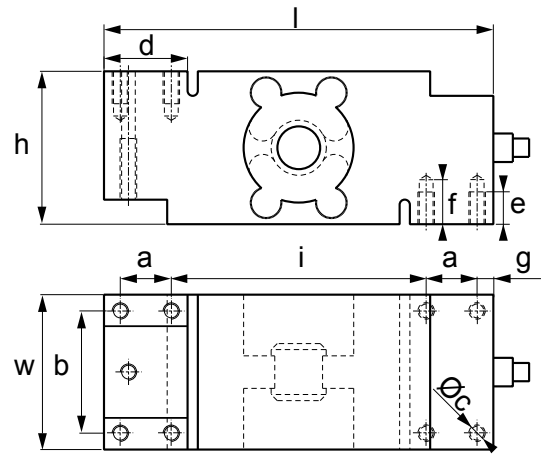

Version codes

Max (kg)	Plate Max (mm)	l (mm)	w (mm)	h (mm)	a (mm)	b (mm)	c Ø (mm)	d (mm)	e (mm)	f (mm)	g (mm)	i (mm)	Code	
500	800 x 800	191	76	75	25	60	N°9 x M12	41	16	22	8	125	SPSZ500	
1.000													SPSZ1000	

Technical features

Maximum number of verification intervals	nLC = 3.000
Maximum capacity	1.000 kg
Y value	$V_{min} = E_{Max} / 10.000$
Nominal rated output	2 mV/V \pm 10 %
Temperature effect on full scale output	$\pm 0,0117$ % F.S. / 10 K (-10 °C / +20 °C) $\pm 0,0170$ % F.S. / 10 K (+20 °C / +40 °C)
Temperature effect on zero	From $\pm 0,0112$ % F.S. / 10 K to $\pm 0,0186$ % F.S. / 10 K
Hysteresis	$\pm 0,0166$ % F.S.
Non-linearity	$\pm 0,0166$ % F.S.
Creep at nominal load over 30 minutes	$\pm 0,01$ % F.S.
Input resistance	380 \pm 15 Ω
Output resistance	300...500 Ω
Nominal range of excitation voltage	5 - 15 Vdc
Combined error	-
Insulation resistance	> 2.000 M Ω (at 100 V)
Zero balance	-
Compensated temperature range	-10 °C / +40 °C
Operating temperature range	-10 °C / +50 °C
Safe overload	150 % F.S.
Breaking load	300 % F.S.
Nominal displacement	< 0,3 mm
Repeatability	-
Shielded cable	Ø 5 mm l = 3 m

FXC | BENDING BEAM

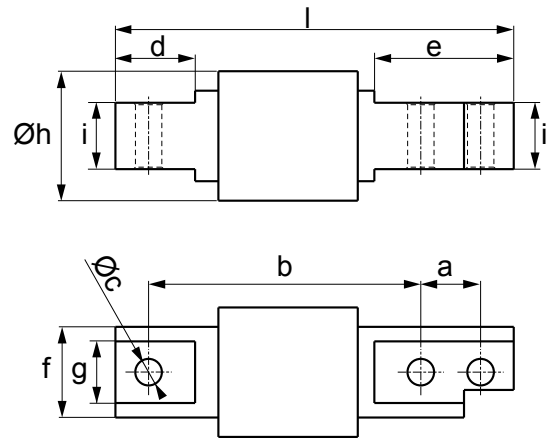

Version codes

Max (kg)	l (mm)	h Ø (mm)	a (mm)	b (mm)	c Ø (mm)	d (mm)	e (mm)	f (mm)	g (mm)	i (mm)	Code
10	120	39	18	82	N°3 x 8	24	42	27,3	18,5	20	FXC10-1
20											FXC20-1
50											FXC50-1
100											FXC100-1
200											FXC200-1
300											FXC300-1
500											FXC500-1

ATEX Certification



Option	Description	Code
	Optional ATEX version (see www.diniargeo.com for additional details)	CCATEX-1

Technical features

Maximum number of verification intervals	nLC= 3.000
Maximum capacity	500 kg
Y value	Vmin = EMax / 10.000
Nominal rated output	2 mV/V ± 1 %
Temperature effect on full scale output	± 0,0014 % / °C
Temperature effect on zero	± 0,0014 % / °C
Hysteresis	-
Non-linearity	-
Creep at nominal load over 30 minutes	± 0,025 % F.S.
Input resistance	385 ± 20 Ω
Output resistance	350 ± 5 Ω
Nominal range of excitation voltage	5 - 15 Vdc
Combined error	0,017 % F.S.
Insulation resistance	> 5.000 MΩ
Zero balance	± 2,5 % F.S.
Compensated temperature range	-10 °C / +40 °C
Operating temperature range	-20 °C / +60 °C
Safe overload	150 % F.S.
Breaking load	200 % F.S.
Nominal displacement	< 0,4 mm
Repeatability	0,015 % F.S.
Shielded cable	Ø 4 mm l = 3 m

Main options and accessories (for a complete list visit www.diniargeo.com)

Mounting kits	Material	Max capacity (kg)	Max lift-off force (kN)	Max side force (kN)	Code	
	Stainless steel	Up to 500 kg	-	-	KFX (load cell not included)	
	Stainless steel	Up to 500 kg	-	-	KFXDN-1 (load cell not included)	

Joints	Material	Description	Threading	Code	
	Stainless steel / Rubber	Elastic joint for load cells up to 500 kg	M8 x 32 mm	AVM8	
	Stainless steel	Ball joint perfect to improve weighing performance	∅ 8,3 x 9 mm	SBJ8	

Base plates	Material	Description	Hole size	Code	
	Stainless steel	Thickness for load cells up to 500 kg. Size (l x w x h): 42 x 30 x 10 mm.	∅ 9 mm (for M8 screw)	BPFX10	

FXC C6 | BENDING BEAM

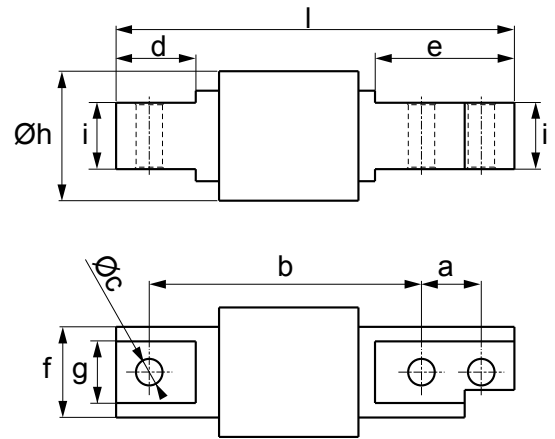

Version codes

Max (kg)	l (mm)	h Ø (mm)	a (mm)	b (mm)	c Ø (mm)	d (mm)	e (mm)	f (mm)	g (mm)	i (mm)	Code
20	120	39	18	82	N°3 x 8	24	42	27,3	18,5	20	FXC20C6-1
50											FXC50C6-1
100											FXC100C6-1
200											FXC200C6-1

ATEX Certification

Option	Description	Code
	Optional ATEX version (see www.diniargeo.com for additional details)	CCATEX-1

Technical features

Maximum number of verification intervals	nLC = 6.000
Maximum capacity	200 kg
Y value	Vmin = EMax / 10.000
Nominal rated output	2 mV/V ± 1 %
Temperature effect on full scale output	± 0,0007 % / °C
Temperature effect on zero	± 0,0014 % / °C
Hysteresis	-
Non-linearity	-
Creep at nominal load over 30 minutes	± 0,012 % F.S.
Input resistance	385 ± 20 Ω
Output resistance	350 ± 5 Ω
Nominal range of excitation voltage	5 - 15 Vdc
Combined error	0,008 % F.S.
Insulation resistance	> 5.000 MΩ
Zero balance	± 2,5 % F.S.
Compensated temperature range	-10 °C / +40 °C
Operating temperature range	-20 °C / +60 °C
Safe overload	150 % F.S.
Breaking load	200 % F.S.
Nominal displacement	-
Repeatability	-
Shielded cable	Ø 4 mm l = 3 m

Main options and accessories (for a complete list visit www.diniargeo.com)

Mounting kits	Material	Max capacity (kg)	Max lift-off force (kN)	Max side force (kN)	Code	
	Stainless steel	Up to 500 kg	-	-	KFX (load cell not included)	
	Stainless steel	Up to 500 kg	-	-	KFXDN-1 (load cell not included)	

Joints	Material	Description	Threading	Code	
	Stainless steel / Rubber	Elastic joint for load cells up to 500 kg	M8 x 32 mm	AVM8	
	Stainless steel	Ball joint perfect to improve weighing performance	∅ 8,3 x 9 mm	SBJ8	

Base plates	Material	Description	Hole size	Code	
	Stainless steel	Thickness for load cells up to 500 kg. Size (l x w x h): 42 x 30 x 10 mm.	∅ 9 mm (for M8 screw)	BPFX10	

FXD | BENDING BEAM

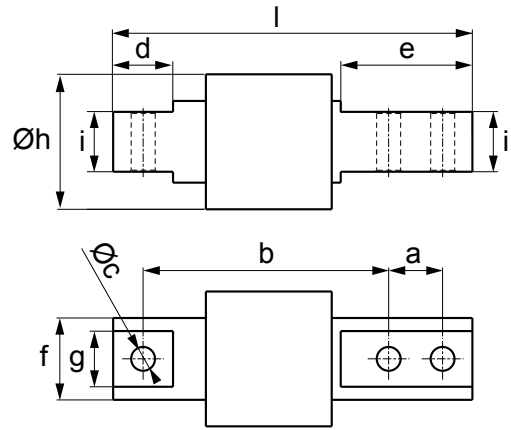

Version codes

Max (kg)	l (mm)	h Ø (mm)	a (mm)	b (mm)	c Ø (mm)	d (mm)	e (mm)	f (mm)	g (mm)	i (mm)	Code
10	120	45	18	82	N°3 x 8	20	44	27,3	18,6	20	FXD10
20											FXD20
50											FXD50
100											FXD100
200											FXD200
300											FXD300
500											FXD500

ATEX Certification



Option	Description	Code
	Optional ATEX version (see www.diniargeo.com for additional details)	CCATEX-1

Technical features

Maximum number of verification intervals	nLC= 3.000
Maximum capacity	500 kg
Y value	Vmin = EMax / 10.000
Nominal rated output	2 mV/V ± 0,1 %
Temperature effect on full scale output	± 0,02 % F.S. / 10 °C
Temperature effect on zero	± 0,02 % F.S. / 10 °C
Hysteresis	± 0,02 % F.S.
Non-linearity	± 0,02 % F.S.
Creep at nominal load over 30 minutes	± 0,012 % F.S.
Input resistance	385 ± 10 Ω
Output resistance	350 ± 3 Ω
Nominal range of excitation voltage	5 - 15 Vdc
Combined error	0,012 % F.S.
Insulation resistance	> 5.000 MΩ
Zero balance	1 % F.S.
Compensated temperature range	-10 °C / +50 °C
Operating temperature range	-20 °C / +60 °C
Safe overload	120 % F.S.
Breaking load	150 % F.S.
Nominal displacement	< 0,4 mm
Repeatability	± 0,01 % F.S.
Shielded cable	Ø 5 mm l = 3 m

Main options and accessories (for a complete list visit www.diniargeo.com)

Mounting kits	Material	Max capacity (kg)	Max lift-off force (kN)	Max side force (kN)	Code	
	Stainless steel	Up to 500 kg	-	-	KFX (load cell not included)	
	Stainless steel	Up to 500 kg	-	-	KFXDN-1 (load cell not included)	

Joints	Material	Description	Threading	Code	
	Stainless steel / Rubber	Elastic joint for load cells up to 500 kg	M8 x 32 mm	AVM8	
	Stainless steel	Ball joint perfect to improve weighing performance	∅ 8,3 x 9 mm	SBJ8	

Base plates	Material	Description	Hole size	Code	
	Stainless steel	Thickness for load cells up to 500 kg. Size (l x w x h): 42 x 30 x 10 mm.	∅ 9 mm (for M8 screw)	BPFX10	

KFX | MOUNTING KIT

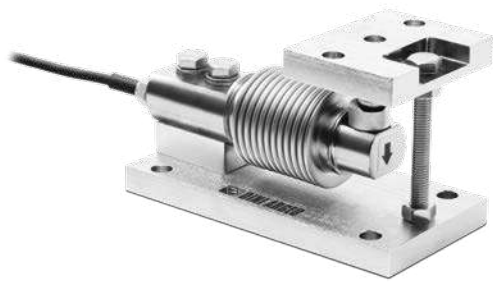

Mounting kits for FXC / FXD series bending beam load cells up to 500 kg with single anti-tipping system and side force compensation. Suitable for weighing belts, small and medium hoppers, tanks and mixers. Fitted with ball joint for high-precision weighing.



Version codes

Mounting kits	Material	Weight (kg)	Max capacity (kg)	Max lift-off force (kN)	Max side force (kN)	Code	
	Stainless steel	1,5	Up to 500 kg (load cell capacity)	-	-	KFX	



ATEX certification

Option	Description	Code	
	ATEX declaration for the PLATFORM / LOAD CELL ASSEMBLY KIT (for load cell ATEX declaration see CCATEX code). Option to be offered only if the platform is ordered without the indicator, otherwise refer to the available certifications for the chosen weight indicator.	DCATEXMECH	

Technical features

Construction in electropolished stainless steel AISI 304
Anti-tipping system
Locking/bypass system for easy transport and maintenance
Overload protection nuts
Grounding cable for protection against electrostatic discharges
ATEX version available for zones 1&21, 2&22

Main options and accessories (for a complete list visit www.diniargeo.com)

Option	Description	Code	
	Galvanised stay rod with ball-and-socket joints. Max 100 kN. For proper installation, 2xLNKST are needed.	LNK2635	
	Single plate for stay rod. Fitted with fixing screw. For proper installation, LNK2635 and a second LNKST are needed.	LNKST	

This kit is designed to allow the correct functioning of the cells and the requested weighing accuracy, within the limits described into the technical manual.

Technical drawing (mm)

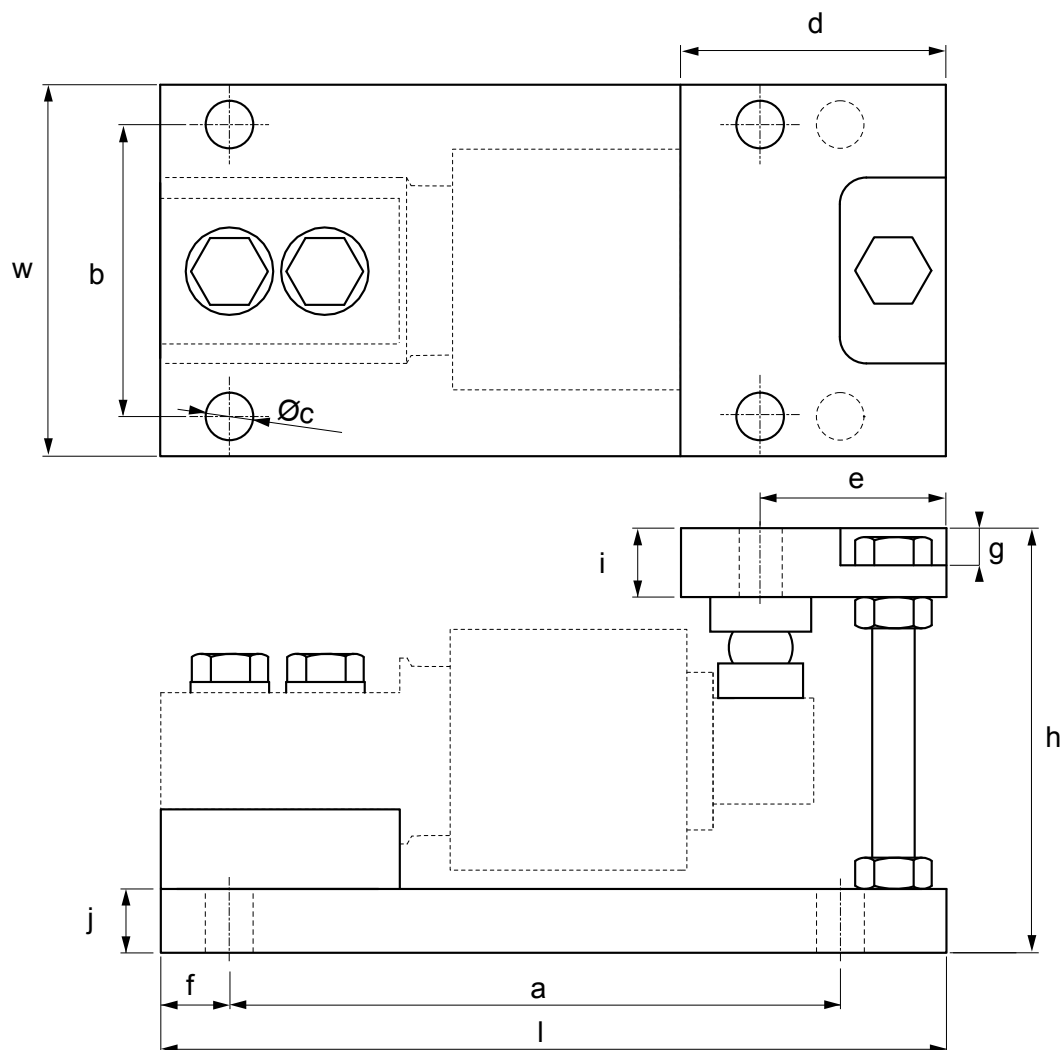

Max (kg)	l (mm)	w (mm)	h (mm)	a (mm)	b (mm)	c \varnothing (mm)	d (mm)	e (mm)	f (mm)	g (mm)	i (mm)	j (mm)	Code
500	148	70	80	115	55	N°6 x 9	50	35	13	7	13	12	KFX

KFXDN | MOUNTING KIT



Mounting kits for FXC / FXD series bending beam load cells up to 500 kg. Suitable for weighing belts, small and medium hoppers, tanks and mixers.



Version codes

Mounting kits	Material	Weight (kg)	Max capacity (kg)	Max lift-off force (kN)	Max side force (kN)	Code	
	Stainless steel	1,4	Up to 300 kg (load cell capacity)	-	-	KFXDN-1 (Load cell not included)	



ATEX certification

Option	Description	Code	
	ATEX declaration for the PLATFORM / LOAD CELL ASSEMBLY KIT (for load cell ATEX declaration see CCATEX code). Option to be offered only if the platform is ordered without the indicator, otherwise refer to the available certifications for the chosen weight indicator.	DCATEXMECH	

Technical features

Construction in stainless steel AISI 304
Locking / bypass system for easy transport and maintenance
Upper plate with elastic joint for vibration absorption and expansion compensation
ATEX version available for zones 1&21, 2&22

Main options and accessories (for a complete list visit www.diniargeo.com)

Option	Description	Code	
	Galvanised stay rod with ball-and-socket joints. Max 100 kN. For proper installation, 2xLNKST are needed.	LNK2635	
	Single plate for stay rod. Fitted with fixing screw. For proper installation, LNK2635 and a second LNKST are needed.	LNKST	
	Grounded cable for weighing kit. 16 mm ² cable, 13 mm eyelets.	GNDC	

This kit is designed to allow the correct functioning of the cells and the requested weighing accuracy, within the limits described into the technical manual.

Technical drawing (mm)

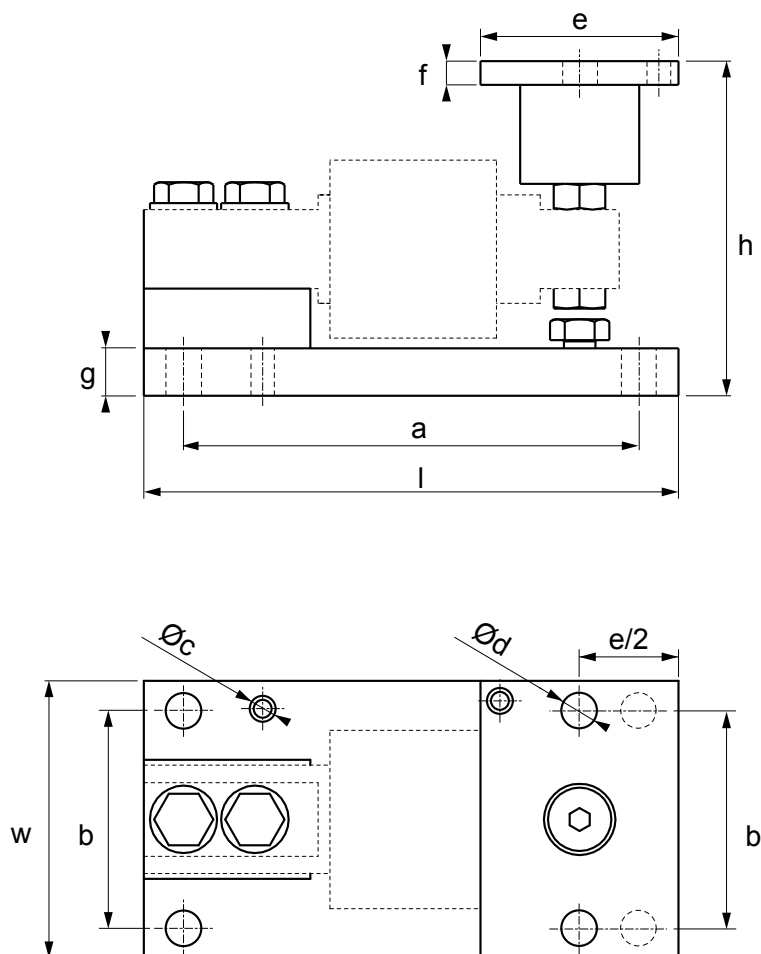

Max (kg)	l (mm)	w (mm)	h (mm)	a (mm)	b (mm)	c \varnothing (mm)	d \varnothing (mm)	e (mm)	f (mm)	g (mm)	Code
500	135	70	84,5	115	55	N°2 x 5	N°6 x 9	50	6	12	KFXDN-1

SBT | SHEAR BEAM

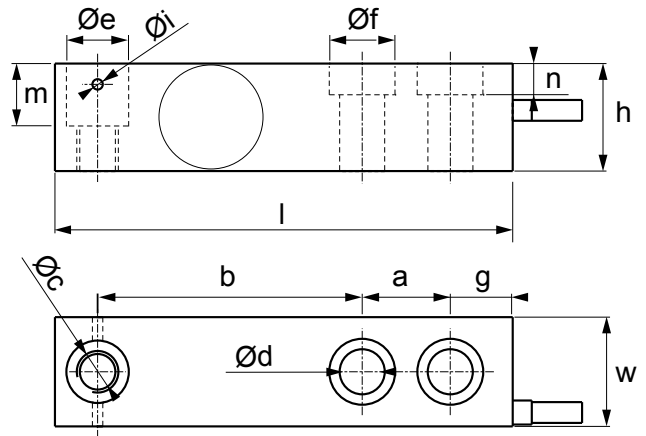
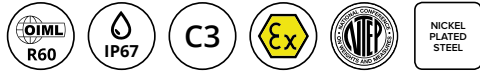

Version codes

Max (kg)	l (mm)	w (mm)	h (mm)	a (mm)	b (mm)	c Ø (mm)	d Ø (mm)	e Ø (mm)	f Ø (mm)	g (mm)	i Ø (mm)	m (mm)	n (mm)	Code
500	132	31,5	31	25,4	76,3	N°1 x M12	N°2 x 13	18	19	18	3	18	9	SBT500
1.000														SBT1000
2.000														SBT2000

ATEX certification



Option	Description	Code
	Optional ATEX version (see www.diniargeo.com for additional details).	CCATEX3GD

Technical features

Maximum number of verification intervals	nLC = 3.000
Maximum capacity	2.000 kg
Y value	Vmin = EMax / 10.000
Nominal rated output	2 mV/V ± 0,5 %
Temperature effect on full scale output	0,02 % F.S. / 10 °C
Temperature effect on zero	0,02 % F.S. / 10 °C
Hysteresis	± 0,02 % F.S.
Non-linearity	± 0,02 % F.S.
Creep at nominal load over 30 minutes	0,02 % F.S.
Input resistance	380 ± 20 Ω
Output resistance	350 ± 5 Ω
Nominal range of excitation voltage	5 - 15 Vdc
Combined error	0,017 % F.S.
Insulation resistance	> 5.000 MΩ
Zero balance	± 1 % F.S.
Compensated temperature range	-10 °C / +50 °C
Operating temperature range	-20 °C / +60 °C
Safe overload	120 % F.S.
Breaking load	300 % F.S.
Nominal displacement	-
Repeatability	± 0.01 % F.S.
Shielded cable	Ø 5 mm l = 3,5 m



Main options and accessories (for a complete list visit www.diniargeo.com)

Mounting kits	Material	Max capacity (kg)	Max lift-off force (kN)	Max side force (kN)	Code	
	Nickel-plated steel	2.500 kg	10	-	KSBC2 (load cell not included)	
	Galvanised steel	2.500 kg	-	-	KSBN2 (load cell not included)	
	Stainless steel	2.500 kg	10	-	KSBX2 (load cell not included)	
	Stainless steel	2.000 kg	-	-	KSB2H	

Option	Description	Code	
	Galvanised stay rod with ball-and-socket joints. Max 100 kN. For proper installation, 2xLNKST are needed.	LNK2635	
	Single plate for stay rod. Fitted with fixing screw. For proper installation, LNK2635 and a second LNKST are needed.	LNKST	
	Grounded cable for weighing kit. 16 mm ² cable, 13 mm eyelets.	GNDC	

This kit is designed to allow the correct functioning of the cells and the requested weighing accuracy, within the limits described into the technical manual.

Foot	Material	Load cell compatibility	Threading	Code	
	Stainless steel	For load cells up to 2.500 kg	M12 x 43 mm	SBFI-1	
	Stainless steel	For load cells up to 2.500 kg	M12 x 45 mm	KSB2FI-1	
	Nickel-plated steel	For load cells up to 2.500 kg	M12 x 45 mm	SBFA	
Bushes	Material	Foot compatibility	Threading	Code	
	Stainless steel	M12 bush	M12 x 25 mm	BLKM12I	

Joints	Material	Description	Threading	Code	
	Stainless steel / Rubber	Elastic joint for load cells up to 2.500 kg	M12 x 32 mm	AVM12	
	Stainless steel	Ball joint perfect to improve weighing performance	M12 x 32 mm	SBJ12	

Base plates	Material	Description	Hole size	Code	
	Stainless steel	Thickness for load cells up to 2.500 kg. Size (l x w x h): 55 x 30 x 5 mm.	N° 2 x Ø 13 mm	BPSB5	
	Stainless steel	Thickness for load cells up to 2.500 kg. Size (l x w x h): 55 x 30 x 3 mm.	N° 2 x Ø 13 mm	BPSB3	

SBX | SHEAR BEAM

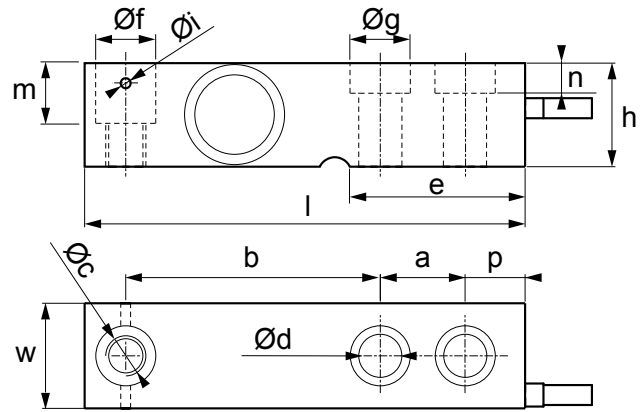

Version codes

Max (kg)	l (mm)	w (mm)	h (mm)	a (mm)	b (mm)	c Ø (mm)	d Ø (mm)	e (mm)	f Ø (mm)	g Ø (mm)	i Ø (mm)	m (mm)	n (mm)	p (mm)	Code
500	132	31,5	31	25,4	76,3	N°1 x M12	N°2 x 13	52,5	18	18	3	18	9	18	SBX500-1KL
1.000															SBX1000-1KL
2.000															SBX2000-1KL
2.500															SBX2500-1KL
3.000	171,5	38	38	38,1	95,3	N°1 x M20	N°2 x 20,5	70	30,2	28	-	19	10	19,1	SBX3000-1KL
4.500															SBX4500-1KL
10.000	222,5	50,8	50,8	50,8	123,8	N°1 x M24	N°2 x 27	95	27	-	-	26	-	25,4	SBX10000-1KL

Technical features

Maximum number of verification intervals	nLC = 3.000
Maximum capacity	10.000 kg
Y value	Vmin = EMax / 10.000
Nominal rated output	2 mV/V +/- 0,5 %
Temperature effect on full scale output	0,002 % / °C
Temperature effect on zero	0,002 % / °C
Hysteresis	0,02 % F.S.
Non-linearity	0,02 % F.S.
Creep at nominal load over 30 minutes	0,02 % F.S.
Input resistance	1.100 ± 20 Ω
Output resistance	1.000 ± 20 Ω
Nominal range of excitation voltage	5 - 15 Vdc
Combined error	0,017 % F.S.
Insulation resistance	> 5.000 MΩ
Zero balance	-
Compensated temperature range	-10 °C / +50 °C
Operating temperature range	-20 °C / +60 °C
Safe overload	120 % F.S.
Breaking load	300 % F.S.
Nominal displacement	-
Repeatability	-
Shielded cable	Ø 5 mm l = 5 m



Certifications



Option	Description	Code
	Optional ATEX version (see www.diniargeo.com for additional details)	CCATEX-1
	IP69K version for one load cell	IP69KLC



Main options and accessories (for a complete list visit www.diniargeo.com)

Mounting Kits	Material	Max capacity (kg)	Max lift-off force (kN)	Max side force (kN)	Code	
	Nickel-plated steel	2.500 kg	10	-	KSBC2 (load cell not included)	
	Galvanised steel	2.500 kg	-	-	KSBN2 (load cell not included)	
	Stainless steel	2.500 kg	10	-	KSBX2 (load cell not included)	
	Stainless steel	2.000 kg	-	-	KSB2H	
	Stainless steel	3.000 / 5.000 kg	-	-	KSB5H	

Feet	Material	Load cell compatibility	Threading	Code	
	Stainless steel	For load cells up to 2.500 kg	M12 x 43 mm	SBFI-1	
	Stainless steel	For load cells from 3.000 to 5.000 kg	M20 x 46,5 mm	SBFI3K-1	
	Stainless steel	For load cells up to 2.500 kg	M12 x 45 mm	KSB2FI-1	
	Stainless steel	For load cells from 3.000 to 5.000 kg	M20 x 45 mm	KSB5FI-1	
	Nickel-plated steel	For load cells up to 2.500 kg	M12 x 45 mm	SBFA	

Bushes	Material	Foot compatibility	Threading	Code	
	Stainless steel	M12 bush	M12 x 25 mm	BLKM12I	
	Stainless steel	M20 bush	M12 x 26 mm	BLKM20I	

Joints	Material	Description	Threading	Code	
	Stainless steel / Rubber	Elastic joint for load cells up to 2.500 kg	M12 x 32 mm	AVM12	
	Stainless steel	Ball joint perfect to improve weighing performance	M12 x 32 mm	SBJ12	

Base plates	Material	Description	Hole size	Code	
	Stainless steel	Thickness for load cells up to 2.500 kg. Size (l x w x h): 55 x 30 x 5 mm.	N° 2 x ø 13 mm	BPSB5	
	Stainless steel	Thickness for load cells up to 2.500 kg. Size (l x w x h): 55 x 30 x 3 mm.	N° 2 x ø 13 mm	BPSB3	
	Stainless steel	Thickness for load cells from 3.000 to 4.500 kg. Size (l x w x h): 70 x 40 x 5 mm.	N° 2 x ø 20 mm	BPSBX5	

SBK C6 | SHEAR BEAM

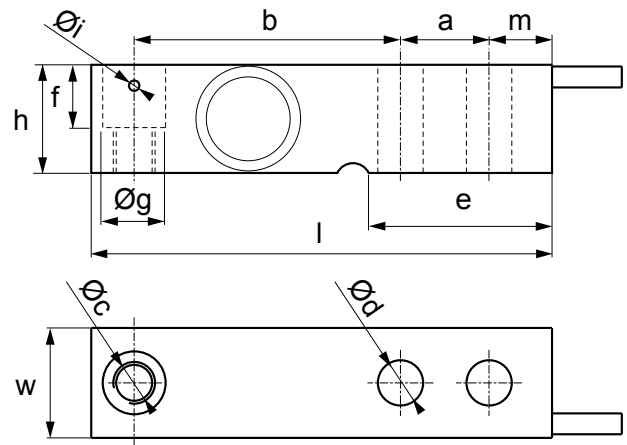

Version codes

Max (kg)	l (mm)	w (mm)	h (mm)	a (mm)	b (mm)	c Ø (mm)	d Ø (mm)	e (mm)	f (mm)	g (mm)	i (mm)	m (mm)	Code
500	132	31,5	31	25,4	76,2	N°1 x M12	N°2 x 13	52,5	18	18	3	18	SBK500C6
1.000													SBK1000C6
2.000													SBK2000C6

ATEX certification



Option	Description	Code
	Optional ATEX version (see www.diniargeo.com for additional details)	CCATEX-1

Technical features

Maximum number of verification intervals	nLC = 6.000
Maximum capacity	2.000 kg
Y value	Vmin = EMax / 15.000
Nominal rated output	2 mV/V ± 0,1 %
Temperature effect on full scale output	0,0007 % / °C
Temperature effect on zero	0,0009 % / °C
Hysteresis	-
Non-linearity	-
Creep at nominal load over 30 minutes	0,012 % F.S.
Input resistance	385 ± 20 Ω
Output resistance	350 ± 5 Ω
Nominal range of excitation voltage	5 - 15 Vdc (Atex version 1 - 12 Vdc)
Combined error	0,008 % F.S.
Insulation resistance	> 5.000 MΩ
Zero balance	± 10 % F.S.
Compensated temperature range	-10 °C / +40 °C
Operating temperature range	-20 °C / +60 °C
Safe overload	150 % F.S.
Breaking load	200 % F.S.
Nominal displacement	-
Repeatability	-
Shielded cable	Ø 5 mm l = 5 m



Main options and accessories (for a complete list visit www.dinargeo.com)

Mounting kits	Material	Max capacity (kg)	Max lift-off force (kN)	Max side force (kN)	Code	
	Nickel-plated steel	2.500 kg	10	-	KSBC2	
	Galvanised steel	2.500 kg	-	-	KSBN2	
	Stainless steel	2.500 kg	10	-	KSBX2	
	Stainless steel	2.000 kg	-	-	KSB2H	

Option	Description	Code	
	Galvanised stay rod with ball-and-socket joints. Max 100 kN. For proper installation, 2xLNKST are needed.	LNK2635	
	Single plate for stay rod. Fitted with fixing screw. For proper installation, LNK2635 and a second LNKST are needed.	LNKST	
	Grounded cable for weighing kit. 16 mm ² cable, 13 mm eyelets.	GNDC	

This kit is designed to allow the correct functioning of the cells and the requested weighing accuracy, within the limits described into the technical manual.

Foot	Material	Load cell compatibility	Threading	Code	
	Stainless steel	For load cells up to 2.500 kg	M12 x 43 mm	SBFI-1	
	Stainless steel	For load cells up to 2.500 kg	M12 x 45 mm	KSB2FI-1	
	Nickel-plated steel	For load cells up to 2.500 kg	M12 x 45 mm	SBFA	
Bushes	Material	Foot compatibility	Threading	Code	
	Stainless steel	M12 bush	M12 x 25 mm	BLKM12I	

Joints	Material	Description	Threading	Code	
	Stainless steel / Rubber	Elastic joint for load cells up to 2.500 kg	M12 x 32 mm	AVM12	
	Stainless steel	Ball joint perfect to improve weighing performance	M12 x 32 mm	SBJ12	

Base plates	Material	Description	Hole size	Code	
	Stainless steel	Thickness for load cells up to 2.500 kg. Size (l x w x h): 55 x 30 x 5 mm.	N° 2 x ø 13 mm	BPSB5	
	Stainless steel	Thickness for load cells up to 2.500 kg. Size (l x w x h): 55 x 30 x 3 mm.	N° 2 x ø 13 mm	BPSB3	

KSBC | MOUNTING KIT



Mounting kits for SBT / SBK / SBX series Shear Beam load cells up to 2.500 kg. Suitable for weighing hoppers, tanks and platforms.

NICKEL
PLATED
STEEL

Version codes

Mounting kits	Material	Weight (kg)	Max capacity (kg)	Max lift-off force (kN)	Max side force (kN)	Code	
	Nickel-plated steel	4,7	Up to 2.500 kg (Load cell capacity)	10	-	KSBC2 (Load cell not included)	

Technical features

Construction in nickel-plated steel



Anti-tipping system

Locking/bypass system for easy transport and maintenance

Higher plate with ball joint, for optimal weighing precision

Overload protection nuts

Main options and accessories (for a complete list visit www.diniargeo.com)

Option	Description	Code	
	Galvanised stay rod with ball-and-socket joints. Max 100 kN. For proper installation, 2xLNKST are needed.	LNK2635	
	Single plate for stay rod. Fitted with fixing screw. For proper installation, LNK2635 and a second LNKST are needed.	LNKST	
	Grounded cable for weighing kit. 16 mm ² cable, 13 mm eyelets.	GNDC	

This kit is designed to allow the correct functioning of the cells and the requested weighing accuracy, within the limits described into the technical manual.

Technical drawing (mm)

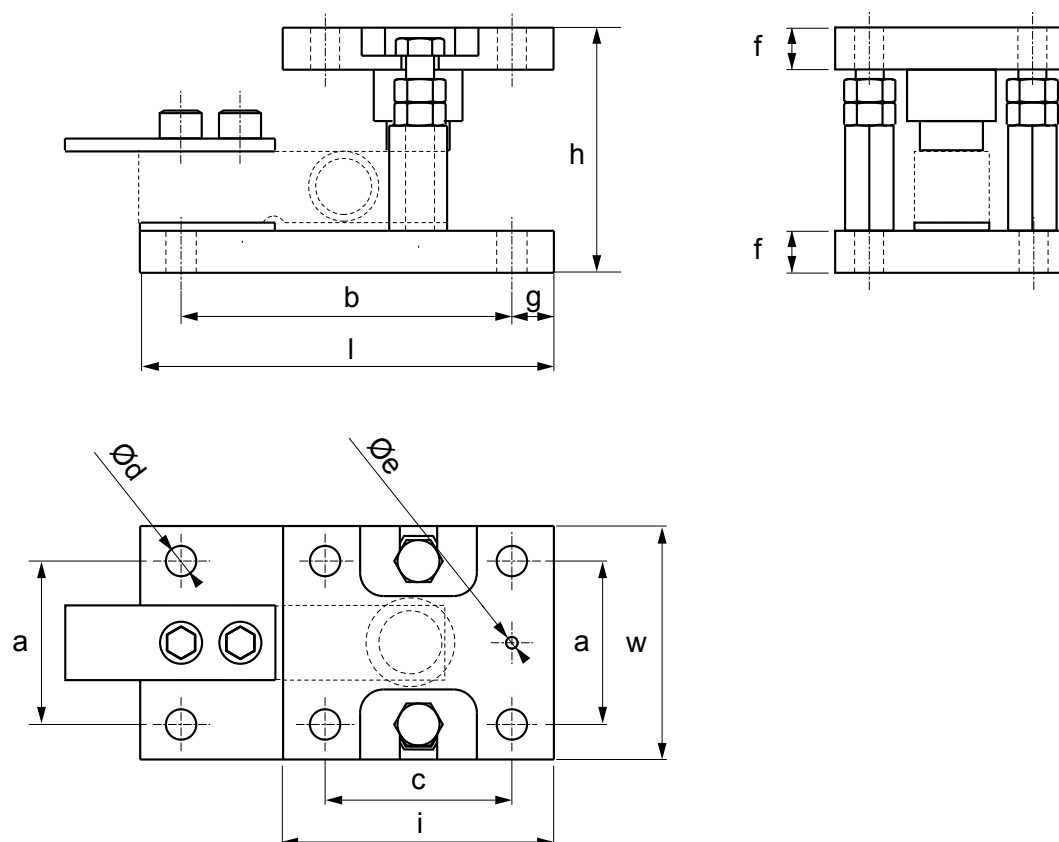

Max (kg)	l (mm)	w (mm)	h (mm)	a (mm)	b (mm)	c (mm)	d Ø (mm)	e Ø (mm)	f (mm)	g (mm)	i (mm)	Code
2.500	175	100	105	70	140	80	N°8 x 13	N°2 x 5	18	17,5	116	KSBC2

KSBN | MOUNTING KIT



Mounting kits for SBX / SBK series Shear Beam load cells up to 2.500 kg. Suitable for weighing hoppers, tanks and platforms.



Version codes

Mounting kits	Material	Weigh (kg)	Max capacity (kg)	Max lift-off force (kN)	Max side force (kN)	Code	
	Galvanised steel	5,2	Up to 2.500 kg (Load cell capacity)	-	-	KSBN2 (Load cell not included)	



ATEX certification

Option	Description	Code	
	ATEX declaration for the PLATFORM / LOAD CELL ASSEMBLY KIT (for load cell ATEX declaration see CCATEX code). Option to be offered only if the platform is ordered without the indicator, otherwise refer to the available certifications for the chosen weight indicator.	DCATEXMECH	

Technical features

Construction in galvanised steel
Height adjustment for correct leveling
Mechanical compensation of thermal swellings and transversal forces
Upper plate with ball joint for excellent measuring accuracy
ATEX version available for zones 1&21, 2&22

Main options and accessories *(for a complete list visit www.diniargeo.com)*

Option	Description	Code	
	Galvanised stay rod with ball-and-socket joints. Max 100 kN. For proper installation, 2xLNKST are needed.	LNK2635	
	Single plate for stay rod. Fitted with fixing screw. For proper installation, LNK2635 and a second LNKST are needed.	LNKST	
	Grounded cable for weighing kit. 16 mm ² cable, 13 mm eyelets.	GNDC	

This kit is designed to allow the correct functioning of the cells and the requested weighing accuracy, within the limits described into the technical manual.

Technical drawing (mm)

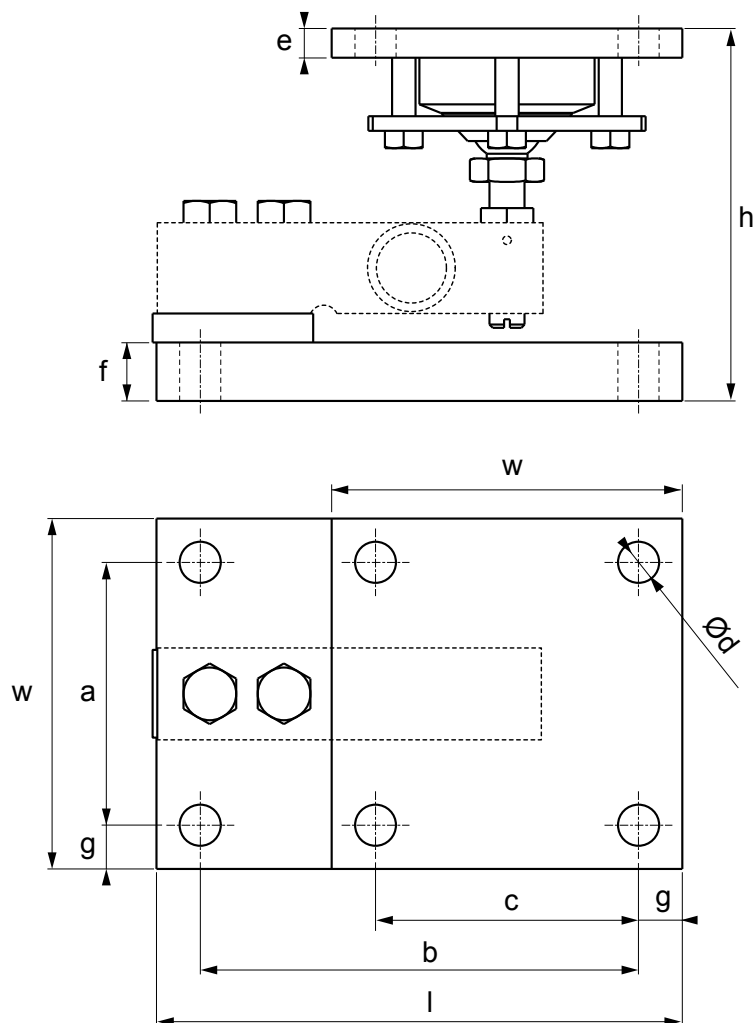

Max (kg)	l (mm)	w (mm)	h (mm)	a (mm)	b (mm)	c (mm)	d Ø (mm)	e (mm)	f (mm)	g (mm)	Code
2.500	180	120	127,5	90	150	90	N°8 x 14	10	20	15	KSBN2

KSBX | MOUNTING KIT



Mounting kits for SBT / SBX / SBK series Shear Beam load cells up to 2.500 kg. Suitable for weighing hoppers, tanks and platforms.



Version codes

Mounting kits	Material	Weight (kg)	Max capacity (kg)	Max lift-off force (kN)	Max side force (kN)	Code	
	Stainless steel	4,7	Up to 2.500 kg (Load cell capacity)	10	-	KSBX2 (Load cell not included)	



ATEX certification

Option	Description	Code	
	ATEX declaration for the PLATFORM / LOAD CELL ASSEMBLY KIT (for load cell ATEX declaration see CCATEX code). Option to be offered only if the platform is ordered without the indicator, otherwise refer to the available certifications for the chosen weight indicator.	DCATEXMECH	

Technical features

Construction in stainless steel AISI 304, with electropolished finishing, for better resistance to external agents
Anti-tipping system
Locking/bypass system for easy transport and maintenance
Overload protection nut
Higher plate with configurable system "lock, "side" or "free"
Height regulation for a correct levelling of the structure
Oscillating joint
Simplified base fixing with 3 holes, or complete with 4 holes
ATEX version available, for zones 1&21, 2&22

Main options and accessories (for a complete list visit www.diniargeo.com)

Option	Description	Code	
	Galvanised stay rod with ball-and-socket joints. Max 100 kN. For proper installation, 2xLNKST are needed.	LNK2635	
	Single plate for stay rod. Fitted with fixing screw. For proper installation, LNK2635 and a second LNKST are needed.	LNKST	
	Grounded cable for weighing kit. 16 mm ² cable, 13 mm eyelets.	GNDC	

This kit is designed to allow the correct functioning of the cells and the requested weighing accuracy, within the limits described into the technical manual.

Technical drawing (mm)

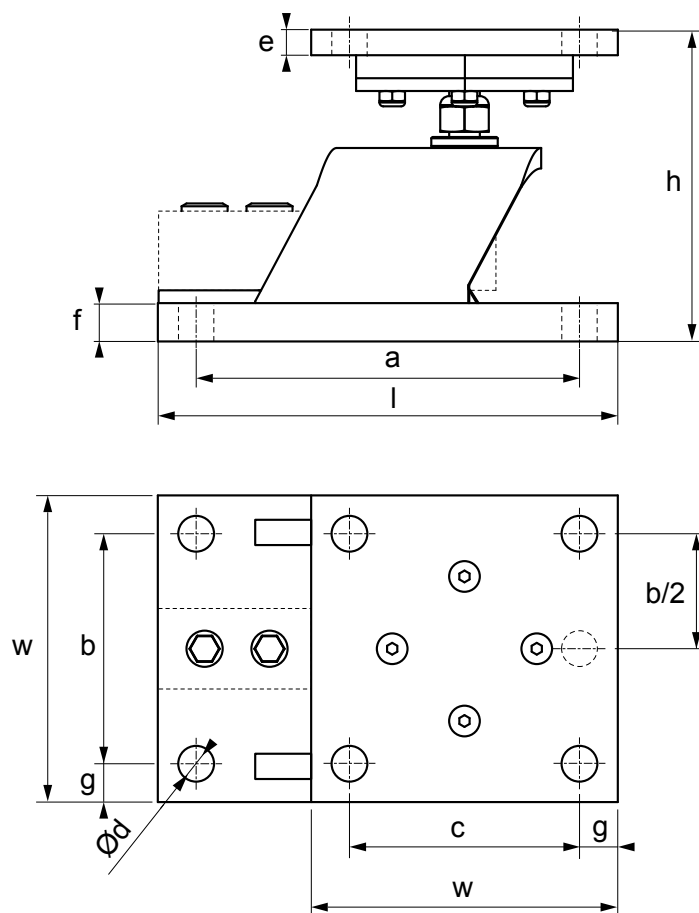

Max (kg)	l (mm)	w (mm)	h (mm)	a (mm)	b (mm)	c (mm)	d \varnothing (mm)	e (mm)	f (mm)	g (mm)	Code
2.500	180	120	122	150	90	90	N°9 x 14	10	15	15	KSBX2

RSBT | DOUBLE SHEAR BEAM

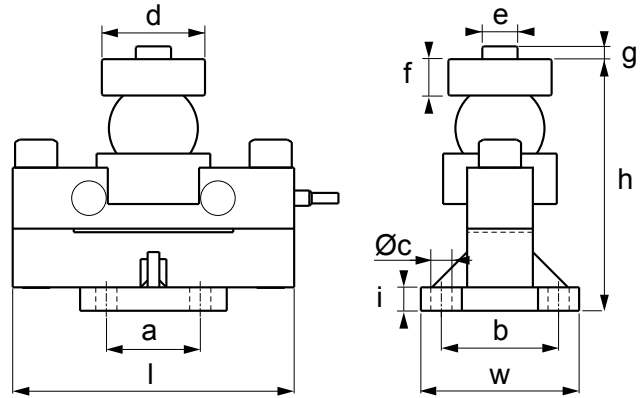

Version codes

Max (kg)	l (mm)	w (mm)	h (mm)	a (mm)	b (mm)	c Ø (mm)	d Ø (mm)	e Ø (mm)	f (mm)	g (mm)	i (mm)	Code
25.000	240	135	225,5	80	100	N°4 x 18	86	28	29	11	20	RSBT25C3
30.000												RSBT30C3
40.000	240	135	225,5	80	100	N°4 x 18	86	28	29	11	20	RSBT40C3

ATEX certification

Option	Description	Code
	Optional ATEX version (see www.diniargeo.com for additional details)	CCATEX-1

Technical features

Maximum number of verification intervals	nLC = 3.000
Maximum capacity	40.000 kg
Y value	Vmin = EMax / 10.000
Nominal rated output	2 mV/V ± 0,2 %
Temperature effect on full scale output	0,0014 % / °C
Temperature effect on the zero	± 0,0017 % / °C
Creep at nominal load over 30 minutes	0,02 % F.S.
Input resistance	750 Ω
Output resistance	700 ± 7 Ω
Nominal range of excitation voltage	5 - 18 Vdc
Insulation resistance	> 5.000 MΩ
Zero balance	± 1,5 % F.S.
Compensated temperature range	-10 °C / +40 °C
Operating temperature range	-35 °C / +65 °C
Safe overload	> 150 % F.S.
Breaking load	300 % F.S.
Shielded cable	Ø 6 mm l = 15 m

DSBI | DOUBLE SHEAR BEAM

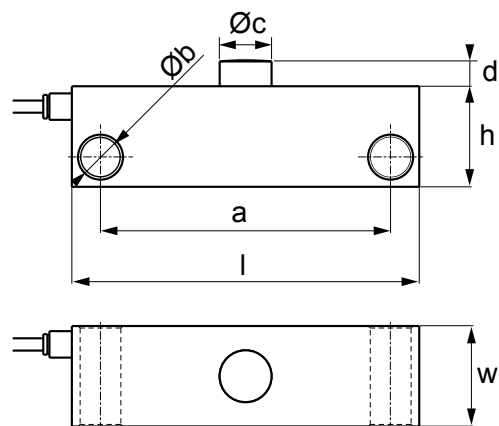

Version codes

Max (kg)	l (mm)	w (mm)	h (mm)	a (mm)	b Ø (mm)	c Ø (mm)	d (mm)	Code	
10.000	170	49,2	49,2	142	N°2 x 20	25,4	12,7	DSBI10	
20.000								DSBI20	
30.000								DSBI30	

ATEX certification

Option	Description	Code	
	Optional ATEX version (see www.diniargeo.com for additional details)	CCATEX-1	

Technical features

Maximum number of verification intervals	nLC = 4.000
Maximum capacity	30.000 kg
Y value	Vmin = EMax / 10.000
Nominal rated output	2 mV/V ± 0,1 %
Temperature effect on full scale output	0,00097 % / °C
Temperature effect on the zero	0,00116 % / °C
Hysteresis	± 0,015 % F.S.
Non-linearity	± 0,015 % F.S.
Creep at nominal load over 4 hours	< 0,02 % F.S.
Input resistance	700 ± 10 Ω
Output resistance	700 ± 10 Ω
Nominal range of excitation voltage	5 - 15 Vdc
Insulation resistance	> 5.000 MΩ
Zero balance	± 2 % F.S.
Compensated temperature range	-10 °C / +40 °C
Operating temperature range	-30 °C / +85 °C
Safe overload	150 % F.S.
Breaking load	300 % F.S.
Shielded cable	Ø 5 mm l = 15 m

Main options and accessories (for a complete list visit www.diniargeo.com)

Mounting kits	Material	Max capacity (kg)	Max lift-off force (kN)	Max side force (kN)	Code	
	Stainless steel	Up to 30.000 kg	-	-	KDSBN (Load cell not included)	

KDSBN | MOUNTING KIT



Mounting kits for DSBI series Double Shear Beam load cells up to 30.000 kg. Suitable for weighing large capacity hoppers, tanks and silos.



Version codes

Mounting kits	Material	Weight (kg)	Max capacity (kg)	Max lift-off force (kN)	Max side force (kN)	Code	
	Stainless steel	7,3	Up to 30.000 kg (Load cell capacity)	-	-	KDSBN (Load cell not included)	



ATEX certification

Option	Description	Code	
	ATEX declaration for the PLATFORM / LOAD CELL ASSEMBLY KIT (for load cell ATEX declaration see CCATEX code). Option to be offered only if the platform is ordered without the indicator, otherwise refer to the available certifications for the chosen weight indicator.	DCATEXMECH	

Technical features

Construction in stainless steel AISI 304
Anti-tipping system
Locking/bypass system for easy transport and maintenance
Overload protection nuts
Centering plate/electrostatic bypass
Great resistance to lateral forces
Locking nuts to maintain the raised position simplify the installation and the removal of the load cell
ATEX version available for zones 1&21, 2&22

Main options and accessories (for a complete list visit www.diniargeo.com)

Option	Description	Code	
	Galvanised stay rod with ball-and-socket joints. Max 100 kN. For proper installation, 2xLNKST are needed.	LNK2635	
	Single plate for stay rod. Fitted with fixing screw. For proper installation, LNK2635 and a second LNKST are needed.	LNKST	
	Grounded cable for weighing kit. 16 mm ² cable, 13 mm eyelets.	GNDC	

This kit is designed to allow the correct functioning of the cells and the requested weighing accuracy, within the limits described into the technical manual.

Technical drawing (mm)

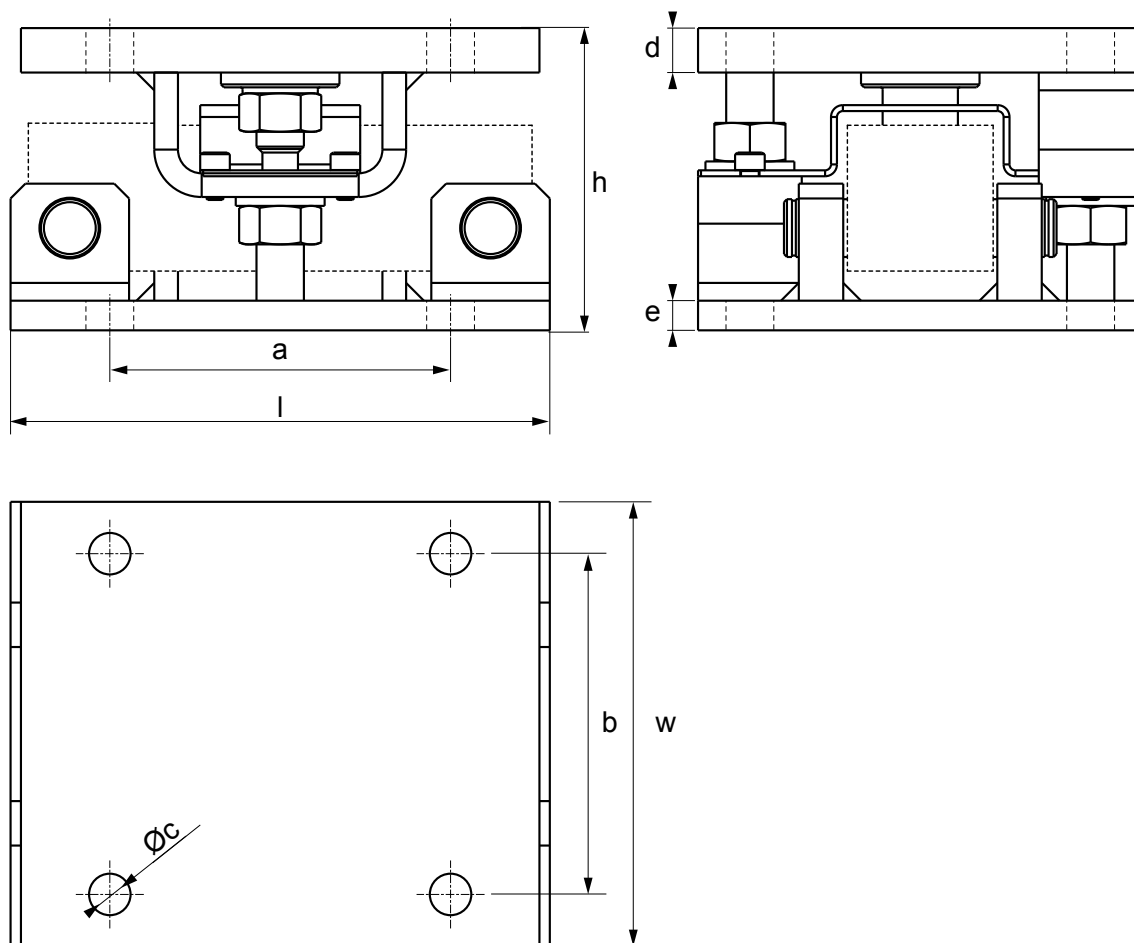

Max (kg)	l (mm)	w (mm)	h (mm)	a (mm)	b (mm)	c Ø (mm)	d (mm)	e (mm)	Code
30.000	182	150	102	115	115	N°8 x 14	15	10	KDSBN

STU 1K | TENSION

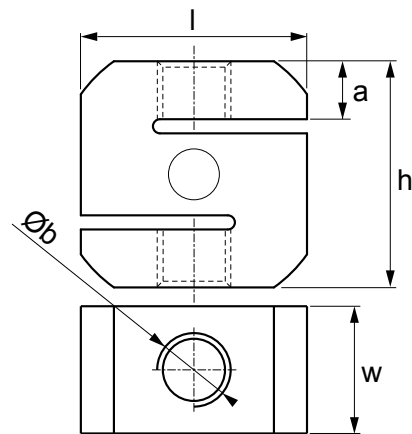



Version codes

Max (kg)	l (mm)	w (mm)	h (mm)	a (mm)	b Ø (mm)	Code	
2.000	80	45	80	20,5	N°2 x M16	STU2000-1KD	
5.000	80	45	80	20,5	N°2 x M24	STU5000-1KD	
8.000						STU8000-1KD	
10.000	80	52	80	20,5	N°2 x M24	STU10000-1KD	

Technical features

Maximum number of verification intervals	nLC = 3.000
Maximum capacity	10.000 kg
Y value	-
Nominal rated output	2 mV/V ± 0,1 %
Temperature effect on full scale output	0,02 % F.S. / 10°C
Temperature effect on zero	0,02 % F.S. / 10°C
Hysteresis	± 0,03 % F.S.
Non-linearity	± 0,03 % F.S.
Creep at nominal load over 30 minutes	± 0,03 % F.S.
Input resistance	1000 ± 20 Ω
Output resistance	1000 ± 20 Ω (Compression) / ± 5 Ω (Tension)
Nominal range of excitation voltage	5 - 15 Vdc
Insulation resistance	> 5.000 MΩ
Zero balance	± 1 % F.S.
Compensated temperature range	-10 °C / +50 °C
Operating temperature range	-20 °C / +60 °C
Safe overload	120 % F.S.
Breaking load	300 % F.S.
Repeatability	± 0,02 % F.S.
Shielded cable	Ø 5 mm l = 3 m

Main options and accessories (for a complete list visit www.dinargeo.com)

Option	Description	Threading	Code	
	M16 articulated rod-end ball joint. Maximum lifting capacity 2.000 kg.	M16	RBJM16	
	M16 clevis fitted with pin, to be combined with RBJM16.	M16	CLVM16	

Code	d (mm)	g (mm)	l ₁ (mm) min.	d ₂ (mm)	h (mm)	l ₂ (mm)	b (mm)
RBJM16	17	M16	36	46	69	92	14

Code	d ₁ (mm)	g (mm)	a ₁ (mm)	a ₂ (mm)	b ₁ (mm)	d ₂ (mm)	d ₃ (mm)	l ₁ (mm)	l ₂ (mm)	l ₂ (mm) max. var.
CLVM16	16	32	32	32	12	M16	26	83	64	0,4

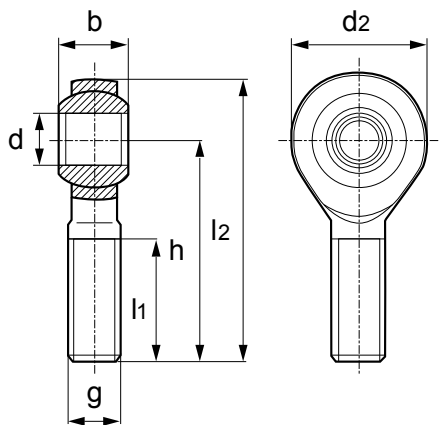
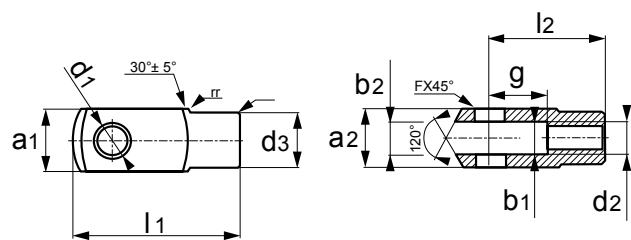
**RBJ****CLV**

STFC | TENSION

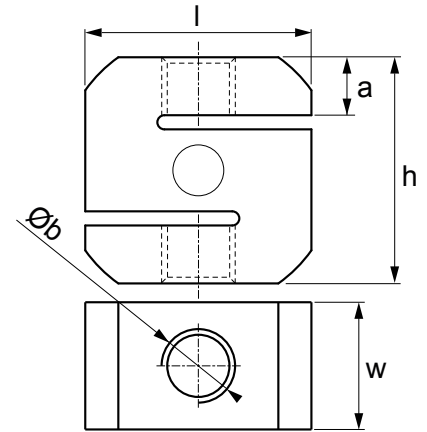

Version codes

Max (kg)	l (mm)	w (mm)	h (mm)	a Ø (mm)	b Ø (mm)	Code	
2.000	80	42	80	20	N°2 x M16	STFC2000	
5.000	80	42	80	20	N°2 x M24	STFC5000	
10.000	80	52	80	20	N°2 x M24	STFC10000	





ATEX certification

Option	Description	Code
	Optional ATEX version (see www.diniargeo.com for additional details)	CCATEX-1

Technical features

Maximum number of verification intervals	nLC = 3.000
Maximum capacity	10.000 kg
Y value	Vmin = EMax / 10.000
Nominal rated output	2 mV/V ± 0,1 %
Temperature effect on full scale output	0,02 % / °C
Temperature effect on zero	0,02 % / °C
Hysteresis	± 0,02 % F.S.
Non-linearity	± 0,02 % F.S.
Creep at nominal load over 4 hours	0,03 % F.S.
Input resistance	1.000 ± 110 Ω
Output resistance	1.000 ± 10 Ω
Nominal range of excitation voltage	5 - 15 Vdc
Insulation resistance	> 5.000 MΩ
Zero balance	± 2 % F.S.
Compensated temperature range	-10 °C / +40 °C
Operating temperature range	-30 °C / +85 °C
Safe overload	150 % F.S.
Breaking load	300 % F.S.
Repeatability	0,01 % F.S.
Shielded cable	Ø 5 mm l = 5 m

Main options and accessories (for a complete list visit www.dinargeo.com)

Option	Description	Threading	Code	
	M16 articulated rod-end ball joint. Maximum lifting capacity 2.000 kg.	M16	RBJM16	
	M16 clevis fitted with pin, to be combined with RBJM16.	M16	CLVM16	
	M24 articulated rod-end ball joint. Maximum lifting capacity 5.000 kg.	M24	RBJM24	
	M24 clevis fitted with pin, to be combined with RBJM24.	M24	CLVM24-1	

Code	d (mm)	g (mm)	l ₁ (mm) min.	d ₂ (mm)	h (mm)	l ₂ (mm)	b (mm)
RBJM16	17	M16	36	46	69	92	14
RBJM24	25	M24	53	64	94	126	20

Code	d ₁ (mm)	g (mm)	a ₁ (mm)	a ₂ (mm)	b ₁ (mm)	d ₂ (mm)	d ₃ (mm)	l ₁ (mm)	l ₂ (mm)	l ₂ (mm) max. var.
CLVM16	16	32	32	32	12	M16	26	83	64	0,4
CLVM24	25	50	50	50	25	M24	42	132	100	0,4

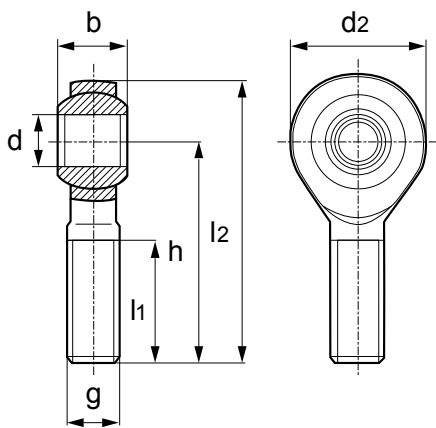
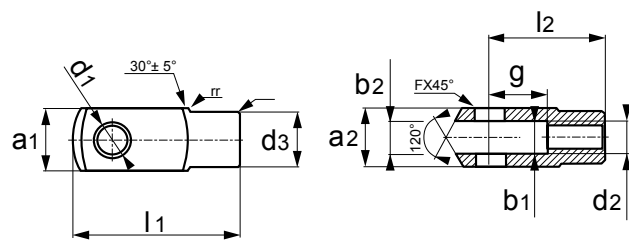
**RBJ****CLV**

SL | TENSION

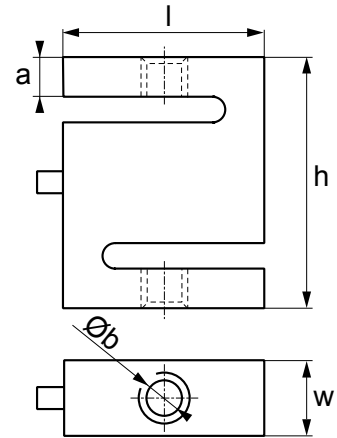



Version codes

Max (kg)	l (mm)	w (mm)	h (mm)	a (mm)	b Ø (mm)	Code
15	51	13	64	10,5	N°2 x M8	SL15
30						SL30
50						SL50
100	51	19	76	13,5	N°2 x M12	SL100
300						SL300
500						SL500
1.000	54	25,4	76	13,5	N°2 x M12	SL1000

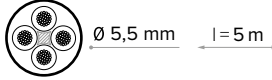
Technical features

Maximum number of verification intervals	-
Maximum capacity	1.000 kg
Y value	-
Nominal rated output	2 mV/V ± 10 %
Temperature effect on full scale output	0,02 % / °C
Temperature effect on zero	0,02 % / °C
Hysteresis	0,02 % F.S.
Non-linearity	0,02 % F.S.
Creep at nominal load over 4 hours	0,03 % F.S.
Input resistance	381 ± 10 Ω
Output resistance	350 ± 3 Ω
Nominal range of excitation voltage	5 - 15 Vdc
Insulation resistance	> 5.000 MΩ
Zero balance	± 2 % F.S.
Compensated temperature range	-10 °C / +40 °C
Operating temperature range	-30 °C / +85 °C
Safe overload	150 % F.S.
Breaking load	300 % F.S.
Repeatability	0,01 % F.S.
Shielded cable	

Main options and accessories (for a complete list visit www.dinargeo.com)

Option	Description	Threading	Code	
	M8 articulated rod-end ball joint. Maximum lifting capacity 600 kg. For load cells up to 50 kg.	M8	RBJM8	
	M8 clevis fitted with pin, to be combined with RBJM8. For load cells up to 50 kg.	M8	CLVM8	
	M12 articulated rod-end ball joint. Maximum lifting capacity 1.000 kg. For load cells from 100 to 1.000 kg.	M12	RBJM12	
	M12 clevis fitted with pin, to be combined with RBJM12. For load cells from 100 to 1.000 kg.	M12	CLVM12	

Code	d (mm)	g (mm)	l ₁ (mm) min.	d ₂ (mm)	h (mm)	l ₂ (mm)	b (mm)
RBJM8	8	M8	22	24	42	54	8
RBJM12	12	M12	28	34	54	71	10

Code	d ₁ (mm)	g (mm)	a ₁ (mm)	a ₂ (mm)	b ₁ (mm)	d ₂ (mm)	d ₃ (mm)	l ₁ (mm)	l ₂ (mm)	l ₂ (mm) max. var.
CLVM8	8	16	16	16	8	M8	14	42	32	0,4
CLVM12	12	24	24	24	12	M12	20	62	48	0,4

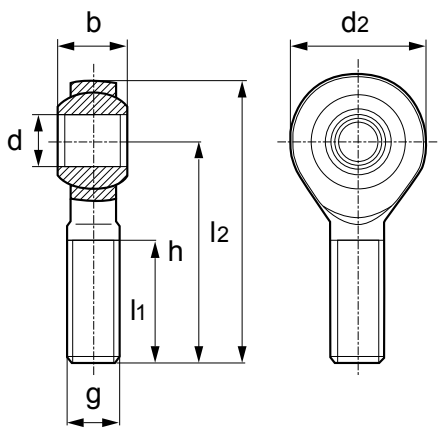
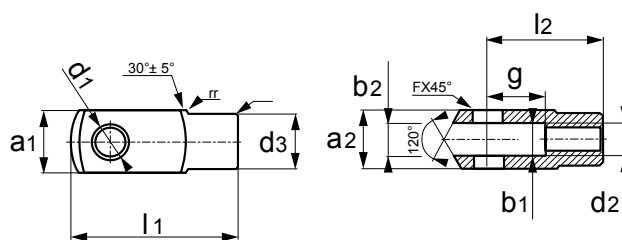
**RBJ****CLV**

CPX | COMPRESSION

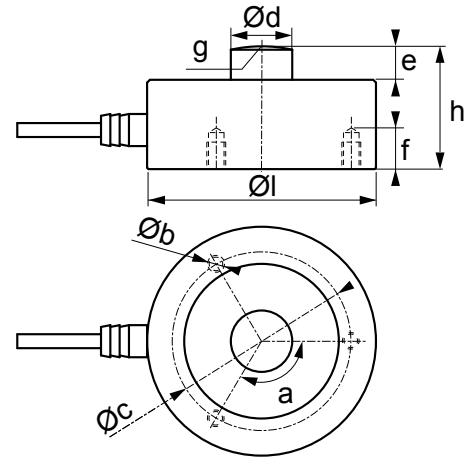



Version codes

Max (kg)	l Ø (mm)	h (mm)	a (°)	b Ø (mm)	c Ø (mm)	d Ø (mm)	e (mm)	f (mm)	g (mm)	Code
250	82	44	120°	3 x M8	68	22	12	21	R120	CPX250
500										CPX500
1.000										CPX1000
2.500										CPX2500
5.000										CPX5000
7.500										CPX7500
10.000										CPX10000
12.500										CPX12500
15.000	100	48,5	120°	3 x M10	80	28	13,5	24	R120	CPX15000
30.000	126	54	120°	3 x M12	90	35	14	30	R120	CPX30000
50.000	165	80	120°	3 x M16	130	60	20	28	R300	CPX50000
100.000										CPX100000
Up to 1.000.000	-	-	-	-	-	-	-	-	-	Upon request







Technical features



Maximum number of verification intervals	nLC = 3.000
Maximum capacity	100.000 kg
Y value	Vmin = EMax / 10.000
Nominal rated output	2 mV/V ± 0,5 %
Temperature effect on full scale output	0,02 % / 10 °C
Temperature effect on zero	0,02 % / 10 °C
Hysteresis	0,05 % F.S.
Non-linearity	0,05 % F.S.
Creep at nominal load over 30 minutes	0,02 % F.S.
Input resistance	750 ± 10 Ω
Output resistance	700 ± 5 Ω
Nominal range of excitation voltage	5 - 15 Vdc
Insulation resistance	> 5.000 MΩ
Zero balance	± 1 % F.S.
Compensated temperature range	-10 °C / +50 °C
Operating temperature range	-20 °C / +60 °C
Safe overload	120 % F.S.
Breaking load	300 % F.S.
Repeatability	0,02 % F.S.
Shielded cable	CPX 250 ... 5.000 kg:
	CPX 7.500 ... 100.000 kg:

ATEX certification

Option	Description	Code	
	Optional ATEX version (see www.diniargeo.com for additional details)	CCATEX-1	
	IP69K version for one load cell	IP69KLC	

Main options and accessories *(for a complete list visit www.diniargeo.com)*

Mounting kits	Material	UNI CE 1090	Max load cell capacity (kg)	Max lift-off force (kN)	Max side force (kN)	Code	
	Nickel-plated steel	-	Up to 12.500 kg	45	25	KCPN10A (Load cell not included)	
	Stainless steel	-	Up to 12.500 kg	45	25	KCPN10 (Load cell not included)	
	Stainless steel	•	Up to 12.500 kg	45	25	KCPN10PRO (Load cell not included)	
	Stainless steel	-	15.000 kg	45	25	KCPN15 (Load cell not included)	
	Stainless steel	-	30.000 kg	45	30	KCPN30 (Load cell not included)	
	Zinc-plated steel	•	30.000 kg	130	100	KCP50 (Load cell not included)	
	Zinc-plated steel	•	50.000 / 100.000 kg	400	200	KCP100H (Load cell not included)	
			Up to 1.000.000 kg	-	-	Upon request	

Option	Description	Code	
	Galvanised stay rod with ball-and-socket joints. Max 100 kN. For proper installation, 2xLNKST are needed.	LNK2635	
	Single plate for stay rod. Fitted with fixing screw. For proper installation, LNK2635 and a second LNKST are needed.	LNKST	
	Grounded cable for weighing kit. 16 mm ² cable, 13 mm eyelets.	GNDC	

This kit is designed to allow the correct functioning of the cells and the requested weighing accuracy, within the limits described into the technical manual.

- As standard

CPA | COMPRESSION

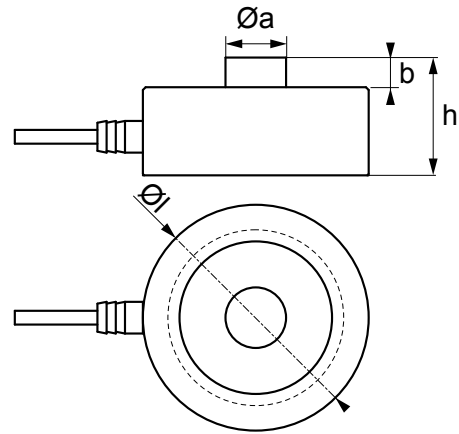

Version codes

Max (kg)	l Ø (mm)	h (mm)	a Ø (mm)	b (mm)	Code	
150	82	44	22	12	CPA150	
300					CPA300	
500					CPA500	
1.000					CPA1000	
2.000					CPA2000	
3.000					CPA3000	
5.000					CPA5000	
7.000	128	54	35	14	CPA7000	
10.000					CPA10000	
20.000					CPA20000	
30.000					CPA30000	
50.000	-	-	-	-	CPA50000	
Up to 1.000.000					Upon request	



Technical features







Maximum number of verification intervals	nLC = 3.000
Maximum capacity	50.000 kg
Y value	Vmin = EMax / 10.000
Nominal rated output	2 mV/V ± 0,1 %
Temperature effect on full scale output	0,0013 % / °C
Temperature effect on zero	0,001 % / °C
Hysteresis	0,015 % F.S.
Non-linearity	0,025 % F.S.
Creep at nominal load over 4 hours	0,03 % F.S.
Input resistance	1100 ± 50 Ω
Output resistance	1000 ± 10 Ω
Nominal range of excitation voltage	5 - 15 Vdc
Combined error	-
Insulation resistance	> 5.000 MΩ
Zero balance	± 2 % F.S.
Compensated temperature range	-10 °C / +40 °C
Operating temperature range	-30 °C / +85 °C (* Upon request up to 200 °C)
Storage temperature range	-30 °C / +90 °C
Safe overload	150 % F.S.
Breaking load	300 % F.S.
Repeatability	0,01 % F.S.
Shielded cable	CPA 150 ... 10.000 kg:
	CPA 20.000 ... 50.000 kg:

ATEX certification

Option	Description	Code
	Optional ATEX version (see www.diniargeo.com for additional details)	CCATEX-1

Main options and accessories *(for a complete list visit www.diniargeo.com)*

Option	Description	Code
	Option for high temperatures with compensation up to 200°C and specific cable (for single load cell)	CPAHT
	Option for high temperatures with compensation up to 85°C and standard cable (for single load cell)	CPAHTL

Mounting kits	Material	UNI EN 1090	Max load cell capacity (kg)	Max lift-off force (kN)	Max side force (kN)	Code
	Nickel-plated steel	-	Up to 10.000 kg	45	25	KCPN10A (Load cell not included)
	Stainless steel	-	Up to 10.000 kg	45	25	KCPN10 (Load cell not included)
	Stainless steel	•	Up to 10.000 kg	45	25	KCPN10PRO (Load cell not included)
	Stainless steel	-	15.000 kg	45	25	KCPN15 (Load cell not included)
	Zinc-plated steel	•	50.000 kg	130	100	KCP50 (Load cell not included)
	Zinc-plated steel	-	CPX - 30.000 CPA - From 20.000 to 50.000	130	100	KCP50-NS (Load cell not included)
	Zinc-plated steel	•	CPX - 30.000 CPA - From 20.000 to 50.000	130	100	KCP50-1090-NS (Load cell not included)
			Up to 1.000.000 kg	-	-	Upon request

- As standard

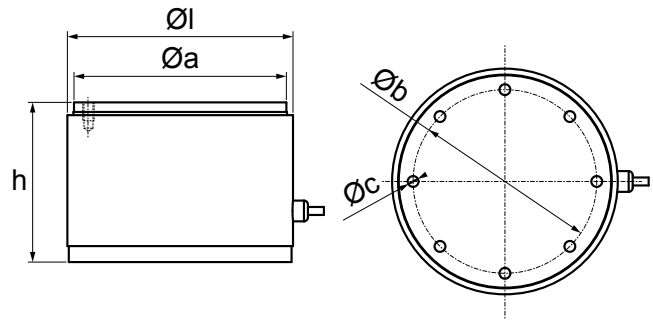

CPH | COMPRESSION







Version codes

Max (kg)	l Ø (mm)	h (mm)	a Ø (mm)	b Ø (mm)	c Ø (mm)	Code	
50.000	141,3	100	133	115	N°16 x M8	CPH50	
100.000						CPH100	
250.000						CPH250	
500.000	168	100	160,5	115	N°24 x M12	CPH500	
800.000	219	200	210	150	N°24 x M20	CPH800	
1.000.000						CPH1000	

Technical features

Maximum number of verification intervals	-
Maximum capacity	1.000.000 kg
Y value	-
Nominal rated output	2 mV/V ± 1 %
Temperature effect on full scale output	0,0013 % / °C
Temperature effect on zero	0,0014 % / °C
Hysteresis	0,15 % F.S.
Non-linearity	0,15 % F.S.
Creep at nominal load over 4 hours	0,05 % F.S.
Input resistance	1050 ± 20 Ω (from 50.000 to 500.000 kg), 1400 ± 20 Ω (from 800.000 to 1.000.000 kg)
Output resistance	1050 ± 20 Ω (from 50.000 to 500.000 kg), 1400 ± 20 Ω (from 800.000 to 1.000.000 kg)
Nominal range of excitation voltage	5 - 15 Vdc
Combined error	-
Insulation resistance	> 5.000 MΩ
Zero balance	± 2 % F.S.
Compensated temperature range	-10 °C / +40 °C
Operating temperature range	-30 °C / +85 °C
Storage temperature range	-30 °C / +90 °C
Safe overload	150 % F.S.
Breaking load	300 % F.S.
Repeatability	0,1 % F.S.
Shielded cable	CPH 50.000 ... 500.000 kg:  Ø 5 mm l = 15 m CPH 800.000 ... 1.000.000 kg:  Ø 5 mm l = 25 m

Main options and accessories (for a complete list visit www.diniargeo.com)

Mounting kits	Material	Max load cell capacity (kg)	Max lift-off force (kN)	Max side force (kN)	Code	
	Stainless steel	Up to 250.000 kg	-	-	KCPXH250 (Load cell not included)	
	Stainless steel	Up to 500.000 kg	-	-	KCPXH500 (Load cell not included)	
	Stainless steel	Up to 800.000 kg	-	-	KCPXH800 (Load cell not included)	
	Stainless steel	Up to 1.000.000 kg	-	-	KCPXH1000 (Load cell not included)	

- As standard
- Optional

KCPNA | MOUNTING KIT



Mounting kits for CPX / CPA series Compression load cells up to 12.500 / 10.000 kg. Suitable for weighing silos, tanks and hoppers.

NICKEL
PLATED
STEEL



Version codes

Mounting kits	Material	Weight (kg)	Max capacity (kg)	Max lift-off force (kN)	Max side force (kN)	Code	
	Nickel-plated steel	5,4	CPX - Up to 12.500 CPA - Up to 10.000	45	25	KCPN10A (Load cell not included)	

Technical features

Construction in nickel-plated steel
Anti-tipping system
Locking/bypass system for easy transport and maintenance
Overload protection nuts
Self-centering connection segment between lower and upper plate
Protection against electrostatic charges
Great resistance to lateral forces
Locking nuts to maintain the raised position simplify the installation and the removal of the load cell
Dummy load cells for liquid weighing

Main options and accessories (for a complete list visit www.diniargeo.com)

Option	Description	Code	
	Galvanised stay rod with ball-and-socket joints. Max 100 kN. For proper installation, 2xLNKST are needed.	LNK2635	
	Single plate for stay rod. Fitted with fixing screw. For proper installation, LNK2635 and a second LNKST are needed.	LNKST	
	Grounded cable for weighing kit. 16 mm ² cable, 13 mm eyelets.	GNDC	

This kit is designed to allow the correct functioning of the cells and the requested weighing accuracy, within the limits described into the technical manual.

Technical drawing (mm)

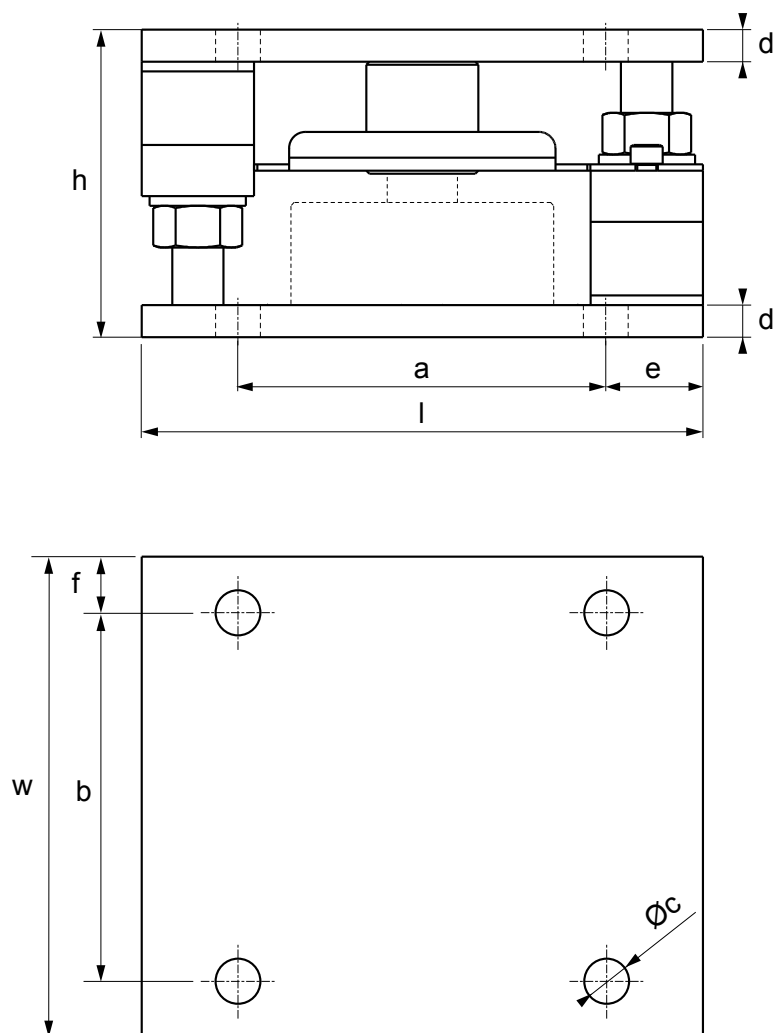

Max (kg)	l (mm)	w (mm)	h (mm)	a (mm)	b (mm)	c \varnothing (mm)	d (mm)	e (mm)	f (mm)	Code
12.500	175	150	96	115	115	N°8 x 14	10	30	17,5	KCPN10A



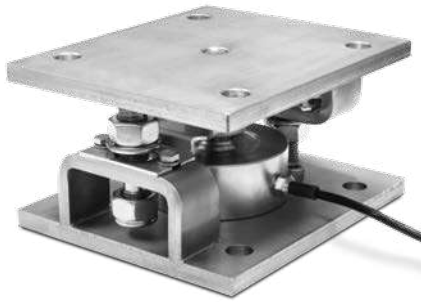

KCPN | MOUNTING KIT



Mounting kits for CPX / CPA series Compression load cells up to 100.000 kg. Suitable for weighing large capacity silos, tanks, hoppers.



Version codes

Mounting kits	Material	UNI EN 1090	Weight (kg)	Max capacity (kg)	Max lift-off force (kN)	Max side force (kN)	Code	
	Stainless steel	-	5,4	CPX - Up to 12.500 CPA - Up to 10.000	45	25	KCPN10 (Load cell not included)	
	Stainless steel	•	5,4	CPX - Up to 12.500 CPA - Up to 10.000	45	25	KCPN10PRO (Load cell not included)	
	Stainless steel	-	5,4	CPX - 15.000	45	25	KCPN15 (Load cell not included)	
	Stainless steel	-	9,4	CPX - 30.000	45	30	KCPN30 (Load cell not included)	
	Stainless steel	-	41,6	CPX - From 50.000 to 100.000	90	40	KCPN100 (Load cell not included)	

ATEX certification

Option	Description	Code	
	ATEX declaration for the PLATFORM / LOAD CELL ASSEMBLY KIT (for load cell ATEX declaration see CCATEX code). Option to be offered only if the platform is ordered without the indicator, otherwise refer to the available certifications for the chosen weight indicator.	DCATEXMECH	

Technical features

Construction in stainless steel AISI 304
Anti-tipping system
Locking/bypass system for easy transport and maintenance
Overload protection nuts
Self-centering connection segment between lower and upper plate
Protection against electrostatic discharges
Great resistance to lateral forces
Locking nuts to maintain the raised position simplify the installation and the removal of the load cell
Dummy load cells for liquid weighing
ATEX version available for zones 1&21, 2&22

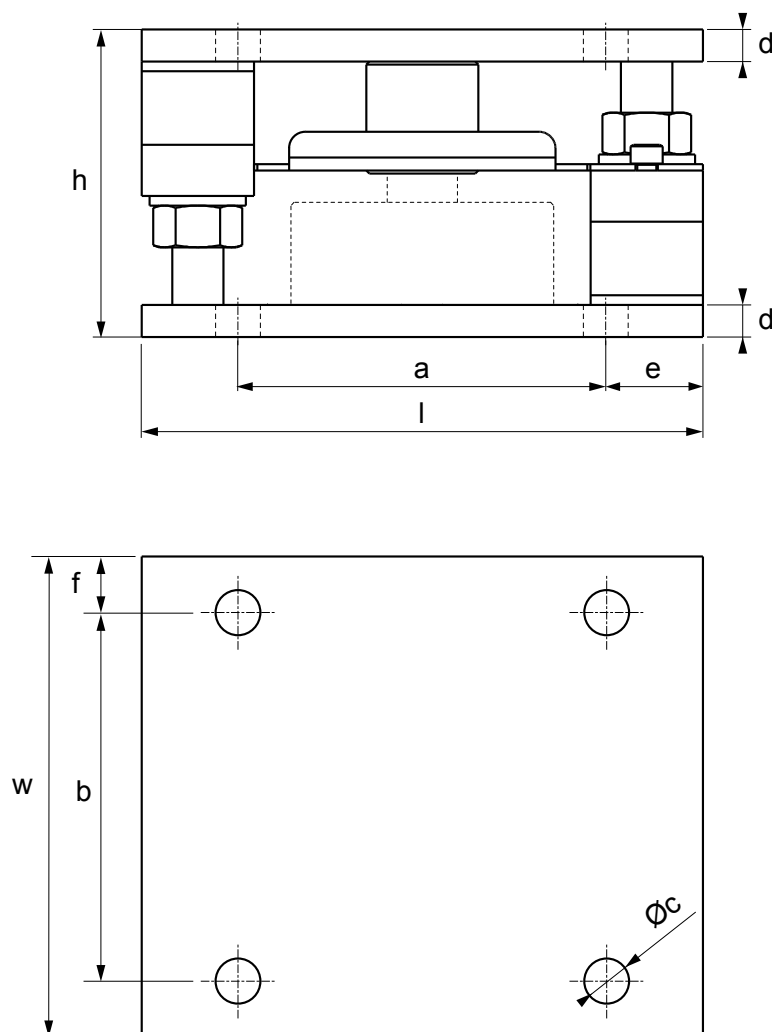

This kit is designed to allow the correct functioning of the cells and the requested weighing accuracy, within the limits described into the technical manual.

Technical drawing (mm)



Max (kg)	l (mm)	w (mm)	h (mm)	a (mm)	b (mm)	c ∅ (mm)	d (mm)	e (mm)	f (mm)	Code
12.500	175	150	96	115	115	N°8 x 14	10	30	17,5	KCPN10
15.000										KCPN10PRO
30.000	230	200	118	160	160	N°8 x 17	10	30	17,5	KCPN15
100.000	320	320	154	250	250	N°8 x 23	20	35	35	KCPN30
										KCPN100

Main options and accessories *(for a complete list visit www.diniargeo.com)*

Option	Description	Code	
	Galvanised stay rod with ball-and-socket joints. Max 100 kN. For proper installation, 2xLNKST are needed.	LNK2635	
	Single plate for stay rod. Fitted with fixing screw. For proper installation, LNK2635 and a second LNKST are needed.	LNKST	
	Grounded cable for weighing kit. 16 mm ² cable, 13 mm eyelets.	GNDC	

KCP50 | MOUNTING KIT



Mounting kits for 30.000 kg CPX and CPA series Compression load cells from 20.000 kg to 50.000 kg. Suitable for weighing large capacity silos, tanks and hoppers.



Version codes

Mounting kits	Material	Weight (kg)	Max capacity (kg)	Max lift-off force (kN)	Max side force (kN)	UNI EN 1090	Code	
	Zinc-plated steel	27	50.000 kg	130	100	•	KCP50 (Load cell not included)	
	Zinc-plated steel	27	CPX - 30.000 CPA - From 20.000 to 50.000	130	100	-	KCP50-NS (Load cell not included)	
	Zinc-plated steel	27	CPX - 30.000 CPA - From 20.000 to 50.000	130	100	•	KCP50-1090-NS (Load cell not included)	

ATEX certification

Option	Description	Code	
	ATEX declaration for the PLATFORM / LOAD CELL ASSEMBLY KIT (for load cell ATEX declaration see CCATEX code). Option to be offered only if the platform is ordered without the indicator, otherwise refer to the available certifications for the chosen weight indicator.	DCATEXMECH	

Technical features

Construction in zinc-plated steel
Anti-tipping system
Locking/bypass system for easy transport and maintenance
Overload protection nuts
Great resistance to lateral forces
Locking nuts to maintain the raised position simplify the installation and the removal of the load cell
Dummy load cells for liquid weighing

Main options and accessories (for a complete list visit www.diniargeo.com)

Option	Description	Code	
	Zinc-plated-steel stay rod with ball-and-socket joints. Max 29 kN.	LNK20	
	Grounded cable for weighing kit. 16 mm ² cable, 13 mm eyelets.	GNDC	

This kit is designed to allow the correct functioning of the cells and the requested weighing accuracy, within the limits described into the technical manual.

Technical drawing (mm)

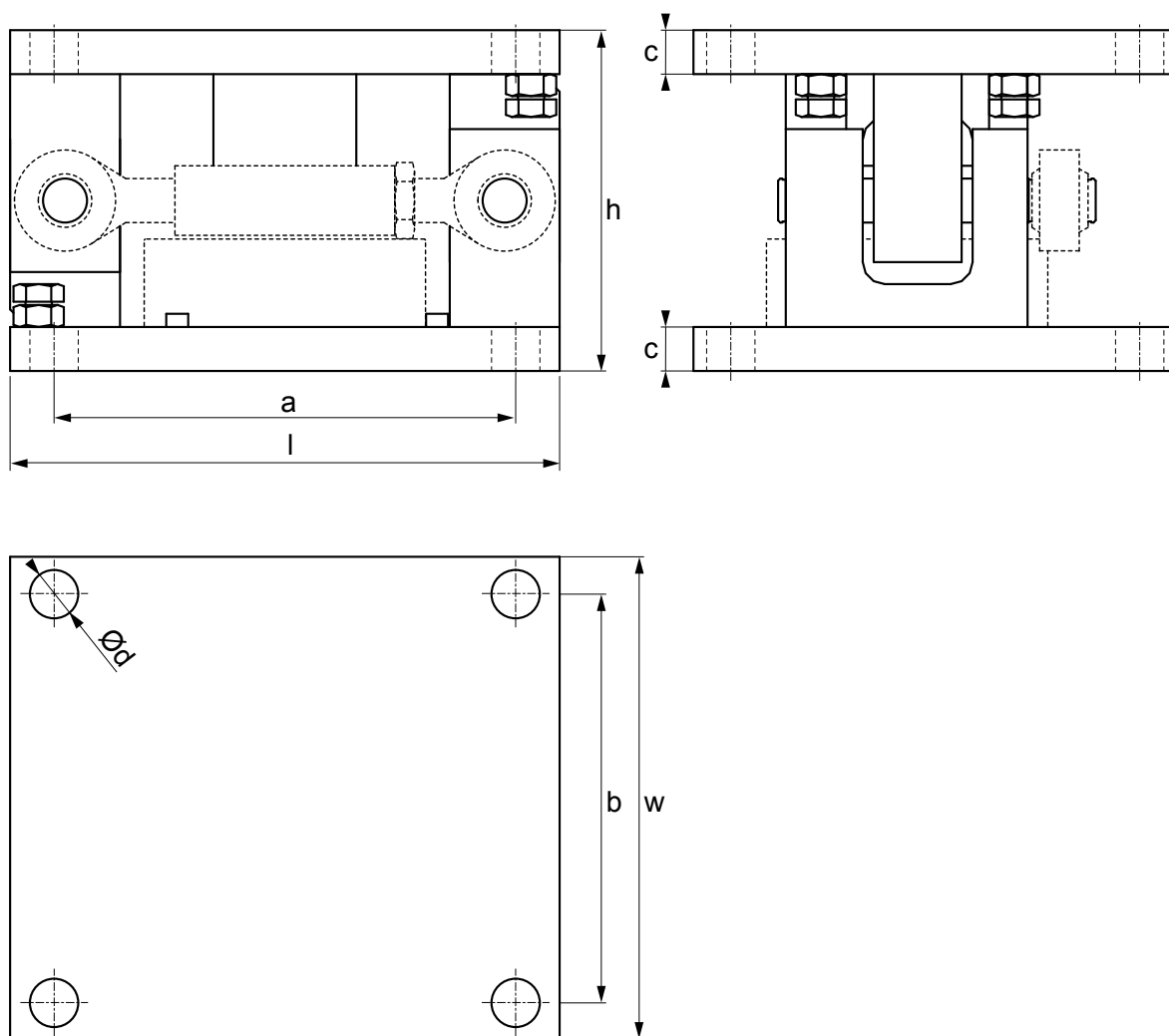



Max (kg)	l (mm)	w (mm)	h (mm)	a (mm)	b (mm)	c (mm)	d Ø (mm)	Code
50.000	250	230	155	210	186	20	22	KCP50

KCP100H | MOUNTING KIT

Mounting kits for CPX series Compression load cells from 50.000 to 100.000 kg. Suitable for weighing large capacity silos, tanks, hoppers.



Version codes

Mounting kits	Material	Weight (kg)	Max capacity (kg)	Max lift-off force (kN)	Max side force (kN)	UNI EN 1090	Code	
	Zinc-plated steel	90	CPX - From 50.000 to 100.000 kg	400	200	-	KCP100H (Load cell not included)	
	Zinc-plated steel	90	CPX - From 50.000 to 100.000 kg	400	200	•	KCP100H-1090 (Load cell not included)	

Technical features

Construction in zinc-plated steel
Double anti-tipping system
Locking/bypass system for easy transport and maintenance
Overload protection nuts
Great resistance to lateral forces
Locking nuts to maintain the raised position simplify the installation and the removal of the load cell
Stainless steel structure available upon request

Main options and accessories *(for a complete list visit www.dinargeo.com)*

Option	Description	Code	
	Grounded cable for weighing kit. 16 mm ² cable, 13 mm eyelets.	GNDC	

This kit is designed to allow the correct functioning of the cells and the requested weighing accuracy, within the limits described into the technical manual.

Technical drawing (mm)

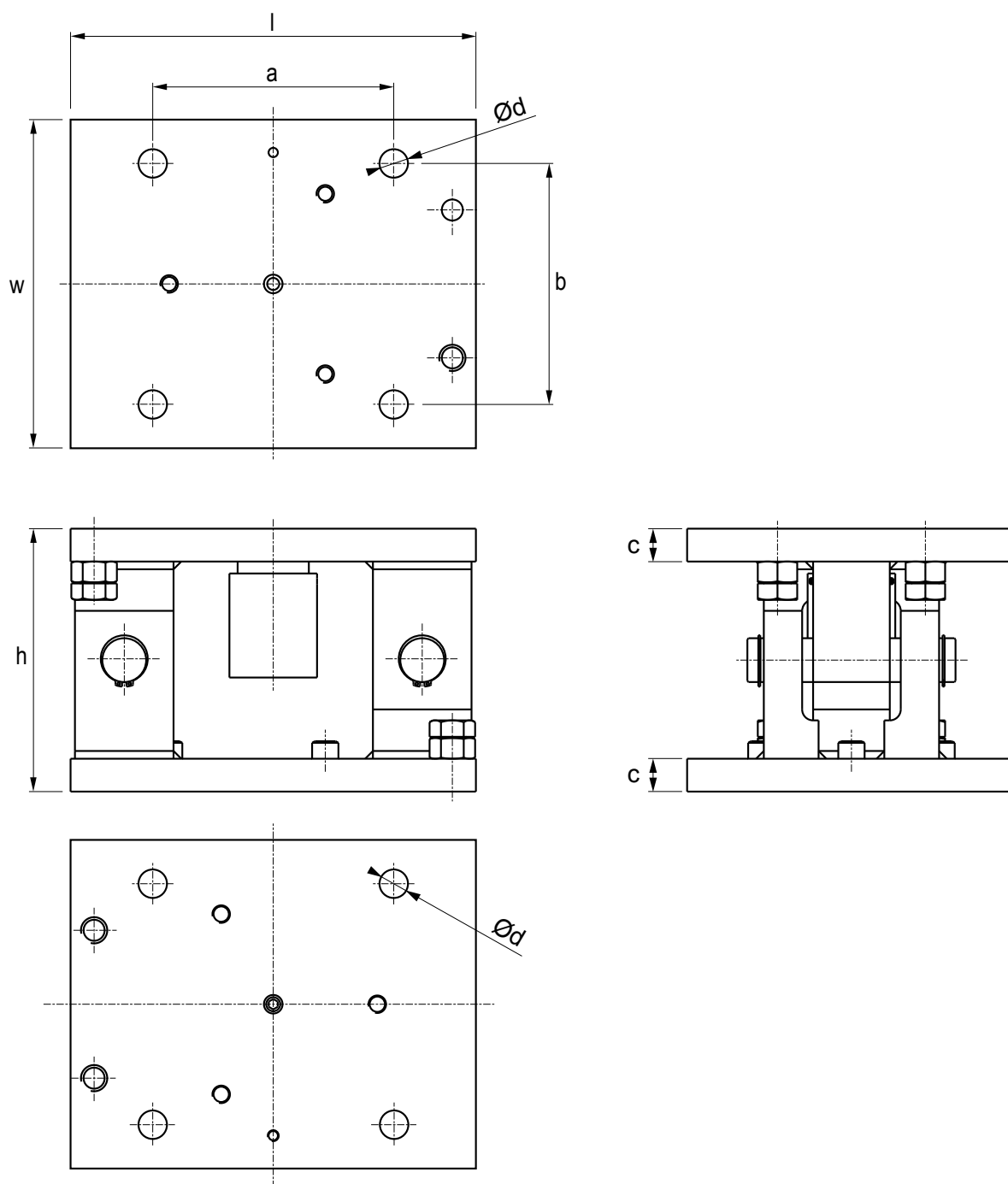

Max (kg)	l (mm)	w (mm)	h (mm)	a (mm)	b (mm)	c (mm)	d Ø (mm)	Code
100.000	370	300	240 / 250	220	220	30	26	KCP100H

RCA | COLUMN

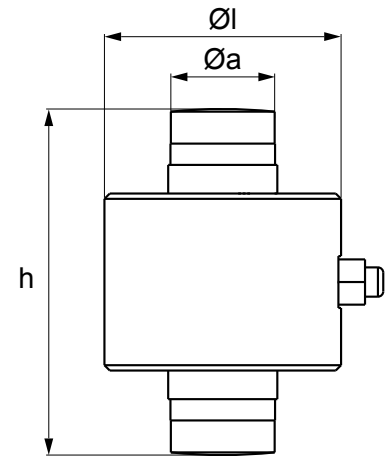

Version codes

Max (kg)	l Ø (mm)	h (mm)	a Ø (mm)	Code
30.000	88,9	130	39	RCA30C4 

ATEX certification

Option	Description	Code
	Optional ATEX version (see www.diniargeo.com for additional details)	CCATEX-1

Technical features

Maximum number of verification intervals	nLC = 4.000
Maximum capacity	30.000 kg
Y value	Vmin = EMax / 10.000
Nominal rated output	2 mV/V ± 10 %
Temperature effect on full scale output	± 0,011 % / °C
Temperature effect on zero	± 0,0014 % / °C
Creep at nominal load over 30 minutes	0,018 % F.S.
Input resistance	815 ± 20 Ω
Output resistance	700 ± 0.35 Ω
Nominal range of excitation voltage	5 - 15 Vdc
Combined error	± 0,013 % F.S.
Insulation resistance	5.000 MΩ / 50 V
Zero balance	< ± 2,5 % F.S.
Compensated temperature range	-10 °C / +40 °C
Operating temperature range	-20 °C / +60 °C
Safe overload	150 % F.S.
Breaking load	300 % F.S.
Shielded cable	

Main options and accessories (for a complete list visit www.diniargeo.com)

Mounting kits	Material	Description	Code
	Zinc-plated steel	Kit of 2 jointed cups for self-alignment and fixing plate	KRCA

RL5426 PLUS | COLUMN

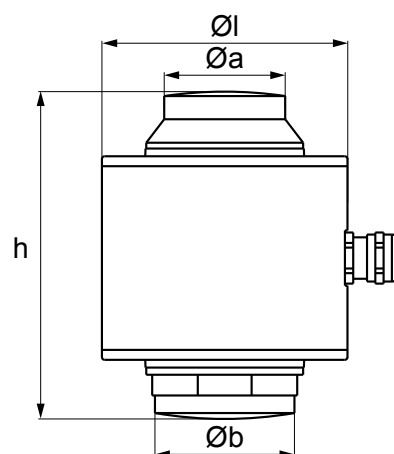



Version codes

Max (kg)	l Ø (mm)	h (mm)	Code
20.000	88,9	118,5	RL5426-20T 
30.000			RL5426-30T 
40.000			RL5426-40T 
50.000			RL5426-50T 

Technical features

Maximum number of verification intervals	nLC = 6.000
Maximum capacity	50.000 kg
Y value	Vmin = Emax / 18.000
Nominal rated output	2 mV/V ± 0,0001 %
Temperature effect on full scale output	0,008 % F.S. / 10°C
Temperature effect on zero	0,02 % F.S. / 10°C
Creep at nominal load over 30 minutes	0,01 % F.S.
Input resistance	800 ± 3 Ω
Output resistance	700 ± 3 Ω
Nominal range of excitation voltage	5 - 15 Vdc
Combined error	0,015 % F.S.
Insulation resistance	> 5.000 MΩ
Zero balance	-
Compensated temperature range	-10 °C / +40 °C
Operating temperature range	-35 °C / +70 °C
Storage temperature range	-40 °C / +80 °C
Safe overload	120 % F.S.
Breaking load	300 % F.S.
Shielded cable	 Ø 6 mm = 20 m

Options & accessories

Mounting kits	Material	Max capacity (kg)	Max lift-off force (kN)	Max side force (kN)	Code
	Stainless steel	-	-	-	173798
	Zinc-plated steel	Up to 40.000 (load cell capacity)	82	67	173801

RL5416 | COLUMN

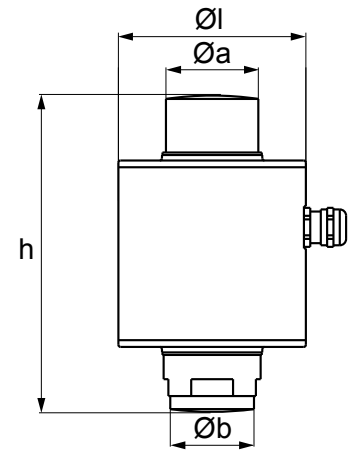
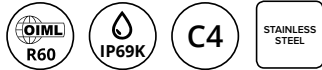

Version codes

Max (kg)	l Ø (mm)	h (mm)	Code
20.000	88,9	150	RL5416-20T 
30.000			RL5416-30T 
40.000			RL5416-40T 
50.000			RL5416-50T 

Technical features

Maximum number of verification intervals	nLC = 4.000
Maximum capacity	50.000 kg
Y value	Vmin = Emax / 14.000
Nominal rated output	2 mV/V ± 0,05 %
Temperature effect on full scale output	0,01 % F.S. / 10°C
Temperature effect on zero	0,02 % F.S. / 10°C
Creep at nominal load over 30 minutes	0,014 % F.S.
Input resistance	800 ± 5 Ω
Output resistance	700 ± 3 Ω
Nominal range of excitation voltage	5 - 15 Vdc
Combined error	0,022 % F.S.
Insulation resistance	> 5.000 MΩ
Zero balance	-
Compensated temperature range	-10 °C / +40 °C
Operating temperature range	-35 °C / +70 °C
Storage temperature range	-40 °C / +80 °C
Safe overload	120 % F.S.
Breaking load	300 % F.S.
Shielded cable	 Ø 6 mm l = 20 m

Options & accessories

Mounting kits	Material	Description	Code
	Stainless steel	Kit of 2 jointed cups for self-alignment of the load cells	173793

RCPT | COLUMN

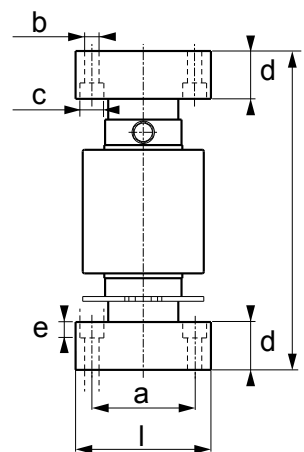

Version codes

Max (kg)	l Ø (mm)	h (mm)	a (mm)	b Ø (mm)	c Ø (mm)	d (mm)	e (mm)	Code	
30.000	85	200	64,5	N°4 x 9	N°4 x 15	30	10	RCPT30C3NC*	
20.000								RCPT20C3-1	
30.000								RCPT30C3	
50.000								RCPT50C3	

*NC = version without cups

ATEX certification

Option	Description	Code
	Optional ATEX version (see www.dinargeo.com for additional details)	CCATEX-1

Technical features

Maximum number of verification intervals	nLC = 3.000
Maximum capacity	50.000 kg
Y value	Vmin = EMax / 10.000
Nominal rated output	2 mV/V ± 0,1 %
Temperature effect on full scale output	0,002 % / °C
Temperature effect on zero	0,002 % / °C
Creep at nominal load over 30 minutes	0,02 % F.S.
Input resistance	700 ± 20 Ω
Output resistance	703 ± 7 Ω
Nominal range of excitation voltage	5 - 15 Vdc
Combined error	-
Insulation resistance	> 5.000 MΩ
Zero balance	± 1 % F.S.
Compensated temperature range	- 10 °C / + 40 °C
Operating temperature range	- 30 °C / +70 °C
Safe overload	150 % F.S.
Breaking load	250 % F.S.
Shielded cable	Ø 5 mm l = 18 m

RCD | COLUMN

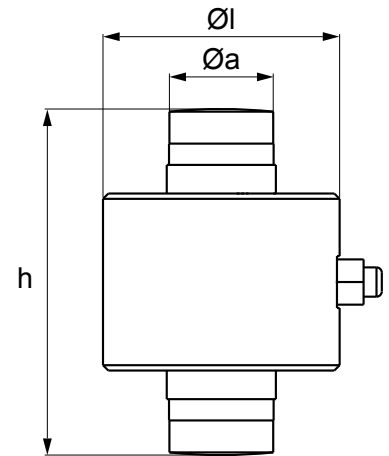

Version codes

Max (kg)	l Ø (mm)	h (mm)	a Ø (mm)	Codice
30.000	88,9	130	39	RCD30C4 
40.000				RCD40C4 
50.000				RCD50C4 

Technical features

Maximum number of verification intervals	nLC = 4.000
Maximum capacity	50.000 kg
Y value	Vmin = EMax / 10.000
Nominal rated output	200.000 digits
Temperature effect on full scale output	0,0012 % / °C
Temperature effect on zero	0,0016 % / °C
Creep at nominal load over 30 minutes	0,021 % F.S.
Nominal range of excitation voltage	5 - 15 Vdc
Combined error	± 0,014 % F.S.
Zero balance	-
Compensated temperature range	-10 °C / +40 °C
Operating temperature range	-20 °C / +60 °C
Safe overload	150 % F.S.
Breaking load	300 % F.S.
Converter rate	Max. 100 conv. / sec.
RS485 Interface communication rate	4.800 / 19.200 bit / sec.
Communication technology	RS485
Communication protocol	Dini Argeo proprietary protocol
Internal resolution	24 bit
Shielded cable	 Ø 9 mm l = 18 m

Main options and accessories (for a complete list visit www.diniargeo.com)

Mounting kits	Material	Description	Code
	Zinc-plated steel	Kit of 2 jointed cups for self-alignment and fixing plate	KRCA

RL5426DC | COLUMN

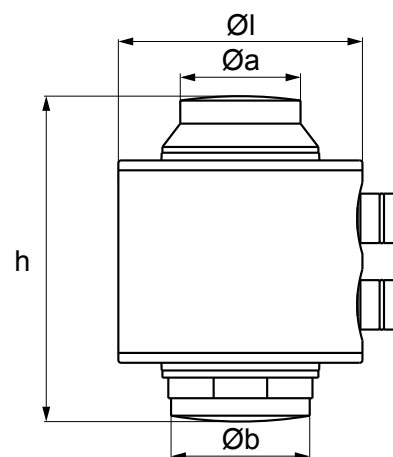

Version codes

Max (kg)	l Ø (mm)	h (mm)	Code	
30.000	88,9	118,5	RL5426DC-30T	
40.000			RL5426DC-40T	

Technical features

Maximum number of verification intervals	nLC = 6.000
Maximum capacity	40.000 kg
Y value	Vmin = Emax / 18.000
Nominal rated output	60.000 digits
Temperature effect on full scale output	0,004 % F.S. / 5°C
Temperature effect on zero	0,01 % F.S. / 5°C
Creep at nominal load over 30 minutes	0,01 % F.S.
Nominal range of excitation voltage	8 - 15 Vdc
Combined error	0,015 % F.S.
Zero balance	± 1 % F.S.
Compensated temperature range	-10 °C / +40 °C
Operating temperature range	-35 °C / +70 °C
Safe overload	150 % F.S.
Breaking load	300 % F.S.
Converter rate	Max. 40 conv. / sec.
RS485 Interface communication rate	Max. 100 kHz
Communication technology	RS485
Communication protocol	Rice Lake proprietary protocol
Internal resolution	24 bit
Shielded cable	Ø 7 mm = 4,5 / 9,5 / 50 m

Options & accessories

Mounting kits	Material	Max capacity (kg)	Max lift-off force (kN)	Max side force (kN)	Code
	Stainless steel	-	-	-	173798
	Zinc-plated steel	Up to 40.000 kg (load cell capacity)	82	67	173801

RL5416DC | COLUMN

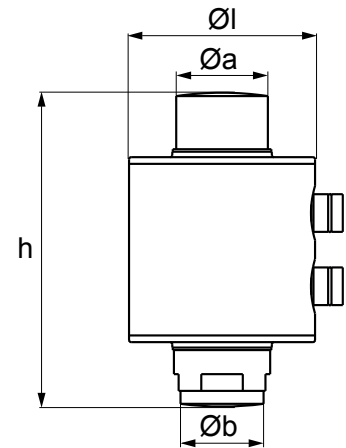

Version codes

Max (kg)	l Ø (mm)	h (mm)	Code
30.000	88,9	150	RL5416DC-30T 
40.000			RL5416DC-40T 

Technical features

Maximum number of verification intervals	nLC = 4.000
Maximum capacity	40.000 kg
Y value	Vmin = Emax / 18.000
Nominal rated output	40.000 punti
Temperature effect on full scale output	0,01 % F.S. / 10°C
Temperature effect on zero	0,02 % F.S. / 10°C
Creep at nominal load over 30 minutes	0,014 % F.S.
Nominal range of excitation voltage	8 - 15 Vdc
Combined error	0,022 % F.S.
Zero balance	-
Compensated temperature range	-10 °C / +40 °C
Operating temperature range	-35 °C / +70 °C
Safe overload	120 % F.S.
Breaking load	300 % F.S.
Converter rate	Max. 40 conv. / sec.
RS485 Interface communication rate	Max. 100 kHz
Communication technology	RS485
Communication protocol	Rice Lake proprietary protocol
Internal resolution	24 bit
Shielded cable	 Ø 7 mm l = 4,5 / 9,5 / 50 m

Options & accessories

Mounting kits	Material	Description	Code
	Stainless steel	Kit of 2 jointed cups for self-alignment of the load cells	173793

RCPTD | COLUMN

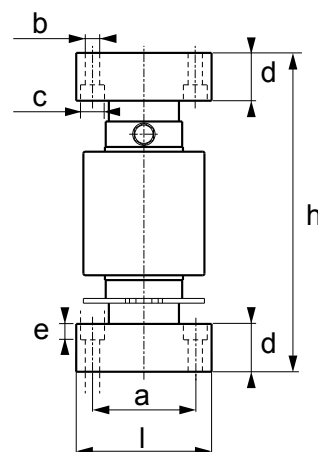

Version codes

Max (kg)	l Ø (mm)	h (mm)	a (mm)	b Ø (mm)	c Ø (mm)	d (mm)	e (mm)	Code
30.000	85	200	64,5	N°4 x 9	N°4 x 15	30	10	RCPTD30C4-2 

Technical features

Maximum number of verification intervals	nLC = 4.000
Maximum capacity	30.000 kg
Y value	-
Nominal rated output	60.000 digits
Temperature effect on full scale output	± 0,02 % F.S.
Temperature effect on zero	-
Creep at nominal load over 30 minutes	± 0,03 % F.S.
Nominal range of excitation voltage	10 - 18 Vdc
Combined error	± 0,01 % F.S.
Zero balance	± 0,02 % F.S. / 10 °C
Compensated temperature range	-10 °C / +40° C
Operating temperature range	-10 °C / +70° C
Safe overload	150 % F.S.
Converter rate	Max. 20 conv. / sec.
RS485 Interface communication rate	Max. 100 kHz
Communication technology	RS485
Communication protocol	Dini Argeo proprietary protocol
Internal resolution	24 bit
Shielded cable	 Ø 5 mm l = 18 m

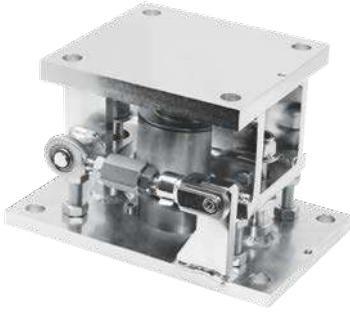
173801 | MOUNTING KIT

Mounting kits for RL5426 and RL5426DC series Column load cells up to 40.000 kg. Suitable for weighing large capacity silos, tanks and hoppers.

ZINC
PLATED
STEEL

Version codes

Mounting kits	Material	Weight (kg)	Max capacity (kg)	Max lift-off force (kN)	Max side force (kN)	Code	
	Zinc-plated steel	20	Up to 40.000 kg (load cell capacity)	82	67	173801	

Technical features

Construction in zinc-plated steel
Anti-tipping system
Locking/bypass system for easy transport and maintenance
Overload protection nuts
Great resistance to lateral forces
Locking nuts to maintain the raised position simplify the installation and the removal of the load cell

Main options and accessories *(for a complete list visit www.diniargeo.com)*

Option	Description	Code	
	Grounding cable for weighing kit. 16 mm ² section cable, 20 mm eyelets.	GNDC20-1	

This kit is designed to allow the correct functioning of the cells and the requested weighing accuracy, within the limits described into the technical manual.

Technical drawing (mm)

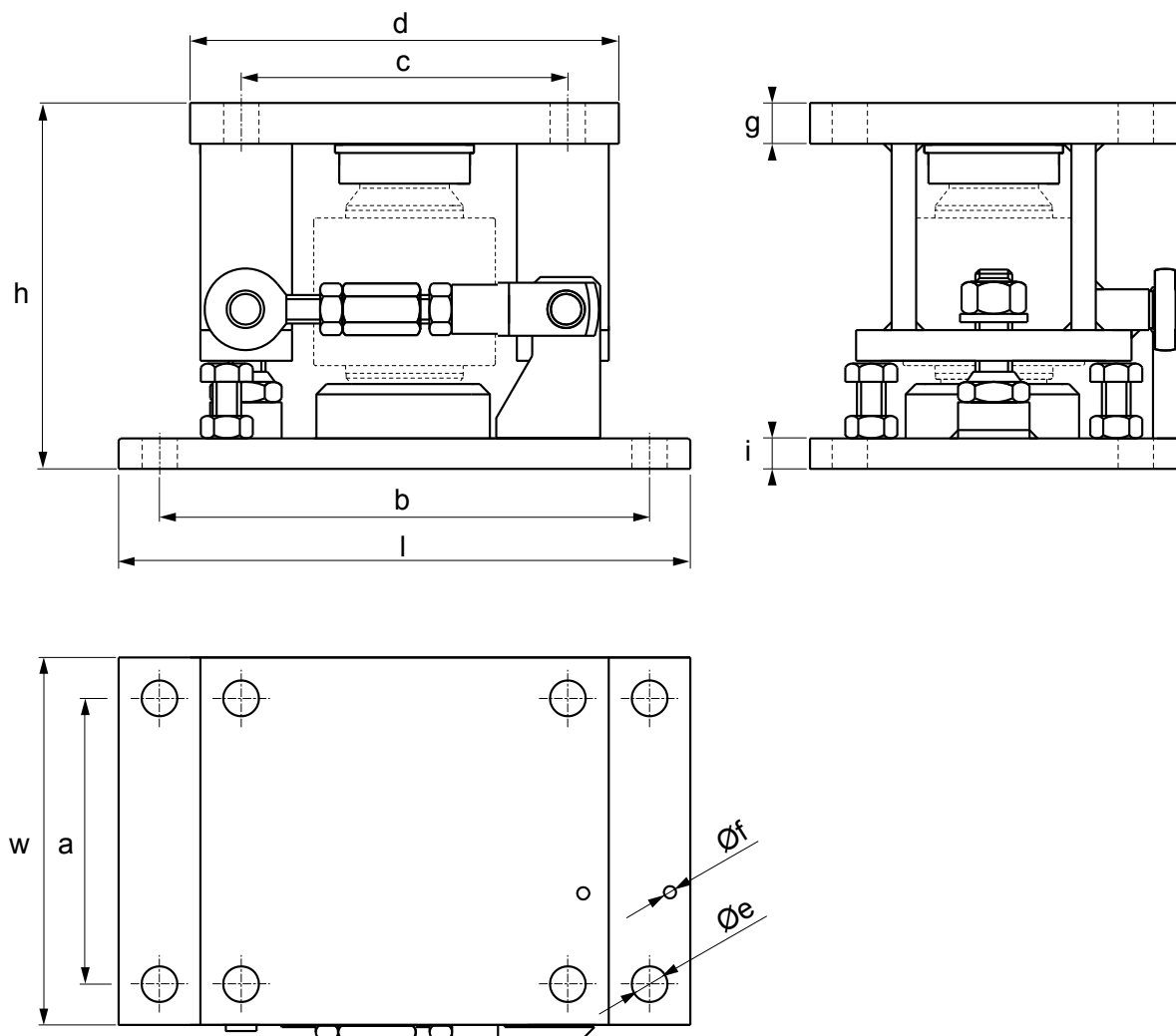

Max (kg)	l (mm)	w (mm)	h (mm)	a (mm)	b (mm)	c (mm)	d (mm)	e \varnothing (mm)	f \varnothing (mm)	g (mm)	i (mm)	Code
40.000	280	180	180	140	240	160	160	17,5	N°2 x M8	200	150	173801

LOAD PINS



Load Pins are a key component in the construction of weighing or safety control systems. Designed and manufactured specifically for each integrated solution, they are suitable for a wide range of applications and areas: industrial, agricultural, logistics, automotive, civil, construction.

Particularly suitable for moving applications such as cranes, overhead cranes, bulldozers, hoists and robotic booms. Dini Argeo designs and manufactures customized Load Pins to meet customer's needs and to suit any weighing application. Contact our sales office for further information.



The strength of the Load Pins is to be custom made to replace existing pins, introducing weight reading at strategic points where other load cells could not be installed.



ACCESSORIES LOAD CELLS

“

Dini Argeo offers a complete range of junction boxes and accessories to connect load cells to weighing electronics.

”

ABS | JUNCTION BOXES

















Option	Dimensions (mm)	Equalisation	Fairleads	Material	Surge Arresters	IP Rate	Ex	Code	
	120 x 80 x 55	-	4+1 (PG9)	ABS	-	IP67	-	JB4	
	120 x 80 x 55	-	4+1 (PG9)	ABS	-	IP67	•	JB4A 	
	120 x 80 x 55	•	4+1 (PG9)	ABS	-	IP67	-	JB4Q	
	120 x 80 x 55	•	4+1 (PG9)	ABS	-	IP67	•	JB4QA 	
	120 x 80 x 55	•	4+1 (PG9)	ABS	•	IP67	-	JB4PLUS	
	220 x 120 x 90	•	8+1 (PG11)	POLYESTER	•	IP66	-	JB8Q-1	
	220 x 120 x 90	•	10+1 (PG9)	POLYESTER	•	IP66	-	JB10Q	
	220 x 120 x 90	•	10+1 (PG9)	POLYESTER	•	IP66	-	JB10QD-1	

Main options and accessories (for a complete list visit www.diniargeo.com)

Option	Description	Code	
	Anti-condensation, insulating and sealing gel. Useful to protect the electronic circuits of the weighing system, even under prolonged immersion.	GELBOX	

- As standard

STAINLESS STEEL | JUNCTION BOXES

Option	Dimensions (mm)	Equalisation	Fairleads	Material	Surge Arresters	IP Rate	Ex	Code	
		-	1+1 (PG9)	Stainless steel	-	IP68	-	JB1I	
	190 x 130 x 45	-	1+1 (PG9)	Stainless steel	-	IP66	•	JB1AI 	
	190 x 130 x 45	•	2+1 (PG9)	Stainless steel	-	IP66	•	JB2QAI 	
	190 x 130 x 45	•	3+1 (PG9)	Stainless steel	-	IP66	•	JB3QAI 	
	190 x 130 x 45	-	4+1 (PG9)	Stainless steel	-	IP66	•	JB4AI 	
	155 x 158 x 45	•	4+1 (PG9)	Stainless steel	-	IP65	-	JB4QI	
	190 x 130 x 45	•	4+1 (PG9)	Stainless steel	-	IP66	•	JB4QAI 	
	221 x 105 x 39	•	4+1 (PG9)	Stainless steel	•	IP68 IP69K	-	JB4QIP69K	
	190 x 132 x 50	•	6+1 (PG9)	Stainless steel	-	IP65	-	JB6QI	
	343 x 132 x 66	•	10+1 (PG11)	Stainless steel	•	IP68 IP69K	•	JB10QIP69K-1 	

Main options and accessories (for a complete list visit www.dinargeo.com)

Option	Description	Code	
	Anti-condensation, insulating and sealing gel. Useful to protect the electronic circuits of the weighing system, even under prolonged immersion.	GELBOX	

- As standard

ZBA1S | ZENER BARRIER







ZBA1S Zener barrier is the perfect solution for the connection between a weighing terminal and a weight receiver system in the ATEX zone. ZBA1S integrates three barriers in one, protecting the excitation, signal and sense line.

This feature makes the installation easier, especially in small spaces.

Available also as ATEX ABS housing kit.

Version codes

Option	Description	Code	
	Intrinsic protection three channel Zener barrier. Specific for connection to load cells, for mounting on DIN rail in a safe area, or in a flame-proof case.	ZBA1S	
	Shielded 6 x 0,25 mm ² cable (suitable for Ex zones). €/m	LCCB	
		LCCBA	
	Shielded, blue, 6 x 0,22 mm ² cable, for EX i (2GD) applications. €/m	EXCB6	

ATEX certification

Option	Description	Code	
	ATEX declaration for the whole system with Dini Argeo Zener barriers. Ex II 2G IIC T6 Gb X e Ex II 2D IIIC T125°C Db X system, with label of the whole system, for weight indicator connected to Dini Argeo zener barriers, connected to a mechanical structure with ATEX load cells (each cell must be certified with CCATEX option). Provided with descriptive document of the assembly and ATEX EU declaration of conformity of the assembly (EN and IT).	DCATEXMB4	

Technical features

Three channels passive Zener barrier for excitation, signal and sense line.
Ex marking: ATEX II (1)G, II (1)D, I (M1) IECEX [circuit(s) in zone 0/1/2]
Protection: [Ex ia Ga] IIC, [Ex ia Da] IIIC, [Ex ia Ma] I (-20 °C ≤ Tamb ≤ +60 °C)
Equipped with 3 channels for the protection of the the excitation line (CN3/CN6), signal line (CN1/CN4) and the sense line (CN2/CN5), for improved signal stability.
“SLIM” type case, iper-compact, for DIN rail installation.
Operating temperature: -20 °C ÷ +60 °C.
Storage temperature: -25 °C ÷ +70 °C
Rating: 14 Vrms differential and 8 Vrms through earth for CN3 connector, 20 Vrms for the CN1 & CN2
Maximum Security Voltage (Um): 250 Vrms
Maximum Security Current (current interruption capability): 1500 A
Protection rating: IP20

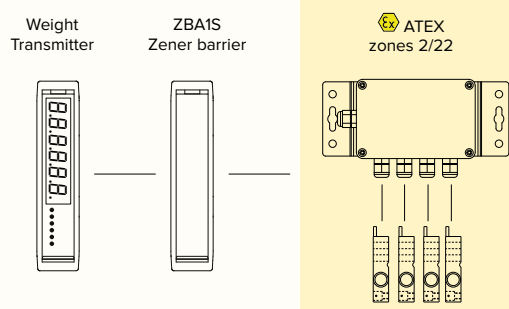



LCCB | CABLE



Shielded cable for connection of weight indicators to load cells or junction boxes.



Version codes

Option	Description	Code	
	Shielded 6 x 0,25 mm ² cable (suitable for Ex zones). €/m	LCCB	
	Protection sheathing for shielded cable. €/m	PRCB	

Technical features

Type	6 pins x 0,25 mm ² .
Conductor	Flexible bare copper class 5.
Insulation	PVC compound type R2.
Shield	Tinned copper braid shield; coverage 80%.
Sheath	PVC inner sheath. Gray PVC outer sheath, 5.8 mm diameter.
Laying	Fixed. Maximum drawing strength 50 N/mm ² of total copper section. Minimum bending radius: outer diameter of cable times 6.
Temperature range	-40 / +80 °C

LCCBA | CABLE



Armoured cable for connection of weight indicators to load cells or junction boxes.



Version codes

Option	Description	Code	
	Armoured 6 x 0,25 mm ² cable (suitable for Ex zones). €/m	LCCBA	

Technical features

Type	6 pins x 0,25 mm ² .
Conductor	Flexible bare copper, class 14 x 0,15 mm (0,25 mm ² - AWG24).
Insulation	Composed of PVC (Y), hardness 94 Sha, nominal diameter 1.25 ± 0.1 mm.
Shield	Iron-zinc alloy armour, coverage > 85%.
Sheath	PVC inner sheath, 5 mm diameter. Transparent PVC outer sheath, 8 mm diameter.
Laying	Fixed. Minimum bending radius: outer diameter of cable times 7.
Temperature range	-15 / +70 °C.

OFF-CENTER

BENDING
BEAMSHEAR
BEAMDOUBLE
SHEAR BEAM

TENSION

COMPRESSION

COLUMN

LOAD PINS



OTHER

LCCBM | CABLE



Shielded cable for connection of weight indicators to load cells or junction boxes.

Version codes

Option	Description	Code	
	Shielded 4 x 0,34 mm ² cable for moving applications. €/m.	LCCBM	
	Protection sheathing for shielded cable. €/m	PRCB	

Technical features

Type	4 pins x 0,34 mm ² .
Conductor	Extra-flexible copper class 6.
Insulation	Polyolefin.
Shield	Tinned copper braid shield; coverage ≥ 85%.
Sheath	Green, abrasion-resistant Polyurethane.
Laying	Dynamic. Minimum bending radius: outer diameter of cable times 6.

EXCB6 | CABLE

Shielded cable for connection of weight indicators to load cells or junction boxes.



Version codes

Option	Description	Code	
	Shielded, blue, 6 x 0,22 mm ² cable, for EX i (2GD) applications. €/m	EXCB6	

Technical features

Type	6 pins x 0,22 mm ² .
Conductor	Stranded tinned copper class 6.
Insulation	PVC + 105°.
Shield	Tinned copper braid shield; coverage 80%.
Sheath	PVC inner sheath. Blue Polyurethane outer sheath, 5.8 mm diameter.
Laying	Fixed. Minimum bending radius: outer diameter of cable times 7.
Temperature range	-40 / +80 °C

HIGH SPEED PROCESS & AUTOMATION WEIGHT TRANSMITTERS

“

These weight transmitters are designed for use in applications where a very high sampling rate is required in order to weigh with extreme precision in fractions of a second.

Ideal for belt weighing, micro-dosing and dosing, in-line filling and process control applications.

”

HIGH SPEED PROCESS & AUTOMATION WEIGHT TRANSMITTERS

Comparative table

		DGT1SX	DGT1SX CHECK	DGT4X	DGT4X DIGITAL	DGT4XBD
Number of scales / channels		1	1	Up to 4	Up to 1	Up to 4
Conversion rate		Up to 4.800 Hz	Up to 4.800 Hz	Up to 2.600 Hz	Up to 1.600 Hz	Up to 2.600 Hz
Web server		•	•	•	•	•
Integrated fieldbus		•	•	•	•	•
Modbus RTU		•	•	•	•	•
RS485		•	•	•	•	•
RS232		•	•	•	•	•
USB		•	•	•	•	•
Digital I/O		•	•	•	•	•
Analog Output		•	•	•	•	•
Case		ABS	ABS	ABS	ABS	ABS
Electric approvals	UL Listed	Upon request	Upon request	Upon request	Upon request	Upon request
Metrological approvals	OIML R61 MID	•	•	•	•	•
	OIML R51	•	•	•	•	•
	OIML R76	•	•	•	•	•
	EU Type Examination certificate	•	•	•	•	•

DGT1SX | 1 CHANNEL

WITH INTEGRATED FIELDBUS & WEB SERVER

Highlights:

- high-speed sampling
- load cell status diagnostics
- USB port for quick programming

LOAD CELL
FAILURE ALARM4.800 Hz
SUPER FASTOIML
APPROVEDUSB
PORTWEB
SERVER

Main features

Technical features				
Number of scales / channels		1		
Calibration		Electronic (Theoretical)	Real calibration with sample weights	Via Web server
Conversion rate		Up to 4.800 Hz		
Maximum display digits		0..800.000		
Maximum load cell number		Up to 16 x 350 Ω		
Minimum sensitivity	High resolution	0,01 μV/d		
	Legal for trade	0,3 μV/e		
Legal for trade number of intervals		Up to 10.000e or multirange 2 x 3.000e		
Load cell excitation voltage		5 V		
Communication ports		See version table		
Communication protocols		Modbus RTU, ASCII or fieldbus		
Communication rate		Via serial port		Via Fieldbus
		Up to 1.600 Hz		Up to 120 Hz
Configuration PC utility		DiniTools, XSpeedTool		
Display		Red LED 8 mm, 6 digits		
Keyboard		Mechanical, 5 keys		
Case		ABS (UL compliant)		
Power supply		12÷24 Vdc, 5 W		
Operating temperature range		Internal Use	OIML approved	Humidity
		-20 °C / +60 °C	-10 °C / +40 °C	85 %

Approvals	Type	Description
UL Listed	Electric	Upon request
2014/30/EU EMC	Electric	EN 61000-6-2 : 2005
		EN 61000-6-4 : 2007+A1 : 2011
		EN 61326-1 : 2013 EN 61326-1 : 2013
		EN 55011 : 2009+A1 : 2010 EN 55011 : 2009+A1 : 2010
2014/35/EU LVD	Electric	EN 61010-1 : 2010
2011/65/EU (RoHS)	Electric	EN 50581 : 2012
OIML R61 - MID	Metrological	AWI - Automatic filling machine
OIML R51 - MID	Metrological	AWI - Checkweighers
OIML R76	Metrological	NAWI - Weight transmitter
EU Type Examination Certificate (2014/31/EU)	Metrological	NAWI - Weight transmitter

Analog output	
Settings	0÷5 Vdc, 0÷10 Vdc, 0÷20 mA, 4÷20 mA
Resolution	16 bit
Communication rate	0,1 s
Opto-isolated as standard	Yes

Digital inputs / outputs	V	I
2 Digital inputs	5÷48 Vdc	-
2 Digital outputs	48 Vdc	500 mA
Opto-isolated as standard	Yes	

Version codes

Fieldbus	Analog output	Modbus RTU	RS485	2 IN / 4 OUT	USB	Web server	Code	
		•	•	•	•		DGT1SX	
		•	•	•	•		DGT1SX-AN	
PROFINET	•			•	•	•	DGT1SX-PRONET	
EtherNet/IP	○			•	•	•	DGT1SX-ETHIP	
Modbus TCP/IP	○			•	•	•	DGT1SX-MODTCP	
EtherCAT	○			•	•		DGT1SX-ETHCAT	
Profibus	○			•	•		DGT1SX-PB	
CANopen	○			•	•		DGT1SX-CANOP	
DeviceNet	○			•	•		DGT1SX-DEVNET	

○ Special version, ask for estimate.

Main options and accessories *(for a complete list visit www.dinargeo.com)*

	Description	Code	
POWER SUPPLY	 12 Vdc power supply unit for DIN rail mounting. 110/240 Vac input. CE and UL certified. Not compatible with BOX2121S.	MDR2012	

	Description	Code	
PC SOFTWARES	 "XSPEED" PC software with oscilloscope function for system diagnostics and weighing filter optimization.	XSPEED	

Technical drawing (mm)

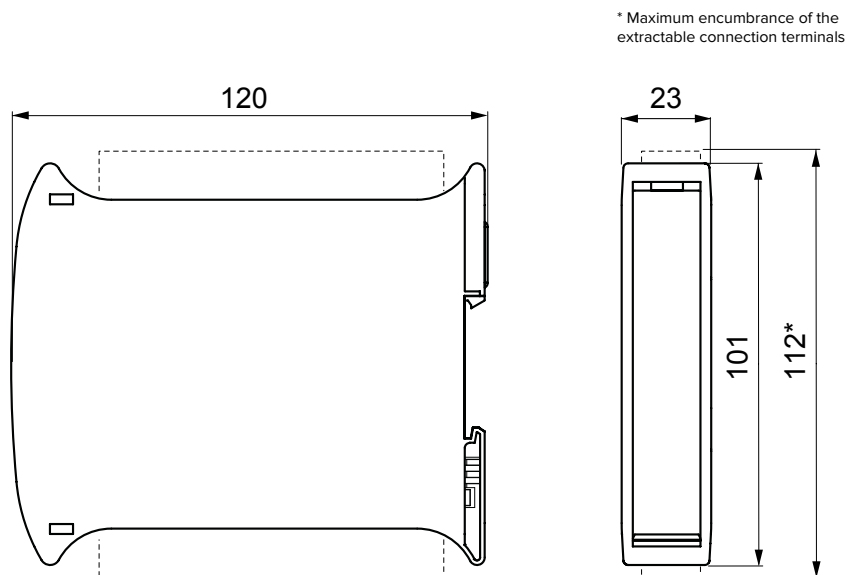

DGT1SX CHECK | 1 CHANNEL

WITH INTEGRATED FIELDBUS & WEB SERVER

Highlights:

- high-speed sampling
- load cell status diagnostics
- automatic package detection
- USB port for quick programming
- memory of the last 10 weight readings

LOAD CELL
FAILURE ALARM4.800 Hz
SUPER FASTOIML
APPROVEDUSB
PORTWEB
SERVER

Main features

Technical features				
Number of scales / channels		1		
Calibration		Electronic (Theoretical)	Real calibration with sample weights	Via Web server
Conversion rate		Up to 4.800 Hz		
Maximum display digits		0..800.000		
Maximum load cell number		Up to 16 x 350 Ω		
Minimum sensitivity	High resolution	0,01 μV/d		
	Legal for trade	0,3 μV/e		
Legal for trade number of intervals		Up to 10.000e or multirange 3.000 + 3.000e		
Load cell excitation voltage		5 V		
Communication ports		See version table		
Communication protocols		Modbus RTU, ASCII or fieldbus		
Communication rate		Via serial port	Via Fieldbus	Via Modbus RTU
		Up to 1.600 Hz	Up to 120 Hz	Up to 100 Hz
Configuration PC utility		XSpeedTool		
Display		Red LED 8 mm, 6 digits		
Keyboard		Mechanical, 5 keys		
Case		ABS, for DIN rail (120 x 23 x 112 mm)		
Power supply		12÷24 Vdc		
Operating temperature range		Internal Use	OIML approved	Humidity
		-20 °C / +60 °C	-10 °C / +40 °C	85 % without condensation

Approvals	Type	Description
UL Listed	Electric	Upon request
2014/30/EU EMC	Electric	EN 61000-6-2 : 2005 EN 61000-6-4 : 2007+A1 : 2011 EN 61326-1 : 2013 EN 61326-1 : 2013 EN 55011 : 2009+A1 : 2010 EN 55011 : 2009+A1 : 2010
2014/35/EU LVD	Electric	EN 61010-1 : 2010
2011/65/EU (RoHS)	Electric	EN 50581 : 2012
OIML R61 - MID	Metrological	AWI - Automatic filling machine
OIML R51 - MID	Metrological	AWI - Checkweighers
OIML R76	Metrological	NAWI - Weight transmitter
EU Type Examination Certificate (2014/31/EU)	Metrological	NAWI - Weight transmitter



Analog output	
Settings	0÷5 Vdc, 0÷10 Vdc, 0÷20 mA, 4÷20 mA
Resolution	16 bit
Communication rate	0,1 s
Opto-isolated as standard	Yes

Digital inputs / outputs	V	I
2 Digital inputs	5÷48 Vdc	-
4 Digital outputs	48 Vdc	500 mA
Opto-isolated as standard	Yes	

Version codes

Fieldbus	Analog output	Modbus RTU	RS485	2 IN / 4 OUT	USB	Web server	Code	
		•	•	•	•		DGT1SXCK	
PROFINET	○			•	•	•	DGT1SXCK-PRONET	
EtherNet/IP	○			•	•	•	DGT1SXCK-ETHIP	
Modbus TCP/IP	○			•	•	•	DGT1SXCK-MODTCP	

Main options and accessories (for a complete list visit www.diniargeo.com)

	Description	Code	
POWER SUPPLY	 12 Vdc power supply unit for DIN rail mounting. 110/240 Vac input. CE and UL certified. Not compatible with BOX2121S.	MDR2012	
PC SOFTWARES	 "XSPEED" PC software with oscilloscope function for system diagnostics and weighing filter optimization.	XSPEED	

Technical drawing (mm)

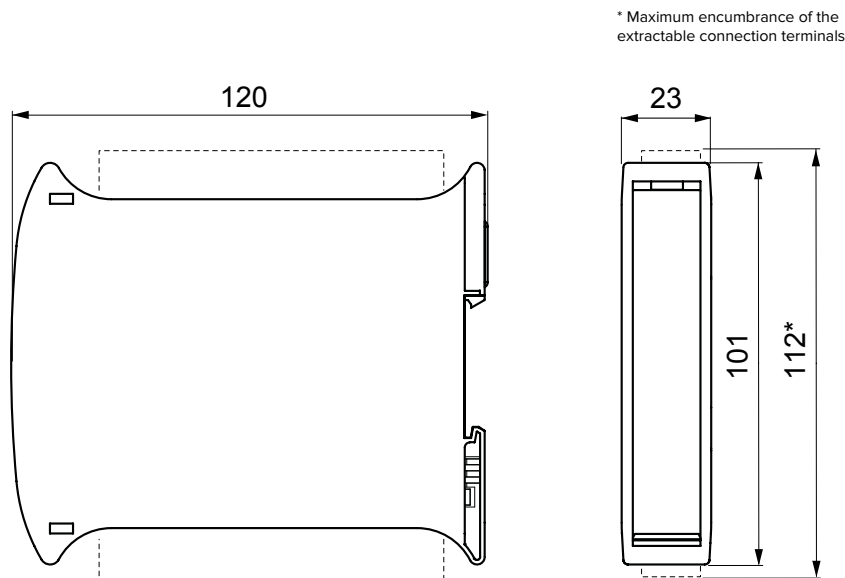

DGT4X | 4 CHANNELS

WITH INTEGRATED FIELDBUS & WEB SERVER

Highlights:

- smart junction box mode
- load unbalance warning
- optional digital load cell management
- faulty load cell exclusion
- USB port for quick programming

2.600 Hz
SUPER FASTOIML
APPROVEDUSB
PORTWEB
SERVERJBOX
MODEUP TO 4
SCALES



Main features

Technical features					
Number of scales / channels		Up to 4			
Calibration		Electronic (Theoretical)	Real calibration with sample weights	Via Web server Via XSpeedTool	
Conversion rate		Single-channel (1 scale)		Multi-channel (up to 4 scales)	
		Up to 2.600 Hz		Up to 9.000 Hz	
Maximum display digits		0..800.000			
Maximum load cell number		Up to 16 x 350 Ω			
Minimum sensitivity		High resolution			
		Legal for trade			
		0,01 μV/d			
		0,3 μV/e			
Legal for trade number of intervals		Up to 10.000e or multirange 2 x 3.000e			
Load cell excitation voltage		5 V			
Communication ports		See version table			
Communication protocols		Modbus RTU, ASCII or fieldbus			
Web server		See version table			
Communication rate		Via serial port		Via Fieldbus	
		Up to 1.300 Hz		Up to 120 Hz	
Configuration PC utility		DiniTools, XSpeedTool			
Display		Red LED 14,2 mm, 7-segment, 6 digits			
Keyboard		Mechanical, 5 keys			
Case		ABS			
Power supply		12÷24 Vdc, 5 W			
Operating temperature range		Internal Use	OIML approved	Humidity	
		-20 °C / +60 °C	-10 °C / +40 °C	85 %	
Approvals		Type	Description		
UL Listed		Electric	Upon request		
2014/30/EU EMC		Electric	EN 61000-6-2 : 2005 EN 61000-6-4 : 2007+A1 : 2011 EN 61326-1 : 2013 EN 61326-1 : 2013 EN 55011 : 2009+A1 : 2010 EN 55011 : 2009+A1 : 2010		
2014/35/EU LVD		Electric	EN 61010-1 : 2010		
2011/65/EU (RoHS)		Electric	EN 50581 : 2012		
OIML R61 - MID		Metrological	AWI - Automatic filling machine		
OIML R51 - MID		Metrological	AWI - Checkweighers		
OIML R76		Metrological	NAWI - Weight transmitter		
EU Type Examination Certificate (2014/31/EU)		Metrological	NAWI - Weight transmitter		
Analog output		Digital inputs / outputs		V	I
Settings	0÷5 Vdc, 0÷10 Vdc, 0÷20 mA, 4÷20 mA	2 Digital inputs		12÷24 Vdc	5÷20 mA
Resolution	16 bit	2 Digital outputs		48 Vac 60 Vdc	500 mA
Communication rate	0,1 s	Opto-isolated as standard		Yes	
Opto-isolated as standard	Yes				

Version codes

Fieldbus	Analog output	Modbus RTU	RS485	RS232	2 IN / 2 OUT	USB	Web server	Code	
		•	•	•	•	•		DGT4X	
	•	•	•	•	•	•		DGT4XAN	
PROFINET			•		•	•	•	DGT4XPRONET	
EtherNet/IP			•		•	•	•	DGT4XETHIP	
Modbus TCP/IP			•		•	•	•	DGT4XMODTCP	
EtherCAT			•		•	•		DGT4XETHCAT	
Profibus			•		•	•		DGT4XPB	
CANopen			•		•	•		DGT4XCANOP	
DeviceNet			•		•	•		DGT4XDEVNET	

Main options and accessories (for a complete list visit www.diniargeo.com)

	Description	Code	
POWER SUPPLY	 12 Vdc power supply unit for DIN rail mounting. 110/240 Vac input. CE and UL certified. Not compatible with BOX2121S.	MDR2012	
PC SOFTWARES	 "XSPEED" PC software with oscilloscope function for system diagnostics and weighing filter optimization.	XSPEED	

Technical drawing (mm)

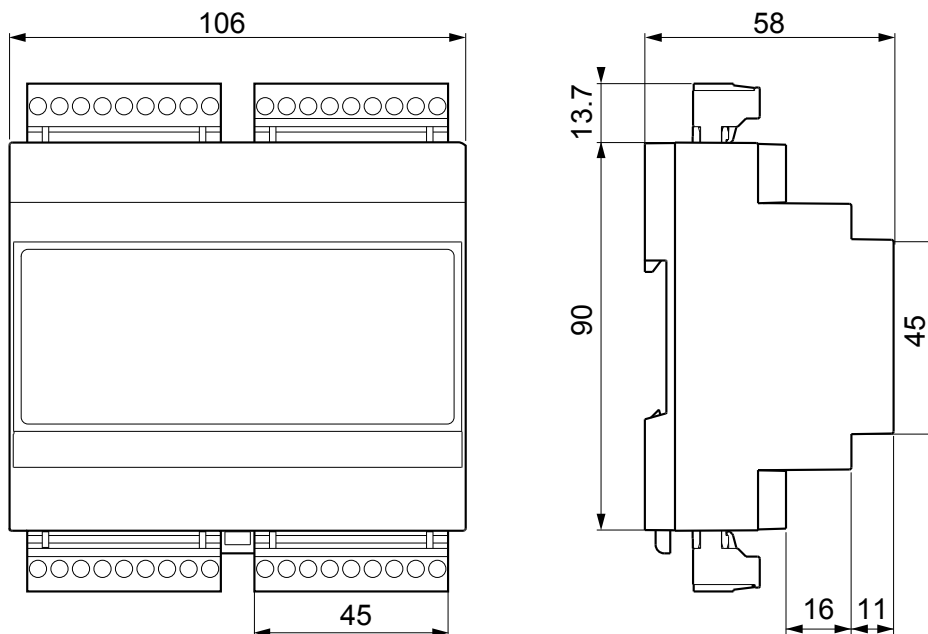

DGT4X DIGITAL | 4 CHANNELS

WITH INTEGRATED FIELDBUS & WEB SERVER

Highlights:

- load cell addressing
- quick replacement of load cells
- load cell exclusion (silo weighing)
- load balance monitoring
- digital equalization
- calibration
- all main scale functions (zero, tare, automatic zeroing, etc.).



2.600 Hz
SUPER FAST



OIML
APPROVED



USB
PORT



WEB
SERVER



JBOX
MODE



UP TO 4
SCALES



Main features

Technical features	
Number of scales / channels	Up to 4
Calibration	Electronic (Theoretical) Real calibration with sample weights Via Web server From keyboard From PC with Dinitools
Conversion rate	Single-channel (1 scale) Multi-channel (up to 4 scales) Up to 2.600 Hz Up to 100Hz with 4 channels
Maximum display digits	0..800.000
Maximum load cell number	Up to 16 digital load cells
Minimum sensitivity	High resolution 0,01 µV/d Legal for trade 0,3 µV/e
Legal for trade number of intervals	Up to 10.000e or multirange 3.000 + 3.000e
Load cell excitation voltage	Digital load cells require an optional dedicated power supply unit
Communication ports	See version table
Communication protocols	Modbus RTU, ASCII or fieldbus
Web server	See version table
Communication rate	Via serial port Via Fieldbus Up to 1.300 Hz Up to 120 Hz
Configuration PC utility	DiniTools
Display	Red LED 14,2 mm, 6 characters
Keyboard	Mechanical, 5 keys
Case	ABS, for DIN rail (106 x 56 x 118 mm)
Power supply	12÷24 Vdc
Operating temperature range	Internal Use OIML approved Humidity -20 °C / +60 °C -10 °C / +40 °C 85 % without condensation

Approvals	Type	Description
UL Listed	Electric	Upon request
2014/30/EU EMC	Electric	EN 61000-6-2 : 2005 EN 61000-6-4 : 2007+A1 : 2011 EN 61326-1 : 2013 EN 61326-1 : 2013 EN 55011 : 2009+A1 : 2010 EN 55011 : 2009+A1 : 2010
2014/35/EU LVD	Electric	EN 61010-1 : 2010
2011/65/EU (RoHS)	Electric	EN 50581 : 2012
Australian approval	Metrological	NAWI - Weight transmitter
OIML R76	Metrological	NAWI - Weight transmitter
EU Type Examination Certificate (2014/31/EU)	Metrological	NAWI - Weight transmitter

Analog output	
Settings	0÷5 Vdc, 0÷10 Vdc, 0÷20 mA, 4÷20 mA
Resolution	16 bit
Communication rate	0,1 s
Opto-isolated as standard	Yes

Digital inputs / outputs	V	I
2 Digital inputs	12÷24 Vdc	5÷20 mA
2 Digital outputs	48 Vac 60 Vdc	500 mA
Opto-isolated as standard	Yes	

Version codes

Fieldbus	Analog output	Modbus RTU	RS485	RS232	2 IN / 2 OUT	USB	Web server	Code	
		•	•	•	•	•		DGT4XDL	
	•	•	•	•	•	•		DGT4XDLAN	
PROFINET			•		•	•	•	DGT4XDLPRONET	

Main options and accessories (for a complete list visit www.diniargeo.com)

	Description	Code	
POWER SUPPLY	 12 Vdc power supply unit for DIN rail mounting. 110/240 Vac input. CE and UL certified. Not compatible with BOX2121S.	MDR2012	

Technical drawing (mm)

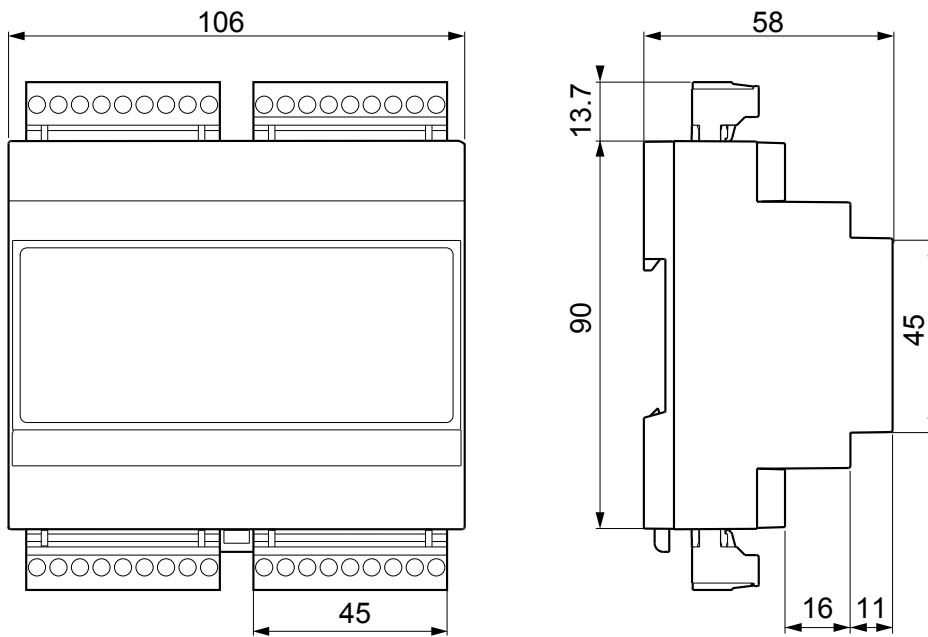

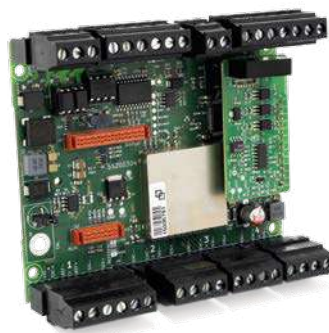
DGT4XBD | 4 CHANNELS2.600 Hz
SUPER FASTJBOX
MODEUP TO 4
SCALES**Main features**



Technical features			
Number of scales / channels	Up to 4		
Calibration	Electronic (Theoretical)	Real calibration with sample weights	Via XSpeedTool
Conversion rate	Up to 2.600 Hz		
Maximum load cell number	Up to 16 x 350 Ω		
Minimum sensitivity	0,01 μV/d		
Load cell excitation voltage	5 V		
Communication protocols	Modbus RTU, ASCII		
Communication rate	Up to 60 Hz		
Configuration PC utility	XSpeedTool		
Power supply	4,5÷24 Vdc, 5 W		
Operating temperature range	Internal Use	Humidity	
	-20 °C / +60 °C	85 %	

Approvals	Type	Description
2014/30/EU EMC	Electric	EN 61000-6-2 : 2005
		EN 61000-6-4 : 2007+A1 : 2011
		EN 61326-1 : 2013 EN 61326-1 : 2013
		EN 55011 : 2009+A1 : 2010 EN 55011 : 2009+A1 : 2010
2014/35/EU LVD	Electric	EN 61010-1 : 2010
2011/65/EU (RoHS)	Electric	EN 50581 : 2012

Version codes

Fieldbus	Analog output	Modbus RTU	RS485	RS232	2 IN / 2 OUT	USB	Web server	Code	
		•	•	•	•	•		DGT4XBD	
	•	•	•	•	•	•		DGT4XANBD	
PROFINET			•		•	•	•	DGT4XPRONETBD	
EtherNet/IP			•		•	•	•	DGT4XETHIPBD	
Modbus TCP/IP			•		•	•	•	DGT4XMODTCPBD	
EtherCAT			•		•	•		DGT4XETHCATBD	

Main options and accessories *(for a complete list visit www.dinargeo.com)*

	Description	Code	
POWER SUPPLY	 12 Vdc power supply unit for DIN rail mounting. 110/240 Vac input. CE and UL certified. Not compatible with BOX2121S.	MDR2012	
PC SOFTWARES	 "XSPEED" PC software with oscilloscope function for system diagnostics and weighing filter optimization.	XSPEED	

Technical drawing (mm)

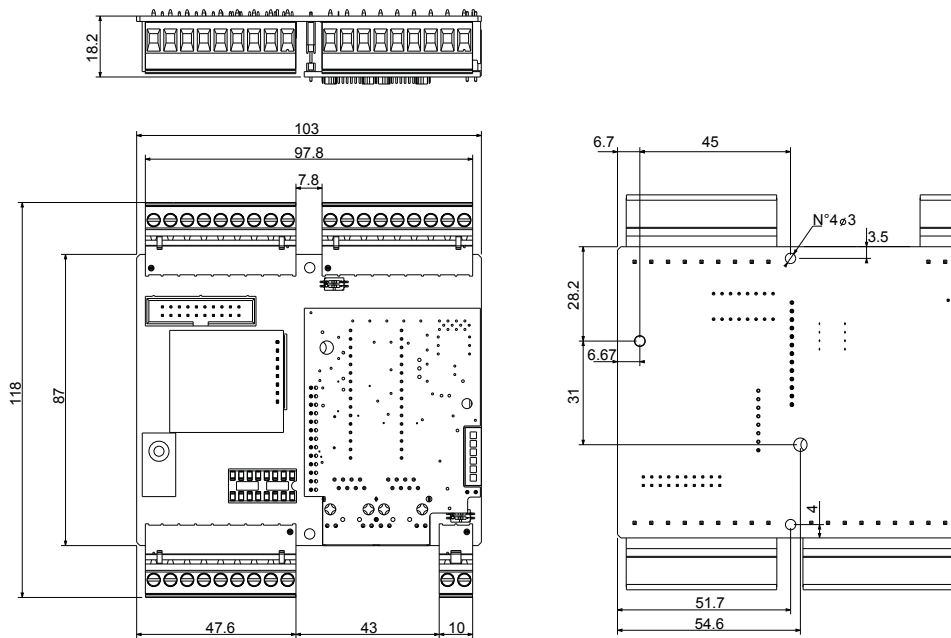

XSPEED TOOL | TOOL FOR FILTER CONFIGURATION**XSPEED TOOL**

Main features

Technical features

Time and frequency domain signal analysis.

Data reception at very high speed (up to 4.800 readings per second).

Automatic data acquisition based on time or weight thresholds.

Real time signal processing.

Application of filters of your choice, fully configurable, to remove vibrations, oscillations, peaks etc., making the weight stable and the scale reactive and performing.

Calibration of the instrument, which includes:

- Calibration using sample weights, with the possibility to linearize the system up to 8 points.
- Theoretical calibration, with the insertion of the data of the system to be created (load cells, dead load etc.).

Archive of weights and configured filters.

Filters

Coarse filter for the removal of signal background noise and weight stabilization.

Fine filter to increase the reading accuracy.

Selective filter to isolate and eliminate noise with precise frequencies.

Minimum requirements

Operating System: Windows 10

Processor: 1.6 Ghz

Ram: 4 Gb

Free hard disk space: 250 Mb

Version codes

		Description	Code
PC SOFTWARES		"XSPEED" PC software with oscilloscope function for system diagnostics and weighing filter optimization.	XSPEED

DINI AR GEO
XSPEED TOOL

Analysis

Check

Scale

Test

Settings

Device DGT4X

S.N. 0000000000

Release 05.02.00.003

TARE
kg

0 kg

GROSS
kg

Max. 10.000 kg d 0,001 kg

Check
 Raw data
 Overlap
 Hz spectrum

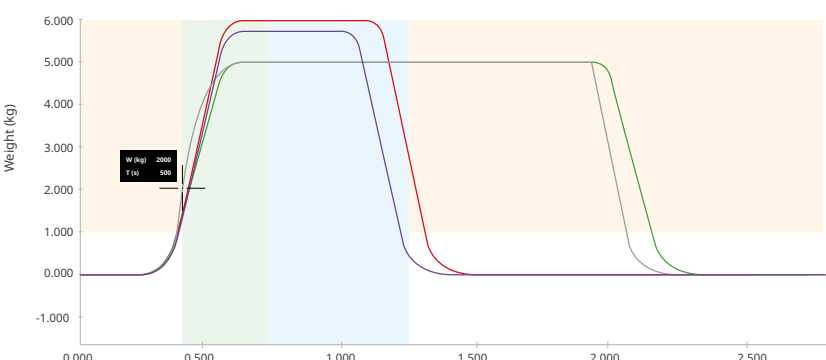

Weighs (kg)		Filter
1	Coarse 97 % Fine 50 % Selective 1 50 Hz Selective 2 100 Hz	X
2	Coarse 95 % Fine 40 % Selective 1 20 Hz Selective 2 10 Hz	X
3	Coarse 97 % Fine 50 % Selective 1 50 Hz Selective 2 100 Hz	X
4	Coarse 97 % Fine 50 % Selective 1 50 Hz Selective 2 100 Hz	X

Clear all

Expand

Narrow

Move

Setting time (s) 0,300

Measuring time (s) 0,500

Threshold (s) 1000

Correction (kg) 0,0000

Data acquisition

Triggers

Start 10 kg Stop 5 kg Start

Filters

Rate 2600 Hz

Coarse

94 %

It filters the belt vibration. Suggested from 94%.

Fine

50 %

It flats the wave. Suggested from 50%.

Selective 1

50 Hz

It removes a noise with a certain frequency

Selective 2

100 Hz

It removes a noise with a certain frequency

Send Receive



SAFETY & CONTROL WEIGHT TRANSMITTERS

“

These transmitters are the most convenient and cost-effective solution to create weight control and monitoring applications in industrial processes.

They are used to weigh silos, hoppers, roller conveyors and low-speed belts.

”

SAFETY & CONTROL WEIGHT TRANSMITTERS

Comparative table

		DGT1S PLUS	DGT1S	DGT1	DGT4	DGT1P	DGTP	DGTQ	DGT20	DGT20I
Mounting type		DIN Rail				Panel			Wall / Table	
Case		ABS	ABS	ABS	ABS	Aluminium	ABS	ABS	Stainless/ Painted steel	Stainless steel
Number of scales / channels		1	1	1	Up to 4	1	1	1	1	1
Conversion rate		Up to 400 Hz	Up to 400 Hz	Up to 400 Hz	Up to 400 Hz	Up to 400 Hz	Up to 400 Hz	Up to 400 Hz	Up to 400 Hz	Up to 400 Hz
Web server		•			•				•	
Integrated fieldbus		•			•		•	•	•	•
Modbus RTU		•	•	•	•	•	•	•	•	•
RS485		•	•	•	•	•	•	•	•	•
RS232		•	•	•	•		•	•	•	•
Digital I/O		•	•	•	•	•	•	•	•	•
Analog Output		•	•	•	•	•	•	•	•	•
Electric approvals	UL Listed	Upon request	Upon request		Upon request					
	OIML R61 MID	•	•	•	•	•	•	•	•	•
Metrological approvals	OIML R51	•	•	•	•	•	•	•	•	•
	OIML R76	•	•	•	•	•	•	•	•	•
	EU Type Examination certificate	•	•	•	•	•	•	•	•	•

DGT1S PLUS | 1 CHANNEL

WITH INTEGRATED FIELDBUS & WEB SERVER



LOAD CELL
FAILURE ALARM



OIML
APPROVED



USB
PORT



WEB
SERVER



Main features

Technical features			
Number of scales / channels	1		
Calibration	Electronic (Theoretical)	Real calibration with sample weights	Via Web server
Conversion rate	Up to 400 Hz		
Maximum display digits	0...800.000		
Maximum load cell number	Up to 16 x 350 Ω		
Minimum sensitivity	High resolution	0,01 μV/d	
	Legal for trade	0,3 μV/e	
Legal for trade number of intervals	Up to 10.000e or multirange 2 x 3.000e		
Load cell excitation voltage	5 V		
Communication ports	See version table		
Communication protocols	Modbus RTU, ASCII or fieldbus		
Web server	Included in fieldbus version, see version table		
Communication rate	Via serial port	Via Fieldbus	
	Up to 325 Hz	Up to 16 Hz	
Configuration PC utility	DiniTools		
Display	Red LED 8 mm, 6 digits		
Keyboard	Mechanical, 5 keys		
Case	ABS		
Power supply	12÷24 Vdc, 5 W		
Operating temperature range	Internal Use	OIML approved	Humidity
	-20 °C / +60 °C	-10 °C / +40 °C	85 %

Approvals	Type	Description
UL Listed	Electric	Upon request
2014/30/EU EMC	Electric	EN 61000-6-2 : 2005
		EN 61000-6-4 : 2007+A1 : 2011
		EN 61326-1 : 2013 EN 61326-1 : 2013 EN 55011 : 2009+A1 : 2010 EN 55011 : 2009+A1 : 2010
2014/35/EU LVD	Electric	EN 61010-1 : 2010
2011/65/EU (RoHS)	Electric	EN 50581 : 2012
OIML R61 - MID	Metrological	AWI - Automatic filling machine
OIML R51 - MID	Metrological	AWI - Checkweighers
OIML R76	Metrological	NAWI - Weight transmitter
EU Type Examination Certificate (2014/31/EU)	Metrological	NAWI - Weight transmitter

Analog output	
Settings	0÷5 Vdc, 0÷10 Vdc, 0÷20 mA, 4÷20 mA
Resolution	16 bit
Communication rate	0,1 s
Opto-isolated as standard	Yes

Digital inputs / outputs	V	I
2 Digital inputs	5 ÷ 48 Vdc	-
2 Digital outputs	48 Vdc	500 mA
Opto-isolated as standard	Yes	

Version codes

Fieldbus	Analog output	Modbus RTU	RS485	2 IN / 2 OUT	USB	Web server	Code	
		•	•	•			DGT1SP	
	•	•	•	•			DGT1SP-AN	
PROFINET				•	•	•	DGT1SP-PRONET	
EtherNet/IP				•	•	•	DGT1SP-ETHIP	
Modbus TCP/IP				•	•	•	DGT1SP-MODTCP	
EtherCAT				•	•		DGT1SP-ETHCAT	
Profibus				•	•		DGT1SP-PB	
CANopen				•	•		DGT1SP-CANOP	
DeviceNet				•	•		DGT1SP-DEVNET	

Main options and accessories (for a complete list visit www.diniargeo.com)

	Description	Code	
POWER SUPPLY	 12 Vdc power supply unit for DIN rail mounting. 110/240 Vac input. CE and UL certified. Not compatible with BOX2121S.	MDR2012	

Technical drawing (mm)

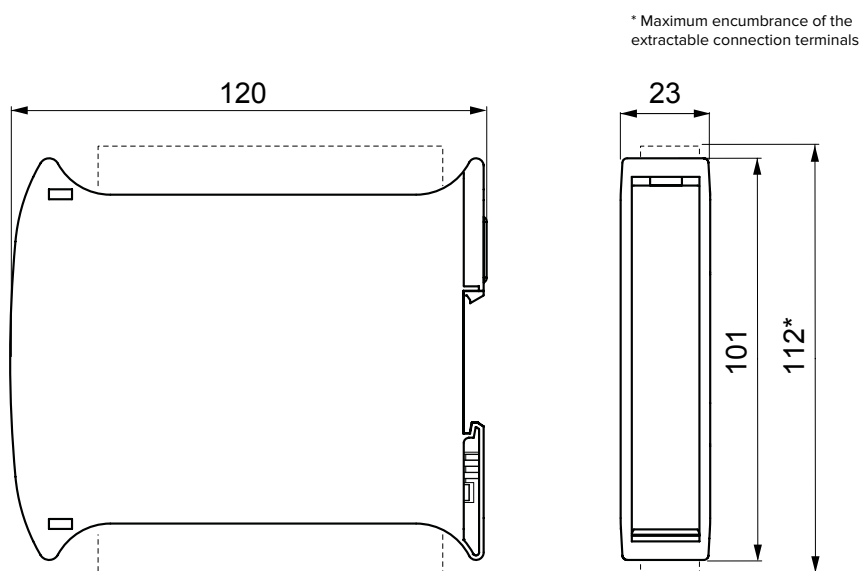

DGT1S | 1 CHANNELOIML
APPROVED

Main features

Technical features			
Number of scales / channels		1	
Calibration		Electronic (Theoretical)	Real calibration with sample weights
Conversion rate		Up to 400 Hz	
Maximum display digits		0..800.000	
Maximum load cell number		Up to 8 x 350 Ω	
Minimum sensitivity	High resolution	0,01 μV/d	
	Legal for trade	0,3 μV/e	
Legal for trade number of intervals		Up to 10.000e or multirange 2 x 3.000e	
Load cell excitation voltage		5 V	
Communication ports		See version table	
Communication protocols		Modbus RTU, ASCII or fieldbus	
Communication rate		Via serial port	Via Fieldbus
		Up to 325 Hz	Up to 16 Hz
Configuration PC utility		DiniTools	
Display		Red LED 8 mm, 6 digits	
Keyboard		Mechanical, 5 keys	
Case		ABS	
Power supply		12÷24 Vdc, 5 W	
Operating temperature range		Internal Use	OIML approved
		-20 °C / +60 °C	-10 °C / +40 °C
			Humidity
			85 %

Approvals	Type	Description
UL Listed	Electric	Upon request
2014/30/EU EMC	Electric	EN 61000-6-2 : 2005
		EN 61000-6-4 : 2007+A1 : 2011
		EN 61326-1 : 2013 EN 61326-1 : 2013
		EN 55011 : 2009+A1 : 2010 EN 55011 : 2009+A1 : 2010
2014/35/EU LVD	Electric	EN 61010-1 : 2010
2011/65/EU (RoHS)	Electric	EN 50581 : 2012
OIML R61 - MID	Metrological	AWI - Automatic filling machine
OIML R51 - MID	Metrological	AWI - Checkweighers
OIML R76	Metrological	NAWI - Weight transmitter
EU Type Examination Certificate (2014/31/EU)	Metrological	NAWI - Weight transmitter









Analog output	
Settings	0÷5 Vdc, 0÷10 Vdc, 0÷20 mA, 4÷20 mA
Resolution	16 bit
Communication rate	0,1 s
Opto-isolated as standard	Yes

Digital inputs / outputs	V	I
2 Digital inputs	12÷24 Vdc	5÷20 mA
2 Digital outputs	48 Vac 60 Vdc	150 mA
Opto-isolated as standard	Yes	

Version codes

Modbus RTU	RS485	RS232	2 IN / 2 OUT	Analog output	Code	
•	•	•	•		DGT1S	
•	•	•	•	•	DGT1SAN	

Main options and accessories (for a complete list visit www.diniargeo.com)

	Description	Code	
POWER SUPPLY	 12 Vdc power supply unit for DIN rail mounting. 110/240 Vac input. CE and UL certified. Not compatible with BOX2121S.	MDR2012	
WIFI	 Serial to WiFi compact converter for DIN rail mounting.	WIFIT1S-1	
ETHERCAT	 RS485 to EtherCAT interface, for DIN rail mounting. With UL marked PCB, terminal block, plastic box and labels (if applicable).	ETHERCAT1S	
ETHERNET/IP	 RS485 to Ethernet/IP interface, for DIN rail mounting. With UL marked PCB, terminal block, plastic box and labels (if applicable).	ETHERNETIP1S	
CANOPEN	 RS485 to CANopen interface, for DIN rail mounting. With UL marked PCB, terminal block, plastic box and labels (if applicable).	CANOPEN1S	
DEVICENET	 RS485 to DeviceNet interface, for DIN rail mounting. With UL marked PCB, terminal block, plastic box and labels (if applicable).	DEVICENET1S	
PROFIBUS	 RS485 to Profibus compact interface, for DIN rail mounting. With UL marked PCB, terminal block, plastic box and labels (if applicable).	PROFIBUS1S	
PROFINET	 RS485 to PROFINET interface, for DIN rail mounting. With UL marked PCB, terminal block, plastic box and labels (if applicable).	PROFINET1S	

Technical drawing (mm)

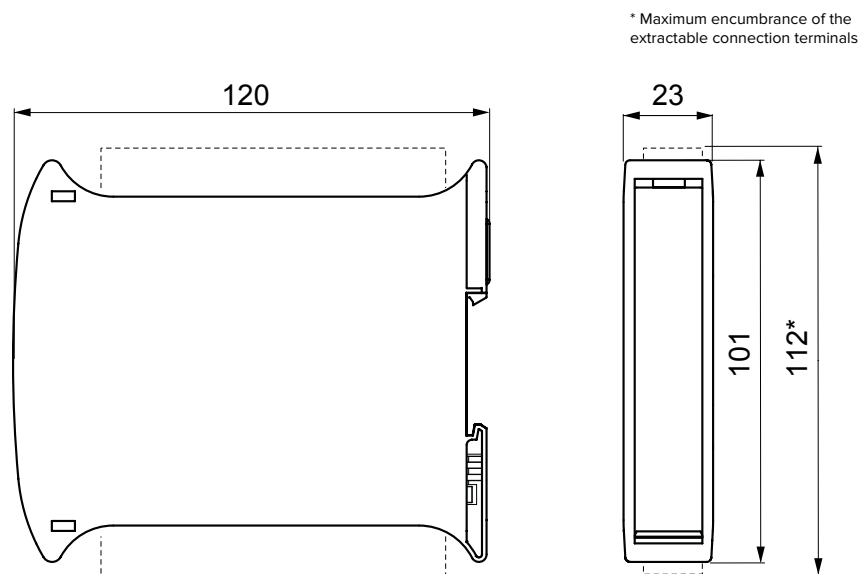

DGT1 | 1 CHANNELOIML
APPROVED

Main features

Technical features			
Number of scales / channels		1	
Calibration		Electronic (Theoretical)	Real calibration with sample weights
Conversion rate		Up to 400 Hz	
Maximum display digits		0...800.000	
Maximum load cell number		Up to 8 x 350 Ω	
Minimum sensitivity	High resolution	0,01 μ V/d	
	Legal for trade	0,3 μ V/e	
Legal for trade number of intervals		Up to 10.000e or multirange 2 x 3.000e	
Load cell excitation voltage		5 V	
Communication ports		See version table	
Communication protocols		Modbus RTU, ASCII	
Communication rate		Up to 325 Hz	
Configuration PC utility		DiniTools	
Display		Red LED 8 mm, 6 digits	
Keyboard		Waterproof mechanical, 5 keys	
Case		ABS	
Power supply		12÷24 Vdc, 5 W	
Operating temperature range		Internal Use	OIML approved
		-20 °C / +60 °C	-10 °C / +40 °C
			Humidity
			85 %

Approvals	Type	Description
2014/30/EU EMC	Electric	EN 61000-6-2 : 2005
		EN 61000-6-4 : 2007+A1 : 2011
		EN 61326-1 : 2013 EN 61326-1 : 2013
		EN 55011 : 2009+A1 : 2010 EN 55011 : 2009+A1 : 2010
2014/35/EU LVD	Electric	EN 61010-1 : 2010
2011/65/EU (RoHS)	Electric	EN 50581 : 2012
OIML R61 - MID	Metrological	AWI - Automatic filling machine
OIML R51 - MID	Metrological	AWI - Checkweighers
OIML R76	Metrological	NAWI - Weight transmitter
EU Type Examination Certificate (2014/31/EU)	Metrological	NAWI - Weight transmitter





Analog output	
Settings	0÷5 Vdc, 0÷10 Vdc, 0÷20 mA, 4÷20 mA
Resolution	16 bit
Communication rate	0,1 s
Opto-isolated as standard	Yes

Digital inputs / outputs	V	I
2 Digital inputs	12÷24 Vdc	5÷20 mA
2 Digital outputs	48 Vac 60 Vdc	150 mA
Opto-isolated as standard	Yes	

Version codes

Analog output	Modbus RTU	RS485	RS232	2 IN / 2 OUT	Code	
	•	•	•		DGT1	
	•	•	•	•	DGT1IO	
•	•	•	•		DGT1AN	

Main options and accessories (for a complete list visit www.diniargeo.com)

	Type	Description	Code	
SERIAL CONVERTERS	 Modbus TCP/IP	RS232 / RS485 to Ethernet converter.	SETHDIN-1	
	 Profibus DP	RS232 / RS485 to Profibus converter.	PROFI232-1	
POWER SUPPLY		Description 12 Vdc power supply unit for DIN rail mounting. 110/240 Vac input. CE and UL certified. Not compatible with BOX2121S.	Code MDR2012	
		Description ABS wall IP65 box with transparent door for installation 1 DGT1 + 1 Serial converter. Dimensions 210x210x100 mm, equipped with 2 cable glands. Not compatible with MDR2012.	Code BOX2121S	

Technical drawing (mm)

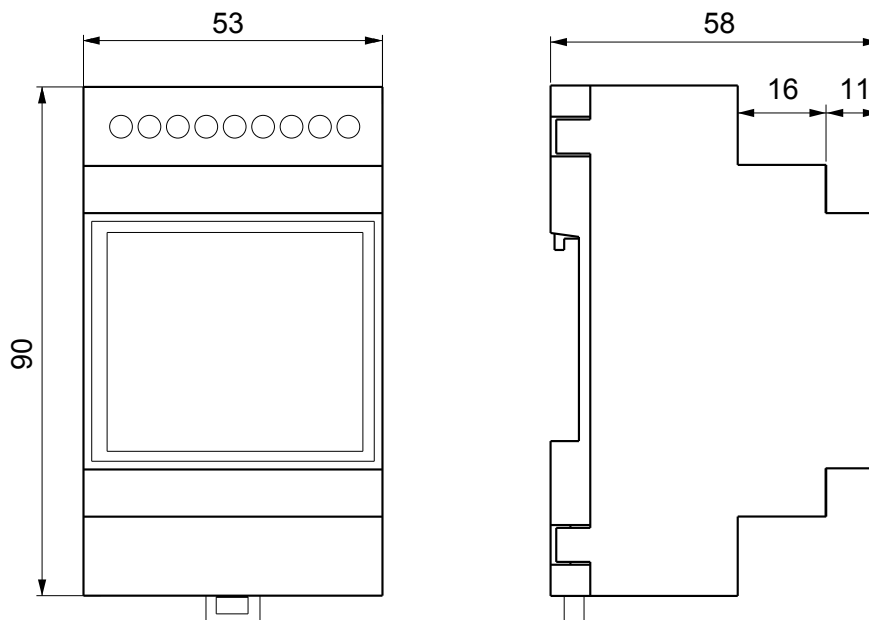

DGT4 | 4 CHANNELS

WITH INTEGRATED FIELDBUS & WEB SERVER



Main features

Technical features			
Number of scales / channels		Up to 4	
Calibration		Electronic (Theoretical)	Real calibration with sample weights
Conversion rate		Up to 400 Hz	
Maximum display digits		0..800.000	
Maximum load cell number		Up to 8 x 350 Ω	
Minimum sensitivity	High resolution	0,01 μV/d	
	Legal for trade	0,3 μV/e	
Legal for trade number of intervals		Up to 10.000e or multirange 2 x 3.000e	
Load cell excitation voltage		5 V	
Communication ports		See version table	
Communication protocols		Modbus RTU, ASCII or fieldbus	
Web server		Included in fieldbus version, see version table	
Communication rate	Via serial port		Via Fieldbus
	Up to 325 Hz		Up to 16 Hz
Configuration PC utility		DiniTools	
Display		Red LED 13 mm, 6 digits	
Keyboard		Waterproof mechanical, 5 keys	
Case		ABS	
Power supply		12÷24 Vdc, 5 W	
Operating temperature range	Internal Use	OIML approved	Humidity
	-20 °C / +60 °C	-10 °C / +40 °C	85 %

Approvals	Type	Description
UL Listed	Electric	Upon request
2014/30/EU EMC	Electric	EN 61000-6-2 : 2005
		EN 61000-6-4 : 2007+A1 : 2011
		EN 61326-1 : 2013 EN 61326-1 : 2013
		EN 55011 : 2009+A1 : 2010 EN 55011 : 2009+A1 : 2010
2014/35/EU LVD	Electric	EN 61010-1 : 2010
2011/65/EU (RoHS)	Electric	EN 50581 : 2012
OIML R61 - MID	Metrological	AWI - Automatic filling machine
OIML R51 - MID	Metrological	AWI - Checkweighers
OIML R76	Metrological	NAWI - Weight transmitter
EU Type Examination Certificate (2014/31/EU)	Metrological	NAWI - Weight transmitter



Analog output	
Settings	0÷5 Vdc, 0÷10 Vdc, 0÷20 mA, 4÷20 mA
Resolution	16 bit
Communication rate	0,1 s
Opto-isolated as standard	Yes

Digital inputs / outputs	V	I
2 Digital inputs	12÷24 Vdc	5÷20 mA
2 Digital outputs	48 Vac 60 Vdc	150 mA
Opto-isolated as standard	Yes	

Version codes

Fieldbus	Analog output	Modbus RTU	RS485	RS232	2 IN / 2 OUT	Web server	Code	
		•	•	•	•		DGT4	
	•	•	•	•	•		DGT4AN	
PROFINET				•	•	•	DGT4PRONET	
EtherNet/IP				•	•	•	DGT4ETHIP	
Modbus TCP/IP				•	•	•	DGT4MODTCP	
EtherCAT				•	•		DGT4ETHCAT	
Profibus				•	•		DGT4PB-1	
CANopen				•	•		DGT4CANOP	
DeviceNet				•	•		DGT4DEVNET	

Main options and accessories (for a complete list visit www.diniargeo.com)

	Description	Code	
POWER SUPPLY	 12 Vdc power supply unit for DIN rail mounting. 110/240 Vac input. CE and UL certified. Not compatible with BOX2121S.	MDR2012	
INSTALLATION BOX	 ABS wall IP65 box with transparent door for installation 1 DGT1 + 1 Serial converter. Dimensions 210x210x100 mm, equipped with 2 cable glands. Not compatible with MDR2012.	BOX2121S	

Technical drawing (mm)

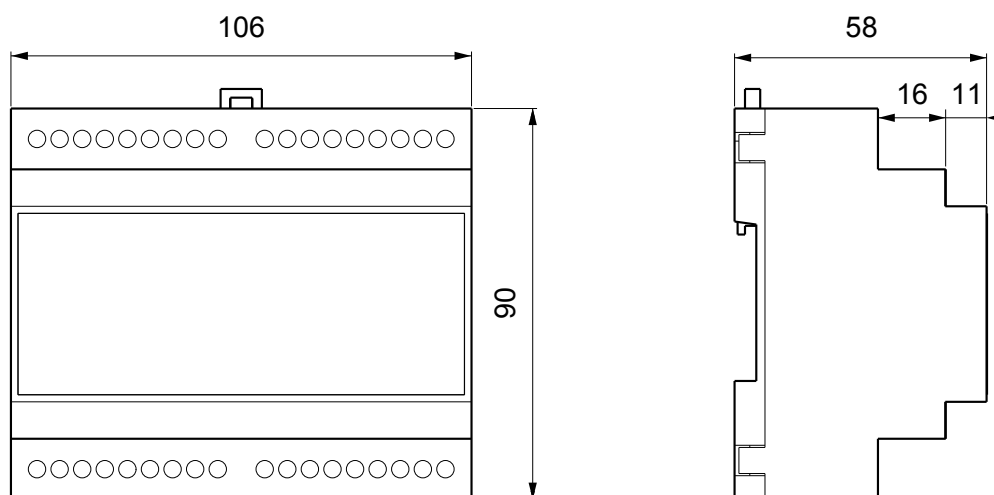

DGT1P | 1 CHANNELOIML
APPROVEDFRONT
PROTECTION

Main features

Technical features			
Number of scales / channels		1	
Calibration		Electronic (Theoretical)	Real calibration with sample weights
Conversion rate		Up to 400 Hz	
Maximum display digits		0...800.000	
Maximum load cell number		Up to 16 x 350 Ω	
Minimum sensitivity	High resolution	0,01 μV/d	
	Legal for trade	0,3 μV/e	
Legal for trade number of intervals		Up to 10.000e or multirange 2 x 3.000e	
Load cell excitation voltage		5 V	
Communication ports		See version table	
Communication protocols		Modbus RTU, ASCII	
Communication rate		Up to 325 Hz	
Configuration PC utility		DiniTools	
Display		Red LED 14,2 mm, 6 digits	
Keyboard		Waterproof mechanical, 5 keys	
Case		Aluminium	
Power supply		12÷24 Vdc, 5 W	
Operating temperature range		Internal Use	OIML approved
		-20 °C / +60 °C	-10 °C / +40 °C
			Humidity
			85 %

Approvals	Type	Description
2014/30/EU EMC	Electric	EN 61000-6-2 : 2005
		EN 61000-6-4 : 2007+A1 : 2011
		EN 61326-1 : 2013 EN 61326-1 : 2013
		EN 55011 : 2009+A1 : 2010 EN 55011 : 2009+A1 : 2010
2014/35/EU LVD	Electric	EN 61010-1 : 2010
2011/65/EU (RoHS)	Electric	EN 50581 : 2012
OIML R61 - MID	Metrological	AWI - Automatic filling machine
OIML R51 - MID	Metrological	AWI - Checkweighers
OIML R76	Metrological	NAWI - Weight transmitter
EU Type Examination Certificate (2014/31/EU)	Metrological	NAWI - Weight transmitter

Analog output	
Settings	0÷5 Vdc, 0÷10 Vdc, 0÷20 mA, 4÷20 mA
Resolution	16 bit
Communication rate	0,1 s
Opto-isolated as standard	Yes

Digital inputs / outputs	V	I
2 Digital inputs	12÷24 Vdc	5÷20 mA
2 Digital outputs	48 Vac 60 Vdc	500 mA
Opto-isolated as standard	Yes	

Version codes

Analog output	Modbus RTU	RS485	2 IN / 2 OUT	Code	
	•	•	•	DGT1P	
•	•	•	•	DGT1PAN	

Main options and accessories *(for a complete list visit www.diniargeo.com)*

	Description	Code	
POWER SUPPLY	 12 Vdc power supply unit for DIN rail mounting. 110/240 Vac input. CE and UL certified. Not compatible with BOX2121S.	MDR2012	

	Description	Code	
OUTPUT	 Set of 4 optoisolated outputs (mounting and cable gland excluded).	C4OUT	

Technical drawing (mm)

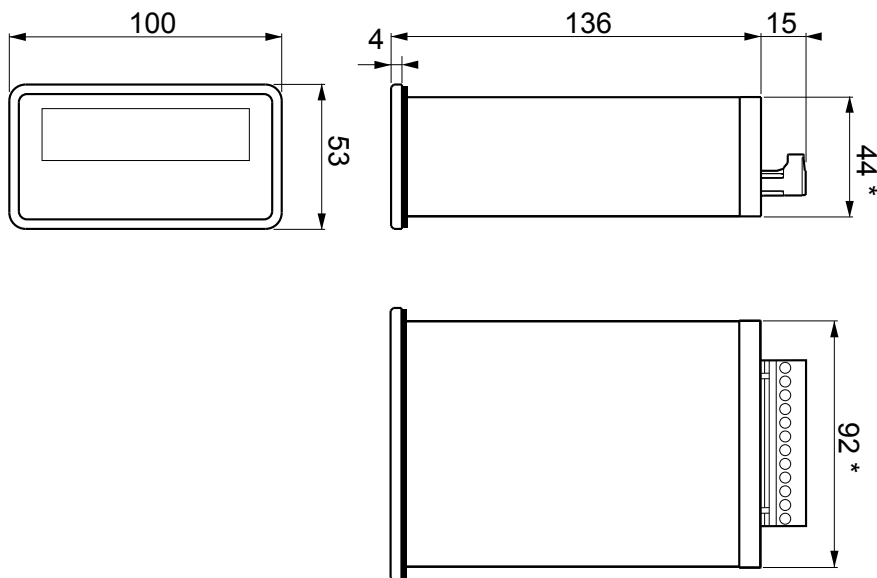

* Panel cutout (lxh) - 92 x 44 mm

DGTP | 1 CHANNEL

WITH INTEGRATED PROFIBUS

OIML
APPROVED

Main features

Technical features			
Number of scales / channels		1 (up to 4 upon request)	
Calibration		Electronic (Theoretical)	Real calibration with sample weights
Conversion rate		Up to 400 Hz	
Maximum display digits		0...800.000	
Maximum load cell number		Up to 16 x 350 Ω	
Minimum sensitivity	High resolution	0,01 μV/d	
	Legal for trade	0,3 μV/e	
Legal for trade number of intervals		Up to 10.000e or multirange 2 x 3.000e	
Load cell excitation voltage		5 V	
Communication ports		See version table	
Communication protocols		Modbus RTU, ASCII	
Communication rate	Via serial port	Via Fieldbus	
	Up to 325 Hz	Up to 16 Hz	
Configuration PC utility		DiniTools	
Display		Red LED 20 mm, 6 digits	
Keyboard		Waterproof mechanical, 5 keys	
Case		ABS	
Power supply		12÷24 Vdc, 5 W	
Operating temperature range	Internal Use	OIML approved	Humidity
	-20 °C / +60 °C	-10 °C / +40 °C	85 %

Approvals	Type	Description
2014/30/EU EMC	Electric	EN 61000-6-2 : 2005
		EN 61000-6-4 : 2007+A1 : 2011
		EN 61326-1 : 2013 EN 61326-1 : 2013
		EN 55011 : 2009+A1 : 2010 EN 55011 : 2009+A1 : 2010
2014/35/EU LVD	Electric	EN 61010-1 : 2010
2011/65/EU (RoHS)	Electric	EN 50581 : 2012
OIML R61 - MID	Metrological	AWI - Automatic filling machine
OIML R51 - MID	Metrological	AWI - Checkweighers
OIML R76	Metrological	NAWI - Weight transmitter
EU Type Examination Certificate (2014/31/EU)	Metrological	NAWI - Weight transmitter

Analog output	
Settings	0÷5 Vdc, 0÷10 Vdc, 0÷20 mA, 4÷20 mA
Resolution	16 bit
Communication rate	0,1 s
Opto-isolated as standard	Yes

Digital inputs / outputs	V	I
2 Digital inputs	12÷24 Vdc	5÷20 mA
2 Digital outputs	48 Vac 60 Vdc	150 mA
Opto-isolated as standard	Yes	

Version codes

Fieldbus	Analog output	Modbus RTU	RS485	RS232	2 IN / 2 OUT	Code	
		•	•	•	•	DGTP	
	•	•	•	•	•	DGTPAN	
Profibus			•	•	•	DGTPPB-1	

Main options and accessories (for a complete list visit www.diniargeo.com)

	Description	Code	
POWER SUPPLY	 12 Vdc power supply unit for DIN rail mounting. 110/240 Vac input. CE and UL certified. Not compatible with BOX2121S.	MDR2012	

Technical drawing (mm)

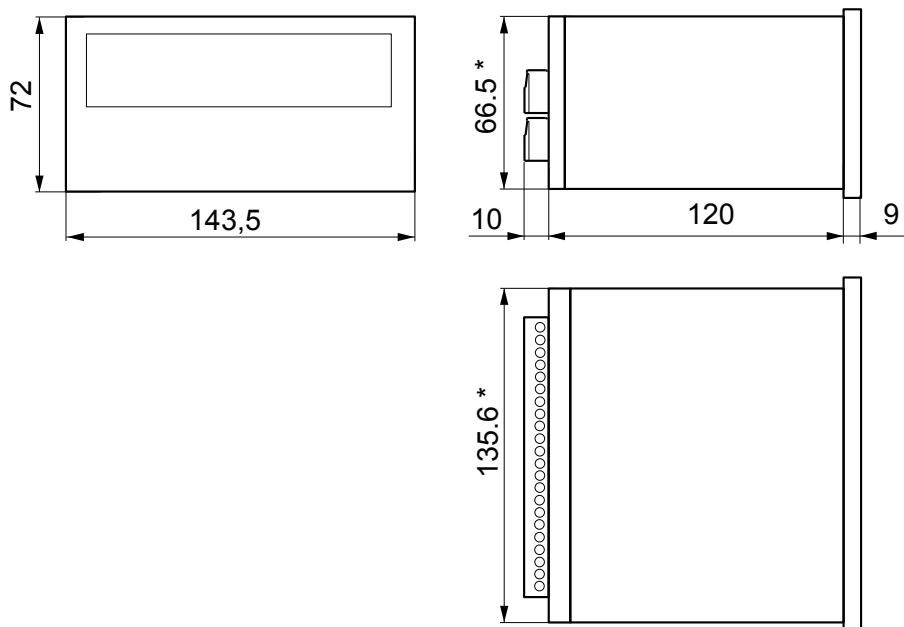

* Panel cutout (w x h) - 135,6 x 66,5 mm

DGTQ | 1 CHANNEL

WITH INTEGRATED PROFIBUS



Main features

Technical features			
Number of scales / channels		1 (up to 4 upon request)	
Calibration		Electronic (Theoretical)	Real calibration with sample weights
Conversion rate		Up to 400 Hz	
Maximum display digits		0...800.000	
Maximum load cell number		Up to 8 x 350 Ω	
Minimum sensitivity	High resolution	0,01 μ V/d	
	Legal for trade	0,3 μ V/e	
Legal for trade number of intervals		Up to 10.000e or multirange 2 x 3.000e	
Load cell excitation voltage		5 V	
Communication ports		See version table	
Communication protocols		Modbus RTU, ASCII	
Communication rate	Via serial port	Up to 325 Hz	Via Fieldbus
			Up to 16 Hz
Configuration PC utility		DiniTools	
Display		Red LED 8 mm, 6 digits	
Keyboard		Waterproof mechanical, 5 keys	
Case		ABS	
Power supply		12÷24 Vdc, 5 W	
Operating temperature range	Internal Use	-20 °C / +60 °C	
	OIML approved		-10 °C / +40 °C
	Humidity		85 %

Approvals	Type	Description
2014/30/EU EMC	Electric	EN 61000-6-2 : 2005
		EN 61000-6-4 : 2007+A1 : 2011
		EN 61326-1 : 2013 EN 61326-1 : 2013
		EN 55011 : 2009+A1 : 2010 EN 55011 : 2009+A1 : 2010
2014/35/EU LVD	Electric	EN 61010-1 : 2010
2011/65/EU (RoHS)	Electric	EN 50581 : 2012
OIML R61 - MID	Metrological	AWI - Automatic filling machine
OIML R51 - MID	Metrological	AWI - Checkweighers
OIML R76	Metrological	NAWI - Weight transmitter
EU Type Examination Certificate (2014/31/EU)	Metrological	NAWI - Weight transmitter



Analog output	
Settings	0÷5 Vdc, 0÷10 Vdc, 0÷20 mA, 4÷20 mA
Resolution	16 bit
Communication rate	0,1 s
Opto-isolated as standard	Yes

Digital inputs / outputs	V	I
2 Digital inputs	12÷24 Vdc	5÷20 mA
2 Digital outputs	48 Vac 60 Vdc	150 mA
Opto-isolated as standard	Yes	

Version codes

Fieldbus	Analog output	Modbus RTU	RS485	RS232	2 IN / 2 OUT	Code	
		•	•	•	•	DGTQ	
	•	•	•	•	•	DGTQAN	
Profibus			•	•	•	DGTQPB-1	

Main options and accessories *(for a complete list visit www.dinargeo.com)*

	Description	Code	
POWER SUPPLY	 12 Vdc power supply unit for DIN rail mounting. 110/240 Vac input. CE and UL certified. Not compatible with BOX2121S.	MDR2012	
OUTPUT	 Set of 4 optoisolated outputs (mounting and cable gland excluded).	C4OUT	

Technical drawing (mm)

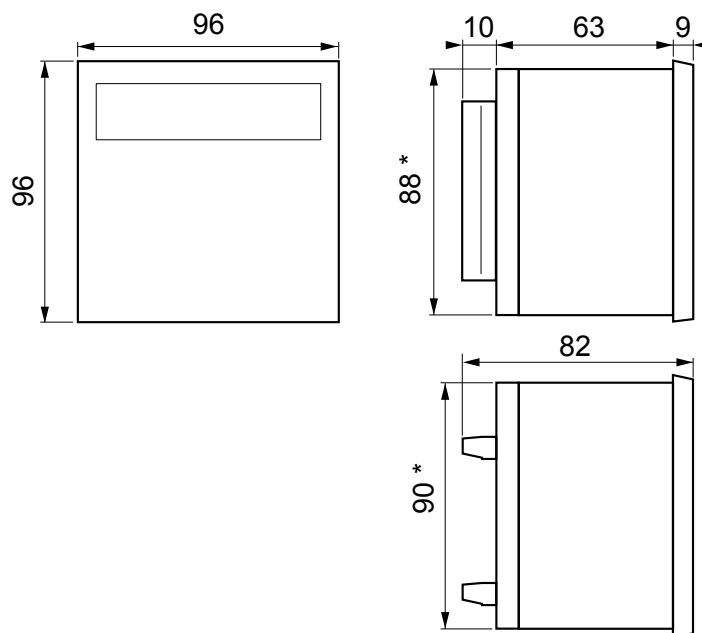

* Panel cutout (w x h) - 90 x 88,6 mm

DGT20 | 1 CHANNEL

WITH INTEGRATED FIELDBUS & WEB SERVER

WALL
BRACKET
INCLUDED

Main features

Technical features			
Number of scales / channels		1 (up to 4 upon request)	
Calibration		Electronic (Theoretical)	Real calibration with sample weights
Conversion rate		Up to 400 Hz	
Maximum display digits		0..800.000	
Maximum load cell number		Up to 8 x 350 Ω	
Minimum sensitivity	High resolution	0,01 μV/d	
	Legal for trade	0,3 μV/e	
Legal for trade number of intervals		Up to 10.000e or multirange 2 x 3.000e	
Load cell excitation voltage		5 V	
Communication ports		See version table	
Communication protocols		Modbus RTU, ASCII or fieldbus	
Communication rate		Via serial port	Via Fieldbus
		Up to 325 Hz	Up to 16 Hz
Web server		Included in fieldbus version, see version table	
Configuration PC utility		DiniTools	
Display		Red LED 6 20-mm digits and 6 LEDs to show active functions	
Keyboard		Waterproof mechanical, 5 keys	
Case		Aluminium panel, stainless steel enclosure. Wall bracket included.	
Power supply		12÷24 Vdc, 5 W. Power supply unit included.	
Operating temperature range		Internal Use	OIML approved
		-20 °C / +60 °C	-10 °C / +40 °C
		Humidity	
		85 %	

Approvals	Type	Description
2014/30/EU EMC	Electric	EN 61000-6-2 : 2005
		EN 61000-6-4 : 2007+A1 : 2011
		EN 61326-1 : 2013 EN 61326-1 : 2013
		EN 55011 : 2009+A1 : 2010 EN 55011 : 2009+A1 : 2010
2014/35/EU LVD	Electric	EN 61010-1 : 2010
2011/65/EU (RoHS)	Electric	EN 50581 : 2012
OIML R61 - MID	Metrological	AWI - Automatic filling machine
OIML R51 - MID	Metrological	AWI - Checkweighers
OIML R76	Metrological	NAWI - Weight transmitter
EU Type Examination Certificate (2014/31/EU)	Metrological	NAWI - Weight transmitter

Analog output	
Settings	0÷5 Vdc, 0÷10 Vdc, 0÷20 mA, 4÷20 mA
Resolution	16 bit
Communication rate	0,1 s
Opto-isolated as standard	Yes

Digital inputs / outputs	V	I
2 Digital inputs	12÷24 Vdc	5÷20 mA
2 Digital outputs	48 Vac 60 Vdc	150 mA
Opto-isolated as standard	Yes	

Version codes

Fieldbus	Analog output	Modbus RTU	RS485	RS232	2 IN / 2 OUT	Web server	Code	
		•	•	•	•		DGT20	
	•	•	•	•	•		DGT20AN	
PROFINET				•	•	•	DGT20PRONET	
EtherNet/IP				•	•	•	DGT20ETHIP	
Modbus TCP/IP				•	•	•	DGT20MODTCP	
EtherCAT				•	•		DGT20ETHCAT	
Profibus				•	•		DGT20PB-1	

Main options and accessories (for a complete list visit www.diniargeo.com)

	Description	Code	
SUPPORT BRACKETS	 Kit for panel installation.	DGTSTF	

Technical drawing (mm)

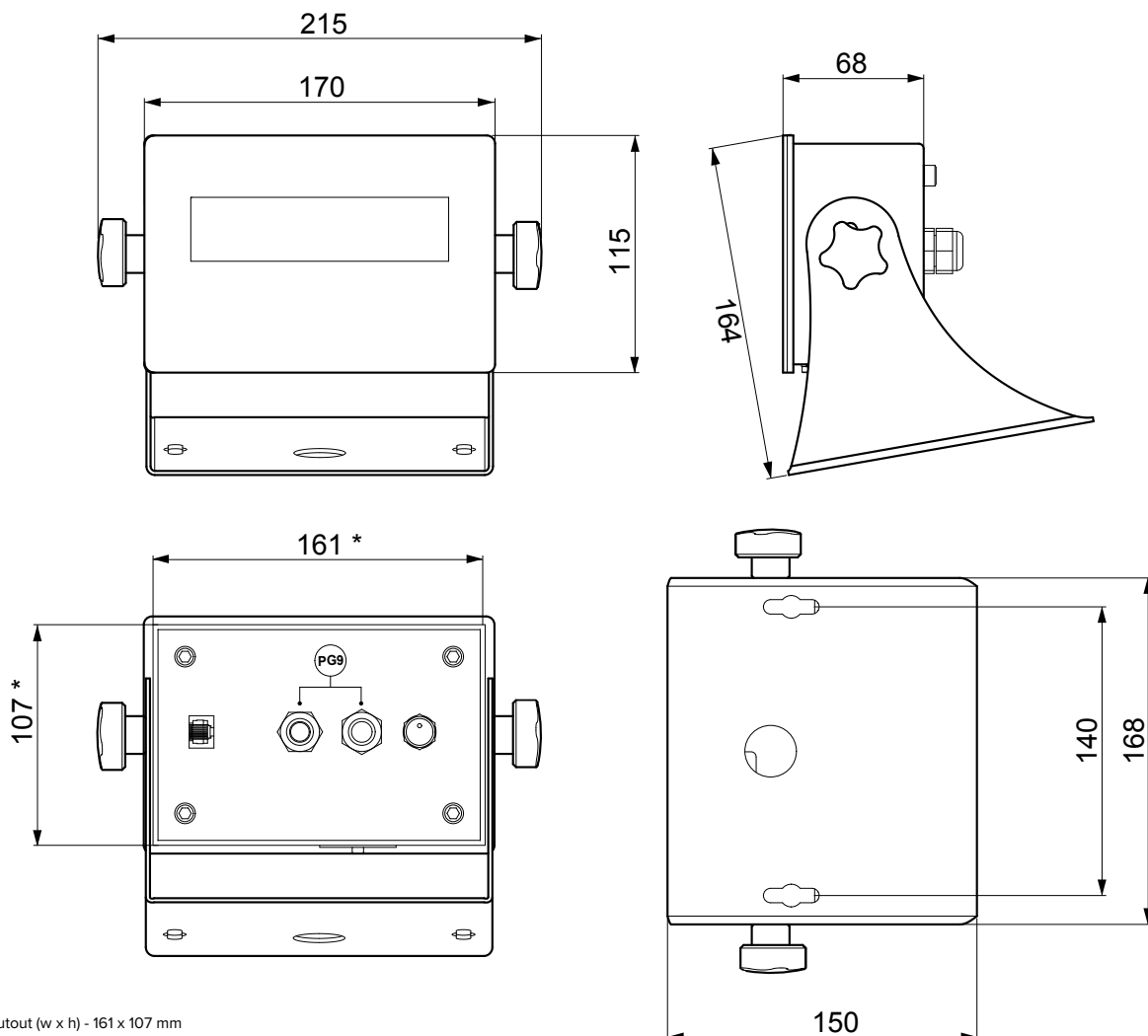

* Panel cutout (w x h) - 161 x 107 mm

DGT20I | 1 CHANNELOIML
APPROVEDIP
PROTECTIONUNIVERSAL
BRACKET230V
PLUG

Main features

Technical features		
Number of scales / channels	1 (up to 4 upon request)	
Calibration	Electronic (Theoretical)	Real calibration with sample weights
Conversion rate	Up to 400 Hz	
Maximum display digits	0..800.000	
Maximum load cell number	Up to 8 x 350 Ω	
Minimum sensitivity	High resolution	0,01 μV/d
	Legal for trade	0,3 μV/e
Legal for trade number of intervals	Up to 10.000e or multirange 2 x 3.000e	
Load cell excitation voltage	5 V	
Communication ports	See version table	
Communication protocols	Modbus RTU, ASCII or fieldbus	
Communication rate	Via serial port	Via Fieldbus
	Up to 325 Hz	Up to 16 Hz
Configuration PC utility	DiniTools	
Display	Red LED 6 20-mm digits and 6 LEDs to show the active functions	
Keyboard	Waterproof mechanical, 5 keys	
IP protection rating	IP68	
Case	Full stainless steel AISI 304 enclosure. Wall bracket included.	
Power supply	12÷24 Vdc, 5 W. Power supply unit included.	
Operating temperature range	Internal Use	OIML approved
	-20 °C / +60 °C	-10 °C / +40 °C

Approvals	Type	Description
2014/30/EU EMC	Electric	EN 61000-6-2 : 2005
		EN 61000-6-4 : 2007+A1 : 2011
		EN 61326-1 : 2013 EN 61326-1 : 2013
		EN 55011 : 2009+A1 : 2010 EN 55011 : 2009+A1 : 2010
2014/35/EU LVD	Electric	EN 61010-1 : 2010
2011/65/EU (RoHS)	Electric	EN 50581 : 2012
OIML R61 - MID	Metrological	AWI - Automatic filling machine
OIML R51 - MID	Metrological	AWI - Checkweighers
OIML R76	Metrological	NAWI - Weight transmitter
EU Type Examination Certificate (2014/31/EU)	Metrological	NAWI - Weight transmitter

Analog output	
Settings	0÷5 Vdc, 0÷10 Vdc, 0÷20 mA, 4÷20 mA
Resolution	16 bit
Communication rate	0,1 s
Opto-isolated as standard	Yes

Digital inputs / outputs	V	I
2 Digital inputs	12÷24 Vdc	5÷20 mA
2 Digital outputs	48 Vac 60 Vdc	150 mA
Opto-isolated as standard	Yes	

Version codes

Analog output	Modbus RTU	RS485	RS232	2 IN / 2 OUT	230V Plug	Code	
	•	•	•	•		DGT20I-1	
	•	•	•	•	•	DGT20IPW	
•	•	•	•	•		DGT20IAN-1	

Main options and accessories (for a complete list visit www.dinargeo.com)

	Description	Code	
SUPPORT BRACKETS	 Kit for panel installation.	DGT20ISTF	

Technical drawing (mm)

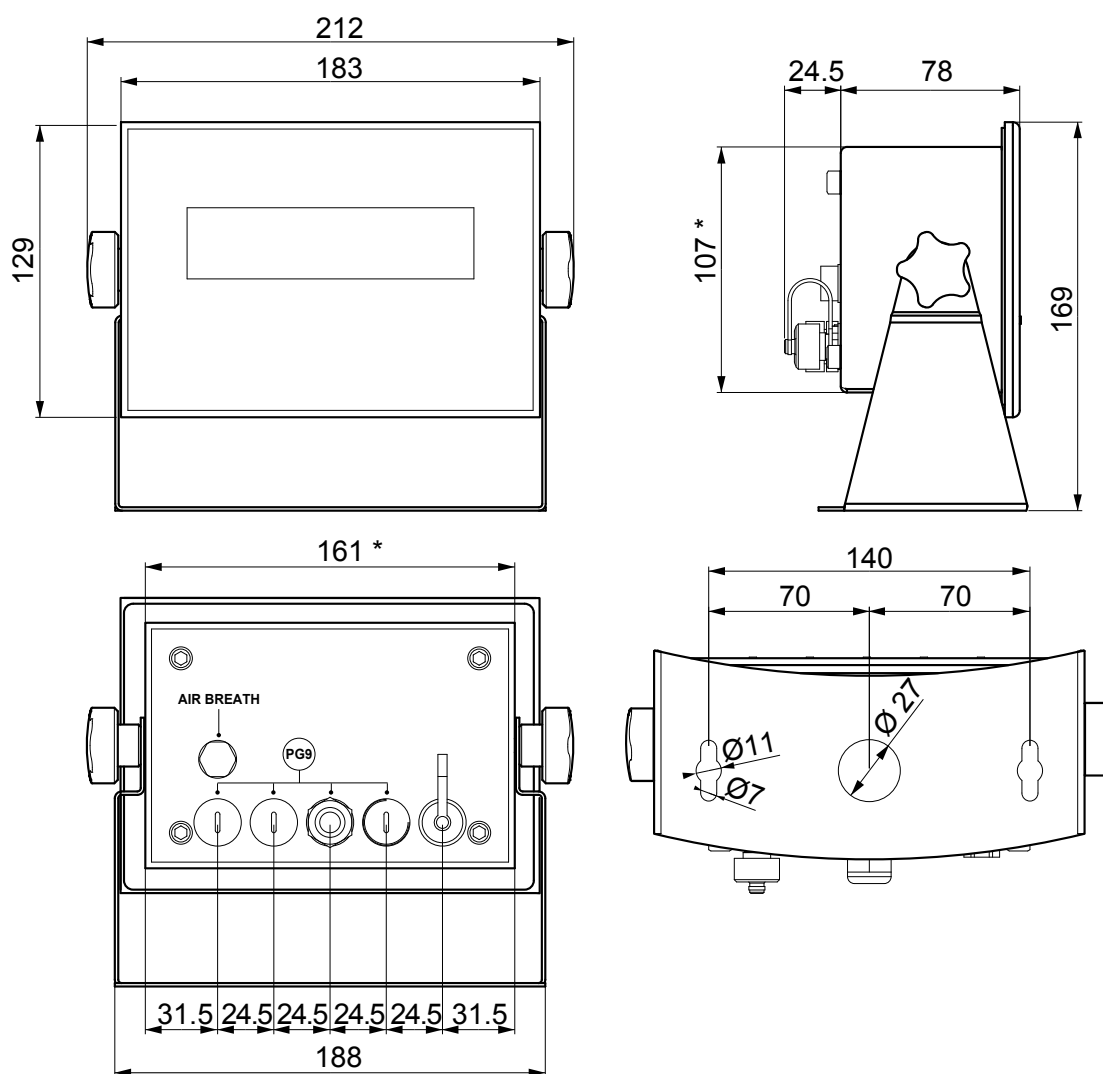

* Panel cutout (w x h) - 161 x 107 mm

DGT100 | 1 CHANNEL

Highlights:

- indicator / weight repeater with large display
- super-bright, high-intensity LEDs
- housing completely made of AISI 304 stainless steel with IP68 protection

OIML
APPROVED

Main features

Technical features			
Number of scales / channels		4	
Calibration		Electronic (Theoretical)	Real calibration with sample weights
Conversion rate		Up to 400 Hz	
Maximum display digits		0...800.000	
Maximum load cell number		Up to 8 x 350 Ω	
Minimum sensitivity	High resolution	0,01 μV/d	
	Legal for trade	0,3 μV/e	
Legal for trade number of intervals		Up to 10.000e or multirange 2 x 3.000e	
Load cell excitation voltage		5 V	
Communication ports		See version table	
Communication protocols		Modbus RTU, ASCII	
Communication rate		Up to 325 Hz	
Configuration PC utility		DiniTools	
Display		Red LED 100 mm, 6 characters	
Keyboard		Waterproof mechanical, 5 keys	
Case		Stainless steel	
Power supply		1110-240 Vac	
Operating temperature range	Internal Use	OIML approved	Humidity
	-20 °C / +60 °C	-10 °C / +40 °C	85 %

Approvals	Type	Description
OIML R61 - MID	Metrological	AWI - Automatic filling machine
OIML R51 - MID	Metrological	AWI - Checkweighers
OIML R76	Metrological	NAWI - Weight transmitter
EU Type Examination Certificate (2014/31/EU)	Metrological	NAWI - Weight transmitter
NMI S788	Metrological	Australian legal for trade certificate of approval





Analog output	
Settings	0÷5 Vdc, 0÷10 Vdc, 4÷20 mA
Resolution	16 bit
Communication rate	0,1 s
Opto-isolated as standard	Yes

Digital inputs / outputs	V	I
2 Digital inputs	12÷24 Vdc	5÷20 mA
2 Digital outputs	48 Vac 60 Vdc	150 mA
Opto-isolated as standard	Yes	

Version codes

Analog output	Modbus RTU	RS485	RS232	2 IN / 2 OUT	Code	
	•	•	•	•	DGT100BC-1	
•	•	•	•	•	DGT100AN-1	
	•	•	•	•	DGT100PB-1	
	•	•	•	•	DGT100R-1	

Main options and accessories (for a complete list visit www.diniargeo.com)

	Type	Description	Code	
SERIAL CONVERTERS	 Modbus TCP/IP	RS232 / RS485 to Ethernet converter.	SETHDIN-1	
	 Profibus DP	RS232 / RS485 to Profibus converter.	PROFI232-1	
POWER SUPPLY		Description 12 Vdc power supply unit for DIN rail mounting. 110/240 Vac input. CE and UL certified. Not compatible with BOX2121S.	MDR2012	
		Description ABS wall IP65 box with transparent door for installation 1 DGT1 + 1 Serial converter. Dimensions 210x210x100 mm, equipped with 2 cable glands. Not compatible with MDR2012.	BOX2121S	

Technical drawing (mm)

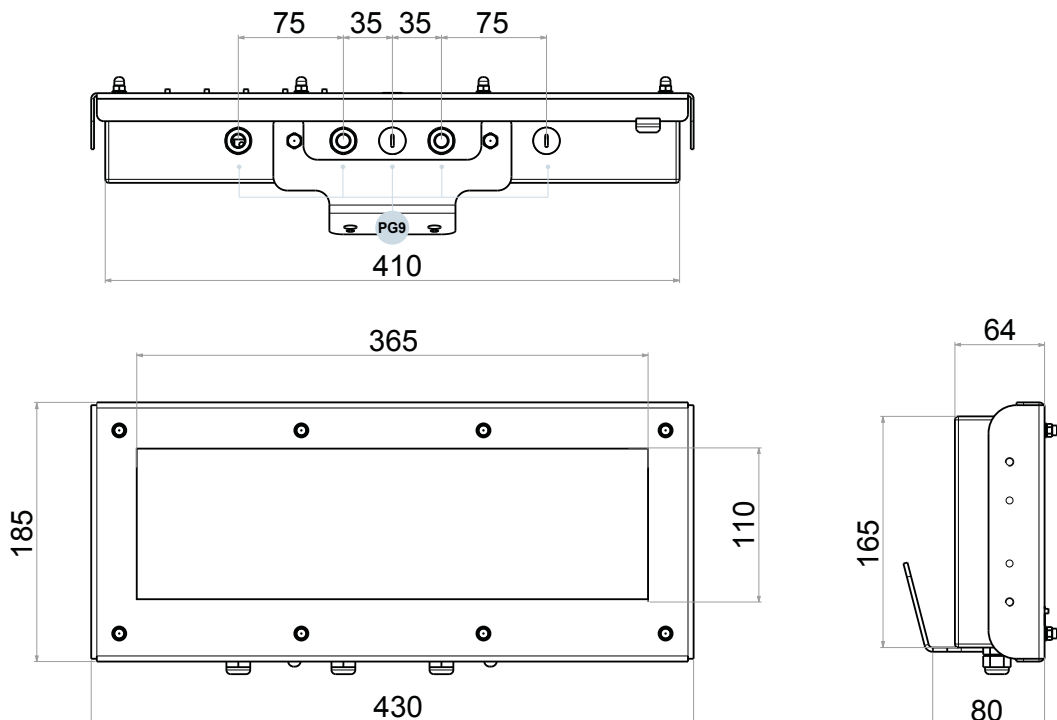

GENERAL SALES AND WARRANTY CONDITIONS

Sales prices are always net of VAT, to be paid by the buyer.

WARRANTY / TECHNICAL ASSISTANCE - INSTALLATION / RETURNED GOODS

The warranty period is 24 months from delivery, excluding the parts classified as expendable materials such as: mechanical print heads, batteries, mass storages (SD, USB, etc.), electric motors, and wheels. The warranty period for these expendable materials is 3 months.

The warranty refers to breakdowns resulting from any construction defect or material defect of the product supplied and covers the cost of labour and spare parts. The product must be returned to Dini Argeo headquarters in its original packaging with shipping paid by the sender.

If work is required at the place of use, the applicant will bear the technician's transfer expenses. Dini Argeo will bear the labour of the repair and the cost of any replaced parts.

The warranty does not apply to breakdowns due to improper use or non-observance of the operating instructions, electrical phenomenon, tampering, unauthorised attempted repair, connections to other equipment or removal of any product identification elements (serial number, label, etc.). This warranty does not provide for any compensation for damages, direct or indirect, incurred by the user due to complete or partial failure of instruments or systems sold, even during the warranty period. The warranty for the load cells excludes the damages caused by impacts and overloads (the overload is evident if the cell output signal measured, powered and without load, has an output voltage over 1 mV).

REPAIRS - RETURNED GOODS - RMA

Repairs at Dini Argeo premises are carried out at the current hourly rates and on the basis of the prices shown in the spare parts price list. If the repair price estimate is necessary before proceeding, the applicant must explicitly request it when ordering the repair of the goods. In this case the repair will be made once the price estimate filled in by the Dini Argeo technical assistance dept. has been accepted.

Technical assistance and/or installation at the customer's premises is carried out upon agreement with Dini Argeo technical and/or sales personnel and with written confirmation for acceptance of the conditions in force.

The repair of DINI ARGEO products must be requested by sending the proper RMA (Return Material Authorization) form. Once the form has been received the Technical Assistance Dept. will communicate the applicant the RMA number that is to be indicated on the documents of transport. To use this service, simply access the reserved area and fill in the on-line form in order to send the material for repair.

Returned products will only be accepted, if previously agreed upon and authorised by Dini Argeo's sales office.

TRANSPORT AND PACKAGING

Delivery is Ex Works. The transport risks, loss and/or damage of goods, are to be borne by the buyer even if the goods are delivered carriage free. Transportation by couriers affiliated with Dini Argeo is available.

The prices shown include also cardboard packaging when the goods fit in a carton with dimensions up to 680 x 520 x 320 mm. When the goods take up more space pallets are used.

MINIMUM INVOICING / PAYMENT / OTHER CONDITIONS

For orders whose total amounts are less than 50 Euro, prices are net of discounts.

Payment delays, collection fees, and interest arrears will be charged at the "prime rate" increased by 5 percentage points. Any claims or objections do not authorise the buyer to delay or suspend payments.

The sales prices are considered accepted by Dini Argeo only after written confirmation of the purchase order by Dini Argeo and except for what was sold.

Dini Argeo reserves the right of ownership on the delivered material until the customer has paid for the goods. Any disputes arising under or in connection with the supply of products shall be finally settled according to Italian law and the place of jurisdiction is Modena.

SELLING AND SUPPORTING PRODUCTS RESTRICTIONS

As countries and companies place restrictions on the locations they will do business with, it is critical you understand how these restrictions may apply to you, so you can maintain trade compliance.

Companies located in these countries cannot receive sales or support for Rice Lake's global brands products from our offices or through our authorized distributors; for the most up to date list of countries and regions that have restrictions, please visit the [General Sales and Warranty Conditions](#) page on the Dini Argeo website.

Dini Argeo dealer network:
over 3500 partners
in more than 85 countries across the world

“YOUR WORLDWIDE PARTNER
FOR WEIGHING”



A RICE LAKE WEIGHING SYSTEMS COMPANY

COMPANY HEADQUARTERS

Via Della Fisica, 20
41042 Spezzano di Fiorano Modena • Italy
Tel. +39.0536 843418

SERVICE ASSISTANCE

Via Dell'Elettronica, 15
41042 Spezzano di Fiorano Modena • Italy
Tel. +39.0536 921784

OTHER DINI ARGEO LOCATIONS

DINI ARGEO WEIGHING INSTRUMENTS Ltd
China

DINI ARGEO UK Ltd
United Kingdom

DINI ARGEO FRANCE sarl
France

DINI ARGEO GMBH
Germany

DINI ARGEO OCEANIA
Australia

WHY CHOOSE DINI ARGEO?



WORLDWIDE SERVICE AND SHIPPING

International group
with offices in America,
Europe, India, China,
Mexico and Oceania,
over 900 employees
and a network of
specialised partners
in 130 countries
worldwide.



FAST SHIPPING

Dini Argeo always
keeps complete
systems in stock that
can be shipped quickly.



MADE IN ITALY

Dini Argeo weighing
solutions are made in
Italy and guarantee
the highest quality
standards.

SALES SERVICE AND TECHNICAL ASSISTANCE

Mod **LCELL - CEN**

P/N 
LCELL - CEN

Sn 
NOSN

LCELL - CEN/NOSN

Rev. 01.01.2024